

T A B L E O F C O N T E N T S

INSTALLATION SECTION

PART	DESCRIPTION	PAGE
1	<u>PRE-INSTALLATION INFORMATION</u>	
1.1	<u>SITE REQUIREMENTS.....</u>	<u>1.1</u>
1.2	<u>GROUNDING CONDITIONS.....</u>	<u>1.2</u>
1.3	<u>POWER CONDITIONS.....</u>	<u>1.4</u>
1.4	<u>UNPACKING AND INSPECTION.....</u>	<u>1.4</u>
2	<u>INSTALLING CABINETS</u>	
2.1	<u>SYSTEM INSTALLATION PROCEDURE.....</u>	<u>2.1</u>
2.2	<u>SELECTING INSTALLATION METHOD.....</u>	<u>2.1</u>
2.3	<u>INSTALLING IN A RACK.....</u>	<u>2.1</u>
2.4	<u>INSTALLING ON A WALL.....</u>	<u>2.4</u>
2.5	<u>CONNECTING GROUND WIRES.....</u>	<u>2.8</u>
3	<u>INSTALLING AND REPLACING BOARDS</u>	
3.1	<u>CABINET CONFIGURATION.....</u>	<u>3.1</u>
3.2	<u>MCP/MP20 AND LCP MODULES.....</u>	<u>3.3</u>
3.3	<u>INTERFACE BOARDS.....</u>	<u>3.13</u>
3.4	<u>CONNECTING POWER FAIL TRANSFER.....</u>	<u>3.58</u>
4	<u>CONNECTING EXTERNAL BATTERIES</u>	
4.1	<u>CONNECTING EXTERNAL BATTERIES.....</u>	<u>4.1</u>
5	<u>CONNECTING POWER</u>	
5.1	<u>BEFORE CONNECTING POWER.....</u>	<u>5.1</u>
5.2	<u>PROCEDURE FOR CONNECTING POWER.....</u>	<u>5.1</u>
5.3	<u>CONNECTING THE OFFICESERV 7150 EXTERNAL PoE PSU SUPPLEMENTAL POWER SUPPLY.....</u>	<u>5.3</u>
6	<u>CONNECTING C.O. LINES</u>	
6.1	<u>SAFETY PRECAUTIONS.....</u>	<u>6.1</u>
6.2	<u>CONNECTING C.O. LINES.....</u>	<u>6.2</u>

7	<u>CONNECTING STATIONS AND ADDITIONAL EQUIPMENT</u>	
7.1	CONNECTING STATIONS	7.1
7.2	CONNECTING ADDITIONAL EQUIPMENT	7.33
8	<u>POWER UP PROCEDURES</u>	
8.1	PRE-CHECK.....	8.1
8.2	STARTING THE SYSTEM.....	8.1
8.3	CHECKING THE FAN	8.3
8.4	NUMBERING EXTENSIONS AND C.O. LINES	8.3
9	<u>SOFTWARE AND DATABASE MANAGEMENT</u>	
9.1	SOFTWARE MANAGEMENT on MCP and MP20	9.1
9.2	DATABASE MANAGEMENT	9.1
10	<u>ADDING CARDS TO THE SYSTEM</u>	
10.1	ADDING STATIONS AND TRUNKS.....	10.1

FIGURES

Figure 2.1	<u>Tools Required for Rack Installation</u>
Figure 2.2	<u>Rack Installation (1)</u>
Figure 2.3	<u>Rack Installation (2)</u>
Figure 2.4	<u>Rack Installation (3)</u>
Figure 2.5	<u>Rack Installation (4)</u>
Figure 2.6	<u>Tools Required for Wall Installation</u>
Figure 2.7	<u>Wall Installation (1)</u>
Figure 2.8	<u>Wall Installation (2)</u>
Figure 2.9	<u>Wall Installation (3)</u>
Figure 2.10	<u>Wall Installation (4)</u>
Figure 2.11	<u>Wall Installation (5)</u>
Figure 2.12	<u>Wall Installation (6)</u>
Figure 2.13	<u>Grounding</u>
Figure 3.1	<u>Front Panel Configuration</u>
Figure 3.2	<u>Back Panel Components</u>
Figure 3.3a	<u>MCP Switch Settings</u>
Figure 3.3b	<u>MP20 Switch Settings</u>
Figure 3.4	<u>Installing the Processor Board (1)</u>
Figure 3.5	<u>Installing the Processor Board (2)</u>
Figure 3.6	<u>Link Cables</u>

[Figure 3.7 Connecting MCP/MP20 Board to LCP Board](#)

[Figure 3.8a Front View of the MCP with Smart Media /
Front View of MCP with Media Card \(MMC+\)](#)

[Figure 3.8b Front View of MP20](#)

[Figure 3.9 Front View of the LCP](#)

[Figure 3.10 Installing Optional Modem Daughtercards on MP20 Only](#)

[Figure 3.11 Installing Optional Daughterboard on MCP/MP20](#)

[Figure 3.12 Installing Interface Board into Slot](#)

[Figure 3.13 Front Panel Lever](#)

[Figure 3.14 Turning the Cabinet Power Off](#)

[Figure 3.15 Removing Cable](#)

[Figure 3.16 Removing Board](#)

[Figure 3.17 Replacing a Board](#)

[Figure 3.18 Setting Switches on the TEPRI Board](#)

[Figure 3.19 Setting Switches on the TEPRIa Board](#)

[Figure 3.20 Front View of the TEPRI](#)

[Figure 3.21 Front View of the TEPRIa](#)

[Figure 3.22 Front View of the 8TRK](#)

[Figure 3.23 Front View of the 8TRK2](#)

[Figure 3.24 Front View of the 16TRK](#)

[Figure 3.25 Front View of the 16DLI2](#)

[Figure 3.26 Front View of the 8DLI](#)

[Figure 3.27 Front View of the 8COMBO](#)

[Figure 3.28 Front View of the 8COMBO2](#)

[Figure 3.29 Front View of the 16SLI2](#)

[Figure 3.30 Front View of the 16MWSLI](#)

[Figure 3.31 Front View of the 8SLI](#)

[Figure 3.32 Front View of the 8SLI2](#)

[Figure 3.33 Jumper Setting of WIM Board](#)

[Figure 3.34 Front View of the WIM Board](#)

[Figure 3.35 V.35 Cable Pin Outs](#)

[Figure 3.36 SIO Connector, RJ45 Pin Assignment](#)

[Figure 3.37 Front View of the PLIM Board](#)

[Figure 3.38 Front View of the PLIM2 Board](#)

[Figure 3.39 Setting the Jumpers of PLIM2 Board](#)

[Figure 3.40 Front View of the GPLIMT](#)

[Figure 3.41 Front View of the GSIMT](#)

[Figure 3.42 Mounting Optional Board on MGI Board](#)

- [Figure 3.43 Front View of the MGI Board](#)
- [Figure 3.44 Front View of the MGI-16 Board](#)
- [Figure 3.45 Front View of the OAS](#)
- [Figure 3.46 Front View of the 4WLI Board](#)
- [Figure 3.47 Front View of the 4DSL Board](#)
- [Figure 3.48 4DSL Card Ports \(P1~P4\) Wiring Pinout](#)
- [Figure 3.49 SVMi-20E LED Indications](#)
- [Figure 3.50 4VPM \(VPM-E, VPM-F\) and 8VPM \(8VPMF-E\) Combinations](#)
- [Figure 3.51 SVMi-20E/HD with no optional boards installed \(LEFT\) and SVMi-20E/CF with all components installed \(RIGHT\)](#)
- [Figure 3.52 Front View of the CNF24 Card](#)
- [Figure 3.53 CNF24 Slot Information](#)
- [Figure 3.54 CNF24 Parameter Settings](#)
- [Figure 3.55 Input Service License Key](#)
- [Figure 3.56 CNF24 License](#)
- [Figure 3.57 CNF24 Package Update](#)
- [Figure 3.58 CNF24 Progress Bar](#)
- [Figure 3.59 Power Fail Transfer Connection to 16MWSLI/16SLI2/8SLI/8SLI2](#)
- [Figure 4.1 Connecting an External Battery \(1\)](#)
- [Figure 4.2 Connecting an External Battery \(2\)](#)
- [Figure 5.1 Connecting Power \(for Single Cabinet\)](#)
- [Figure 5.2 Connecting Power \(using Power Cable\)](#)
- [Figure 5.3 Connecting Power \(using Power Extension Cable\)](#)
- [Figure 5.4 Front View of OS 7150 Cabinet](#)
- [Figure 5.5 Rear View of OS 7150 Cabinet](#)
- [Figure 5.6 Tools Needed for Installation in a Rack](#)
- [Figure 5.7 OS 7150 Installation in a Rack \(1\)](#)
- [Figure 5.8 OS 7150 Installation in a Rack \(2\)](#)
- [Figure 5.9 OS 7150 Installation in a Rack \(3\)](#)
- [Figure 5.10 OS 7150 Installation in a Rack \(4\)](#)
- [Figure 5.11 OS 7150 Grounding](#)
- [Figure 5.12 Connecting an External Battery](#)
- [Figure 5.13 Power Connection](#)
- [Figure 5.14 Connecting OS 7150 to OS 7200](#)
- [Figure 6.1 Tip and Ring Connections to Analog Trunk Cards](#)
- [Figure 6.2 RJ-45 Port of TEPRI/TEPRIa Board](#)
- [Figure 7.1 RJ-45 Port of the 8SLI](#)
- [Figure 7.2 RJ-45 Port of the 16SLI2](#)

- [Figure 7.3 RJ-45 Port of the 8COMBO/8COMBO2 \(For Analog Phone\)](#)
- [Figure 7.4 RJ-45 Port of the 8DLI \(For Digital Phone\)](#)
- [Figure 7.5 RJ-45 Port of the 16DLI2 \(For Digital Phone\)](#)
- [Figure 7.6 RJ-45 Port of the 8COMBO/8COMBO2 \(For Digital Phone\)](#)
- [Figure 7.7 LAN Connections](#)
- [Figure 7.8 RJ-45 Port of 4WLI](#)
- [Figure 7.9 Connecting a Door Phone and a Door Lock](#)
- [Figure 7.10 Adding an iDCS Keypad Daughterboard Module](#)
- [Figure 7.11 Keypad Base](#)
- [Figure 7.12 Installing KDB-DLI Daughterboard](#)
- [Figure 7.13 Keypad Daughterboard Output Jack](#)
- [Figure 7.14 Connecting Keypad Daughterboard to Keypad PCB](#)
- [Figure 7.15 Installing KDB-SLI Daughterboard](#)
- [Figure 7.16 Connecting a Keypad to KDB-DLI](#)
- [Figure 7.17 Connecting a Single Line Telephone to a KDB-SLI](#)
- [Figure 7.18 Connecting a Station Device to a KDB via MDF](#)
- [Figure 7.19 Wall-Mounting a Keypad](#)
- [Figure 7.20 Ultra Base Wedge](#)
- [Figure 7.21 Wall-Mounting an iDCS Keypad](#)
- [Figure 7.22 Wall-Mounting DS 5000, ITP-5121D and ITP-5107S Keypads](#)
- [Figure 7.23 Attaching 24B/12B to 64 Button Module](#)
- [Figure 7.24 Attaching 24B/12B to AOM](#)
- [Figure 7.25 Attaching 7B/Single Line to AOM or to 64 Button Module](#)
- [Figure 7.26 Attaching the iDCS 64 Button Module to an iDCS Keypad](#)
- [Figure 7.27 Attaching iDCS 14 Button AOM to an iDCS Keypad](#)
- [Figure 7.28 Attaching DS 64 Button Modules to a DS 5021D or a DS 5014D Keypad](#)
- [Figure 7.29 Attaching SMT-i5264 AOM to Phone](#)
- [Figure 7.30 Setting-Up SMT-i5264 AOM](#)
- [Figure 7.31 IP AOM Network Configuration](#)
- [Figure 7.32 Connecting MOH/BGM Sources](#)
- [Figure 7.33 Connecting External/Additional Page Equipment](#)
- [Figure 7.34 Connecting Common Bell](#)
- [Figure 7.35 OSM/OIT Connection to PLIM/PLIM2 Board via LAN](#)
- [Figure 7.36 OSM Screen](#)
- [Figure 7.37 Setting OSM Parameters](#)
- [Figure 7.38 Link Control: Site List Tab](#)
- [Figure 7.39 Site List: Detailed Information](#)
- [Figure 7.40 Site List: Link Type Modem](#)

- [Figure 7.41 Link Control: Option Tab](#)
- [Figure 7.42 Security Settings to Enable Downloads](#)
- [Figure 7.43 Enable Pop-Ups](#)
- [Figure 7.44 Java](#)
- [Figure 7.45 Trusted Sites](#)
- [Figure 7.46 Firewall Ports](#)
- [Figure 7.47 DM Splash Screen](#)
- [Figure 7.48 Security Warning](#)
- [Figure 7.49 DM Login Page](#)
- [Figure 7.50 OS Device Manager Client Application Open Screen](#)
- [Figure 7.51 Link Setup](#)
- [Figure 7.52 Site Links](#)
- [Figure 7.53 MODEM Options](#)
- [Figure 7.54 Connect to an OS System Using Client App Method 1](#)
- [Figure 7.55 Connect to an OS System Using Client App Method 2](#)
- [Figure 7.56 DM Login Page](#)
- [Figure 7.57 Connecting SMDR to the LAN Port of the PLIM/PLIM2](#)

TABLES

- [Table 1.1 Power Specifications](#)
- [Table 3.1 Applicable Boards per Slot](#)
- [Table 3.2 Back Panel Parts](#)
- [Table 3.3 Types of Control Boards](#)
- [Table 3.4 Ports and LEDs of the MCP/MP20](#)
- [Table 3.5 Ports and LEDs of the LCP](#)
- [Table 3.6 Types of Interface Board and Applicable Slots](#)
- [Table 3.7 Ports and LEDs of the TEPR1](#)
- [Table 3.8 Ports and LEDs of the TEPR1a](#)
- [Table 3.9 Ports and LEDs of the 8TRK](#)
- [Table 3.10 Ports and LEDs of the 16TRK](#)
- [Table 3.11 Ports of the 16DLI2](#)
- [Table 3.12 Ports and LEDs of the 8DLI](#)
- [Table 3.13 16SLI2/16MWSLI Board Ports](#)
- [Table 3.14 Ports and LEDs of the 8SLI/8SLI2](#)
- [Table 3.15 Ports and LEDs of the WIM](#)
- [Table 3.16 Ports and LEDs of the PLIM](#)

<u>Table 3.17</u>	<u>Ports and LEDs of the PLIM2</u>
<u>Table 3.18</u>	<u>Ports and LEDs of the GPLIMT</u>
<u>Table 3.19</u>	<u>Ports and LEDs of the GSIMT</u>
<u>Table 3.20</u>	<u>Ports and LEDs of the MGI-16</u>
<u>Table 3.21</u>	<u>OAS Front Panel Components</u>
<u>Table 3.22</u>	<u>Ports and LEDs of the 4WLI</u>
<u>Table 3.23</u>	<u>Ports and LEDs of the 4DSL</u>
<u>Table 3.24</u>	<u>VPM Configuration</u>
<u>Table 3.25</u>	<u>CNF24 Front Panel Components</u>
<u>Table 3.26</u>	<u>Maximum Conference Capacity</u>
<u>Table 3.27</u>	<u>CNF24 Port Association</u>
<u>Table 5.1</u>	<u>Consumption per Device</u>
<u>Table 5.2</u>	<u>Input Voltage and Frequency</u>
<u>Table 5.3</u>	<u>Rated Output in the Case of Operation with AC</u>
<u>Table 5.4</u>	<u>Rated Output in the Case of Operation with DC</u>
<u>Table 6.1</u>	<u>OfficeServ 7200 Line Conditions</u>
<u>Table 7.1</u>	<u>Distance Between Stations and the System</u>
<u>Table 7.2</u>	<u>Specification for Wireless LAN Connection</u>
<u>Table 7.3</u>	<u>OfficeServ Manager Specification</u>
<u>Table 7.4</u>	<u>Minimum PC Requirements for Installation Tool</u>
<u>Table 7.5</u>	<u>Minimum Software Version Requirements for Installation Tool</u>
<u>Table 7.6</u>	<u>Link Control Parameters</u>
<u>Table 7.7</u>	<u>Modem Configuration</u>
<u>Table 7.8</u>	<u>DM Embedded Application Web Browser Requirements</u>
<u>Table 7.9</u>	<u>Client Application PC Requirements</u>
<u>Table 7.10</u>	<u>Embedded Application Software Compatibility</u>

PART 1. PRE-INSTALLATION INFORMATION

1.1 SITE REQUIREMENTS

Select a location that satisfies the following conditions for safety, temperature, humidity, power and grounding.

1.1.1 Safety Conditions

- The OfficeServ 7200 system should not be installed near materials that can cause a fire, such as explosive gas and inflammables. The OfficeServ 7200 system should not be near equipment that generate electromagnetic waves, such as monitors or copying machines.
- The installation location should be convenient for distributing trunk lines and extension lines, for connecting power and grounding wires, and for maintenance and repair.
- The OfficeServ 7200 system should not be installed in aisles or passageways that are populated or used for moving equipment.
- Always maintain cleanliness to prevent dust from damaging the board connectors of the cabinet.
- Before installing the OfficeServ 7200 system, check items such as the electrical wiring status, grounding status, voltage and frequency.
- Do not expose equipment to direct sun light, corrosive fumes, and constant vibrations.
- Do not install in close proximity to a fire sprinkler or other sources of water.
- A dedicated commercial AC power outlet is required. Do not use extension cords.
- Ensure that all wires and cables to and from the OfficeServ 7200 do not cross fluorescent lights or run in parallel with AC wires.
- This equipment is to be installed only in restricted access areas (dedicated, equipment closets, etc.) in accordance with articles 110-16, 110-17, 110-18 of the National Electric Code, ANSI/NFPA 70.

1.1.2 Temperature/Humidity Conditions

The conditions for temperature and humidity are as follows:

- Operation temperature: 32°F~113°F
- Storage temperature: 14°F~122°F
- Humidity: 10~90%

1.2 GROUNDING CONDITIONS

An equipment grounding conductor that is not smaller in size than the ungrounded branch-circuit supply conductors is to be installed as part of the circuit that supplies the product or system. Bare, covered, or insulated grounding conductors are acceptable. Individually covered or insulated equipment grounding conductors shall have a continuous outer finish that is either green or green with one or more yellow stripes. The equipment grounding conductor is to be connected to ground at the service equipment.

The attachment-plug receptacles in the vicinity of the product or system are all to be of a grounding type, and the equipment grounding conductors serving these receptacles are to be connected to earth ground at the service equipment.

WARNING: HIGH LEAKAGE CURRENT! Earth connection is essential before connecting supply.

The OfficeServ 7200 system requires that a supplementary earth ground be connected to the system. This is the preferred method of grounding the OfficeServ 7200. It should be noted that when the third wire ground becomes inferior it may prevent the digital data bus from canceling out noise. This may result in erratic operation of the OfficeServ 7200. Another problem that has occurred is that some UPS battery systems do not pass the ground through to the power cord resulting in no ground to the system. The ground lug in the back of the cabinet must be connected to one of the following: bonded building steel, cold water pipe, or a ground rod using at least #16 AWG copper wire. Additionally, the ground between cabinets in a multiple cabinet system must also be at least #16 AWG copper wire. The third wire AC ground or field ground is connected to the system frame via the ground strap from the ground connector on the AC socket.

A supplementary equipment grounding conductor shall be installed between the system and ground that is in addition to the equipment grounding conductor in the power supply cord.

The supplementary equipment grounding conductor shall not be smaller in size than the ungrounded branch-circuit supply conductors. The supplementary equipment grounding conductor shall be connected to the product at the terminal provided, and shall be connected to ground in a manner that will retain the ground connection when the product is unplugged from the receptacle. The connection to ground of the supplementary equipment grounding conductor shall be in compliance with the rules for terminating bonding jumpers in Part K of Article 250 of the National Electrical Code ANSI/NFPA 70. Termination of the supplementary equipment grounding conductor is permitted to be made to building steel, to a metal electrical raceway system, or to any grounded item that is permanently and reliably connected to the electrical service equipment ground.

Bare, covered, or insulated grounding conductors are acceptable. A covered or insulated grounding conductor shall have a continuous outer finish that is either green or green with one or more yellow stripes.

Failure to provide an adequate ground may cause a safety hazard, confusing trouble symptoms, or even circuit card failure.

WARNING: Unplug the power cord from the AC outlet before attempting to connect the ground. Hazardous voltage may cause death or injury. Observe extreme caution when working with AC power. Remove lines from trunk cards.

What the above paragraphs mean is that when conventional analog telephone circuits are connected to the OfficeServ 7200 system, under fault conditions (i.e., the tip and/or ring conductor is crossed with a power line, or the circuit is affected by lightning during a storm), it is possible for hazardous potentials to appear across the tip and ring wiring coming into the OfficeServ 7200 cabinet(s) from the outside plant (i.e., overhead cables, buried cables, cable head pedestal). These circuits are provided with both primary and secondary protection circuitry which will attempt to drain off these high voltages and currents to earth ground. Obviously, it is important to have a good source of ground connected to the OfficeServ 7200 system to drain this energy off. Again, a good earth ground source is required by the OfficeServ 7200 system.

The OfficeServ 7200 system has two ground reference points. One point is via the green wire in the power cord connected to the AC power outlet. This ground connection is provided to meet local electrical codes when the AC ground is required to be common with the earth ground. However, this can be disconnected either intentionally or unintentionally. Consequently, a more permanent ground connection is required by connecting a high current/voltage capacity ground wire which is bonded to ground at the electric service power entrance or via some other method approved by the National Electrical Code to the OfficeServ 7200 system ground lug. This is a more secure ground connection, which can only be disconnected intentionally. These precautions are taken for safety reasons to protect personnel working on the Office Serv 7200 system and also for operational reasons to accommodate ground return and/or ground-referenced analog telephone circuits, which require this solid earth ground connection for normal functioning.

1.3 POWER CONDITIONS

The power supply board of the OfficeServ 7200 system receives AC input power or battery power, and supplies -48V, -5V, +5V, +3.3V, +12V, and -56V to the system cabinet.

The rating is as follows:

- RATING: AC 110-120V; 6A; 50/60Hz or DC 48V 3A

Table 1.1 Power Specifications

Power Supply Unit(PSU)		Specification
PSU	Input power	AC 110V DC 48V (DC 48V for battery backup ONLY)
	Output power	- DC 48V, 2.2A - DC +5V, 8.0A - DC -5V, 1.0A - DC +3.3V, 10A - DC +12V, 0.4A - DC -56V, 0.4A (for battery backup)

1.4 UNPACKING AND INSPECTION

The OfficeServ 7200 can be configured as a single cabinet or dual cabinet system.

All OfficeServ 7200 cabinets are identical when shipped from Samsung. After unpacking the cabinet(s), inspect for signs of physical damage. If any damage is detected, do not attempt to install the system. Contact Samsung Telecommunications America Technical Support Department.

Check to see that each cabinet carton includes the following:

- OfficeServ 7200 cabinet
- AC Power Cable
- Rack Mount Side Flange Brackets (2)
- Rack Mount Cross Bar (1)
- Screw Pack
- Battery Cable Assembly
- Blanking Plates (3)

PART 2. INSTALLING CABINETS

This section describes how to install an OfficeServ 7200 cabinet on a table/desktop in a data rack or on a wall, depending on the installation environment.

2.1 SYSTEM INSTALLATION PROCEDURE

The procedure for system installation is as follows:

- 1) Install the OfficeServ 7200 cabinet on a table, inside a data rack or on the wall depending on the installation environment.
- 2) Connect the ground to the ground lug behind the main cabinet.
- 3) Put the MCP/MP20 board into slot 0 of the main cabinet. If there is an expansion cabinet, install the LCP board into slot 0 of the expansion cabinet.
- 4) Install interface boards into universal slots (slots 1 through slot 5) of the main cabinet and if required slots 1 through 5 of the expansion cabinet.
- 5) Connect an external battery with proper capacity if required.
- 6) Connect AC 110V input power.

2.2 SELECTING INSTALLATION METHOD

The OfficeServ 7200 cabinet can be installed on a table, inside a 19-inch rack or on a wall depending on the number of cabinets and environment of the installation area.

2.3 INSTALLING IN A RACK

2.3.1 Cautions for Installation

Take the following precautions when installing the OfficeServ 7200 cabinet inside a rack:

- The 19-inch rack should be a standard equipment rack.
- When using an enclosed-type rack, check if the rack is properly ventilated. Vents should be equipped on the side of the rack and fans should be attached to ventilate cool air into the rack.
- Take special caution when using an enclosed-type rack that has vents on top of the rack since hot air coming out of the vent may enter the intake vent of a system installed above the rack.
- When using an open rack, do not block the entrance of a port or fan of the OfficeServ 7200 system.

2.3.2 Required Tools

- A mid-sized Phillips screwdriver
- A bracket and three screws for attaching cabinet to rack mount
- Two brackets and six screws for rack mount
- Two screws for fastening

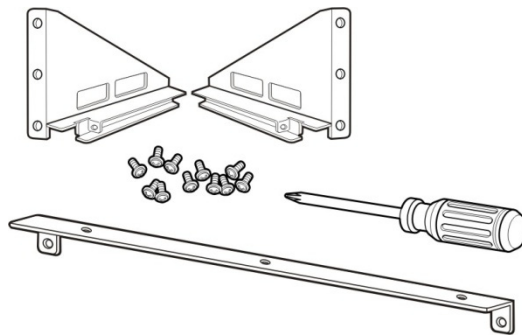

Figure 2.1 Tools Required for Rack Installation

2.3.3 Installing in a Rack

The procedure for installing the OfficeServ 7200 cabinet inside a 19-inch rack is as follows:

- 1) Attach the cabinet bracket to the bottom surface of the OfficeServ 7200 cabinet and fasten the bracket firmly with the three screws.

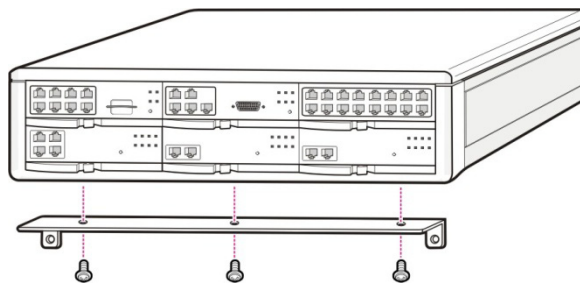

Figure 2.2 Rack Installation (1)

- 2) Attach the rack brackets to both sides of the rack and fasten the brackets firmly with the six screws.

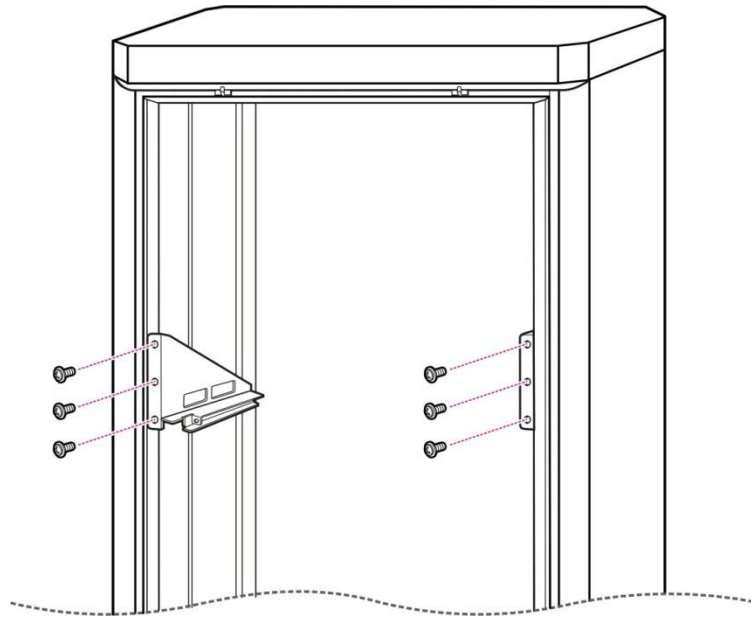

Figure 2.3 Rack Installation (2)

- 3) Align the cabinet to the guardrails of the rack and slide the cabinet into the rack.

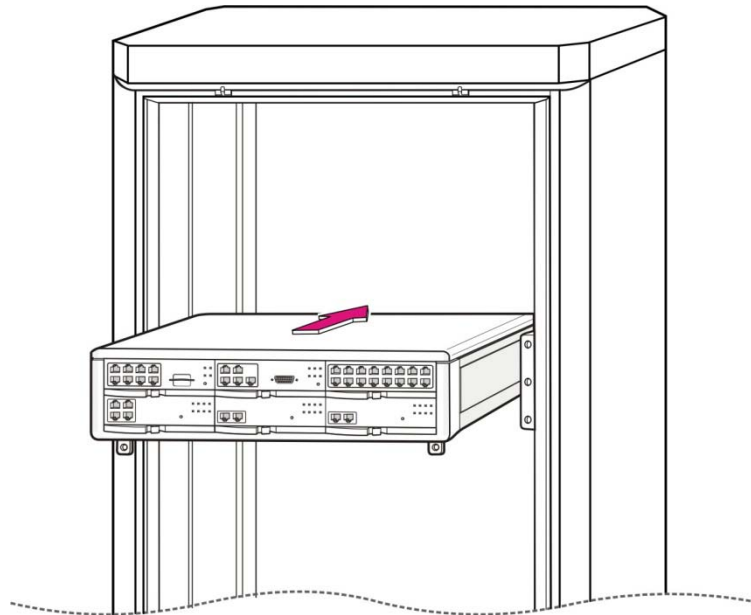

Figure 2.4 Rack Installation (3)

- 4) Align the two holes of the cabinet bracket and the holes of the rack brackets, and fasten the cabinet to the rack with the two screws.

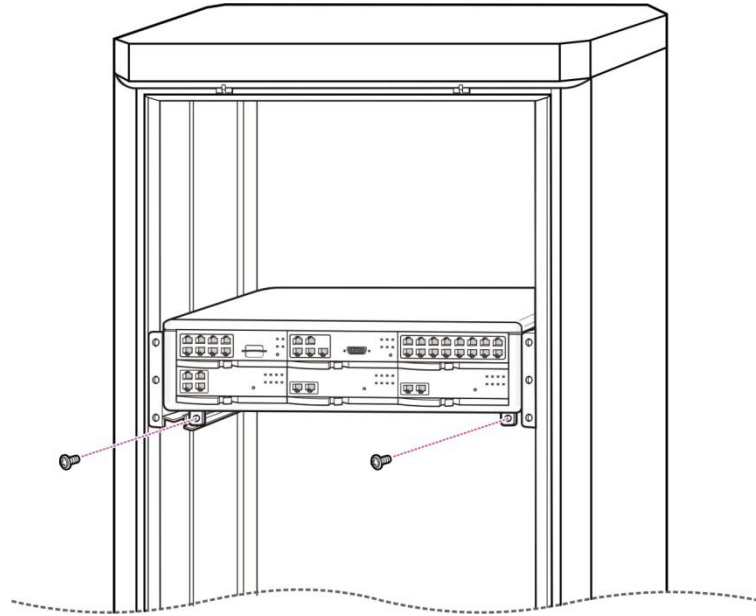

Figure 2.5 Rack Installation (4)

- 5) The above steps 1~4 also apply to expansion cabinets.

2.4 INSTALLING ON A WALL

This section describes how to install the OfficeServ 7200 cabinet on a wall. The optional OfficeServ 7200 wall mount bracket is required (must be ordered separately).

2.4.1 Required Tools

- A mid-sized Phillips screwdriver
- An electric drill
- A hammer
- A wall bracket
- Four plastic anchors
- Four Phillips screws
- Four install lock screws

- Two screws that are already screwed in the bottom of the OfficeServ 7200 cabinet.

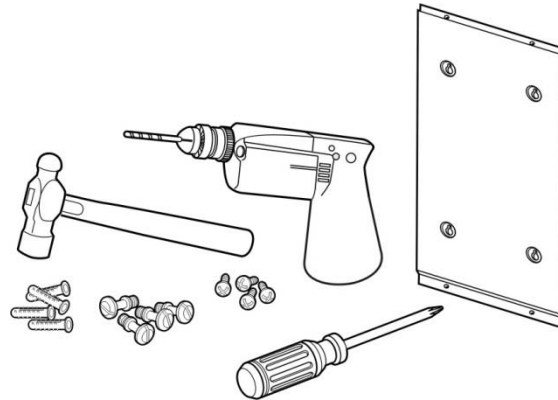

Figure 2.6 Tools Required for Wall Installation

2.4.2 Wall Installation

The procedure for installing the OfficeServ 7200 cabinet on a wall by using a wall bracket is as follows:

CAUTION: Only mount OfficeServ 7200 onto a wall capable of supporting the combined weight of 2 cabinets; associated blocks, cables and peripheral equipment.

- 1) There are four screw holes (see [A] Figure 2.7) on the wall bracket as shown below. Mark the four screw holes where the wall bracket should be installed.

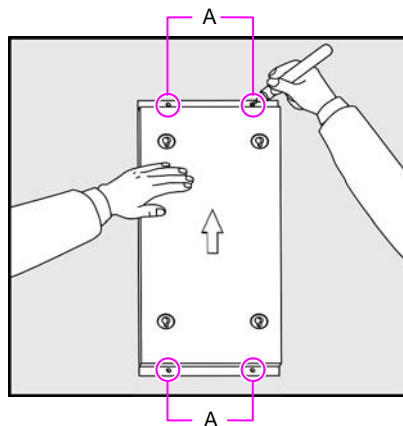

Figure 2.7 Wall Installation (1)

- 2) Use the electrical drill to make holes where the screw holes were marked.

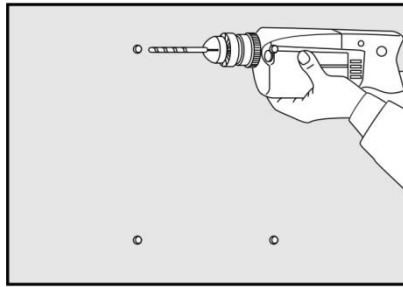

Figure 2.8 Wall Installation (2)

- 3) Select appropriate screws, toggle bolts, or plastic anchors to suit the selected mounting surface.
- 4) Secure the bracket to the wall using appropriate hardware.

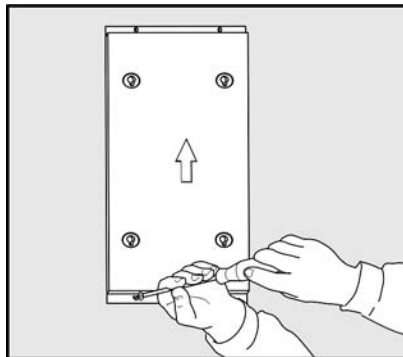

Figure 2.9 Wall Installation (3)

- 5) There are two screws in two of the four holes at the bottom of the OfficeServ 7200 cabinet as shown below. To install on the wall, loosen the two screws to approximately 2mm as shown in Figure 2.10.

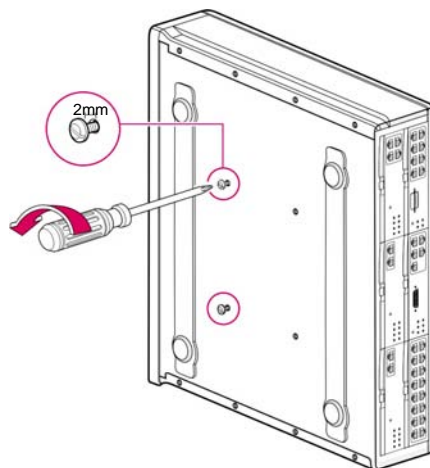

Figure 2.10 Wall Installation (4)

- 6) Tighten two more screws to the other two holes which do not have screws at the bottom of the OfficeServ 7200 cabinet. Do not tighten the screws all the way in but leave about 2 mm space.

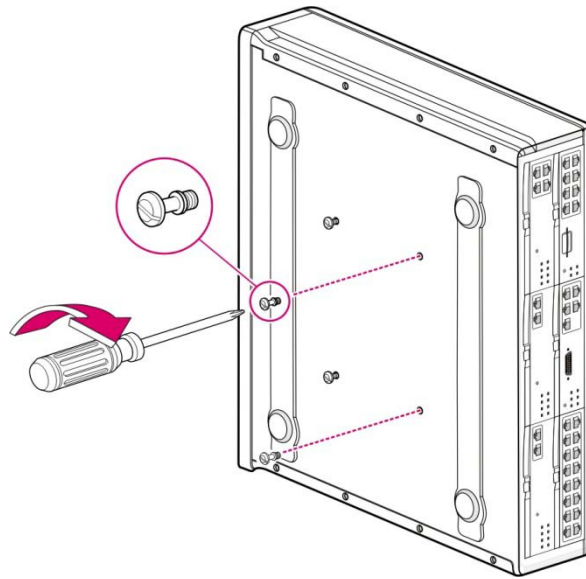

Figure 2.11 Wall Installation (5)

- 7) Hang the screws on the bottom surface of the OfficeServ 7200 cabinet to the holes of the wall bracket and push the cabinet downward to fix the cabinet.

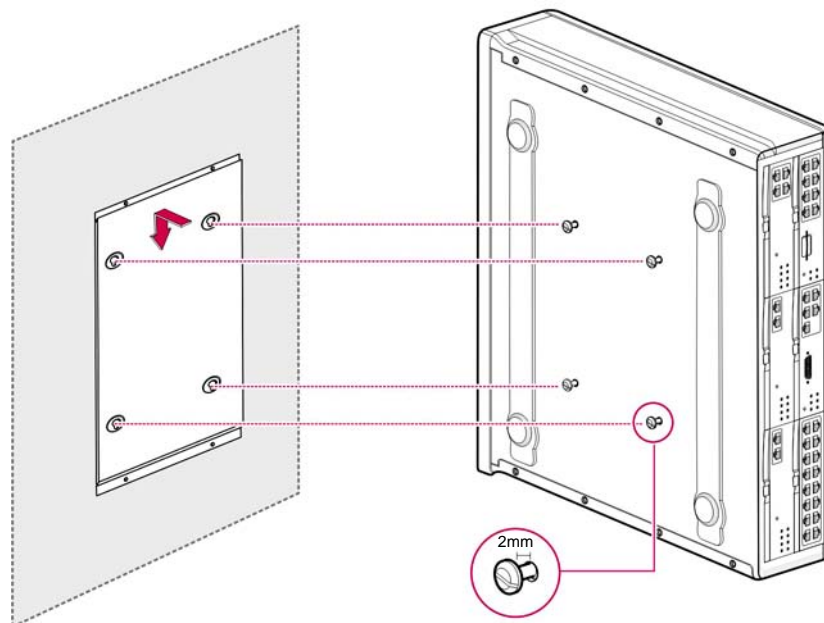

Figure 2.12 Wall Installation (6)

2.5 CONNECTING GROUND WIRES

This section describes how to connect an external grounding wire to the OfficeServ 7200 system.



External Grounding

External grounding is required to prevent human injuries and system damage caused by lightning, static electricity, or voltage surge.

As shown in the figure below, connect an earth ground to the ground lug behind the OfficeServ 7200. For an expansion cabinet, connect and ground the external ground wire between the expansion cabinet and the main cabinet.

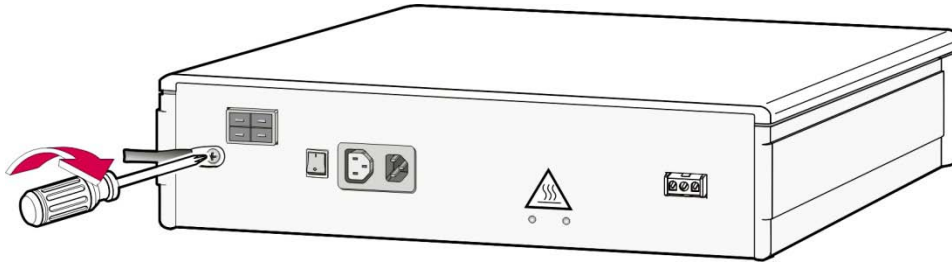

Figure 2.13 Grounding

IMPORTANT: Follow the grounding requirements described in Section 1.2 (Grounding Conditions) when connecting a ground to the system.

PART 3. INSTALLING AND REPLACING BOARDS

This section describes how to install and replace various boards of the OfficeServ 7200 system.

3.1 CABINET CONFIGURATION

The main and expansion cabinets of the OfficeServ 7200 system have six slots each.



Figure 3.1 Front Panel Configuration

The following boards may be installed in the cabinet slots according to the configuration of the OfficeServ 7200.

Table 3.1 Applicable Boards per Slot

Cabinet	Slot	Applicable Boards
Expansion Cabinet	Slot 0	For LCP ONLY
	Slot 1	All boards EXCEPT MCP/MP20, LCP, TEPRI/TEPRIa and PLIM/PLIM2
	Slot 2	All boards EXCEPT MCP/MP20, LCP, TEPRI/TEPRIa and WIM
	Slot 3	All boards EXCEPT MCP/MP20, LCP and WIM
	Slot 4, 5	All boards EXCEPT MCP/MP20, LCP, TEPRI/TEPRIa and WIM
Main Cabinet	Slot 0	For MCP/MP20 ONLY
	Slot 1	All boards EXCEPT MCP/MP20, LCP, TEPRI/TEPRIa and PLIM/PLIM2
	Slot 2	All boards EXCEPT MCP/MP20, LCP, TEPRI/TEPRIa and WIM
	Slot 3, 4, 5	All boards EXCEPT MCP/MP20, LCP and WIM



Checking Slots

The WIM board can only be installed in slot 1 of the main cabinet or slot 1 of the expansion cabinet, and the TEPRI/TEPRIa can only be installed on slots 3, 4 and 5 of the main cabinet and slot 3 of the expansion cabinet.

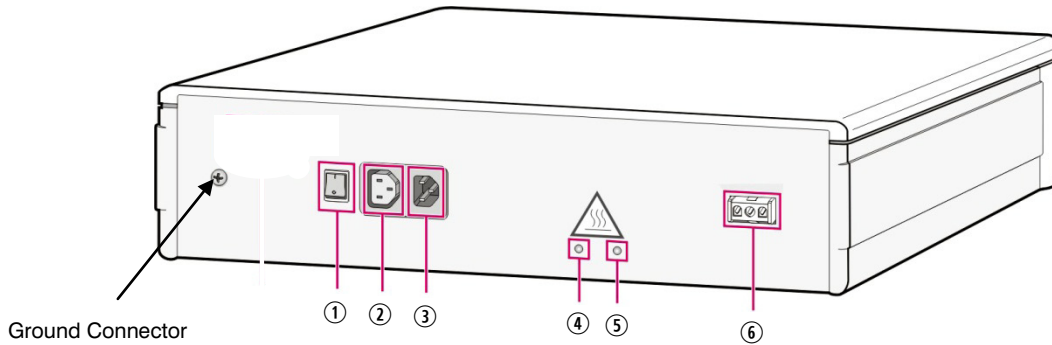

Figure 3.2 Back Panel Components

Back panel components:

Table 3.2 Back Panel Parts

Parts	Description
① Power switch	Switches the power of OfficeServ 7200 on/off.
② Power connector between a basic cabinet and an extension cabinet	Extends 110V AC power from basic cabinet to expansion cabinet.
③ AC Power Cord "IN"	Connects to a grounded electrical outlet on a dedicated circuit.
④ AC LED	Is lit for the AC input power.
⑤ DC LED	Is lit for the DC output power (internal DC voltage)
⑥ Battery Backup connector	Connects an external battery source "48V DC only"

3.2 MCP/MP20 AND LCP MODULES

This section describes the procedures for setting switches, installing optional daughter boards, installing the boards in a slot, and how to connect between the MCP/MP20 and LCP boards.

The OfficeServ 7200 MCP/MP20 (Main Control Processor) controls the system operation. The MCP/MP20 is required for all configurations and goes in slot 0 of the main cabinet. The LCP goes in slot 0 of the expansion cabinet.

The LCP is a secondary processor that communicates with the MCP/MP20 and manages the boards in the expansion cabinet.

3.2.1 Setting Switches on the MCP

The MCP board includes switches used for customizing the board to the user requirements and system configuration.

The procedure for setting switches is as follows.

On the MCP, set the switches for the required configuration. The description for the settings is described below.

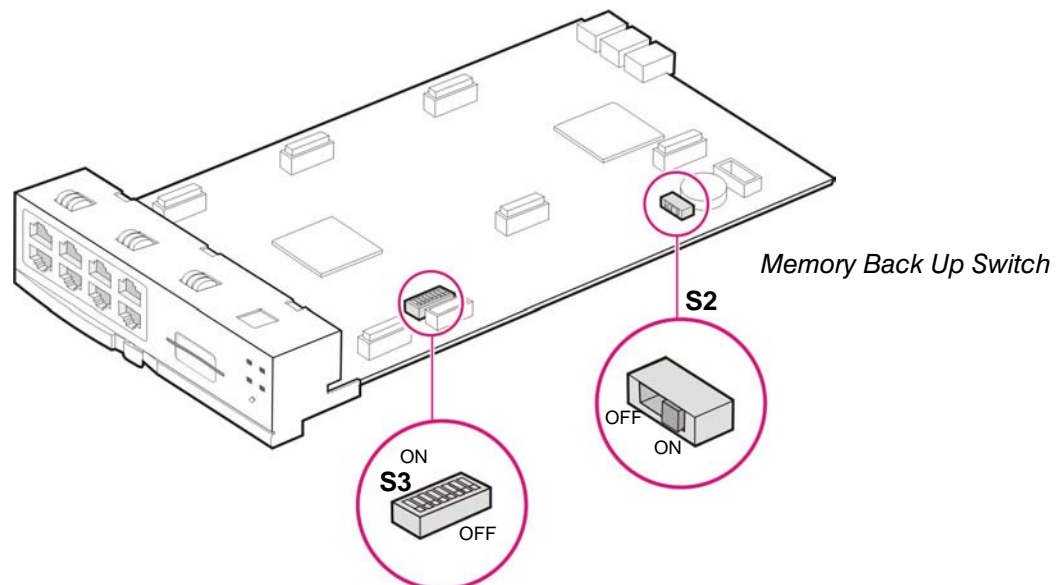

Figure 3.3a MCP Switch Settings

- Memory Backup Switch (S2): When set to ON, all system programming is saved in SRAM. A super capacitor keeps voltage to the SRAM to save the database for approximately 2 to 3 days. [See Section 9.2.1 Database Management on MCP.](#) At that point all programming will

be lost. It is recommended that all programming is saved using Smart Media, MMC+ card, Installation Tool or OfficeServ Manager application. Turning the switch OFF will set the system to DEFAULT. To default the system keep this switch in the OFF position for 30 seconds. Switch to ON position before powering up the system.

DIP SWITCH USE (S3)

ON (left)		OFF (right)
4 DIGIT STATION NUMBERS	SW8	3 DIGIT STATION NUMBERS
4 DIGIT STATION GROUPS	SW7	3 DIGIT STATION GROUPS
4 DIGIT TRUNK NUMBERS	SW6	3 DIGIT TRUNK NUMBERS
RESERVED	SW5	RESERVED
COUNTRY SELECT	SW4	COUNTRY SELECT
COUNTRY SELECT	SW3	COUNTRY SELECT
COUNTRY SELECT	SW2	COUNTRY SELECT
COUNTRY SELECT	SW1	COUNTRY SELECT

- Switches 1 through 4 select the country the system is installed in.

4	3	2	1	Country
OFF	OFF	OFF	OFF	Korea
OFF	OFF	OFF	ON	USA
OFF	OFF	ON	OFF	UK
OFF	OFF	ON	ON	Italy
OFF	ON	OFF	OFF	Australia
OFF	ON	OFF	ON	New Zealand
OFF	ON	ON	OFF	Holland
OFF	ON	ON	ON	Denmark

- Switch 5 is reserved.
- These DIP switches will not take effect unless the switches are set in the wanted position and the system memory is cleared manually by using the Memory Backup switch.

3.2.2 Setting Switches on the MP20

The MP20 processor card does not have a memory backup switch because it uses volatile NAND flash memory to store the database. [See Section 9.2.2, Database Management on the MP20 and use of the RESET button.](#) There is a set of dip switches designated as S3 (see Figure 3.3b, MP20 Switch Settings) used to customize the user requirements and system configuration at start up. The description of each setting is described below.

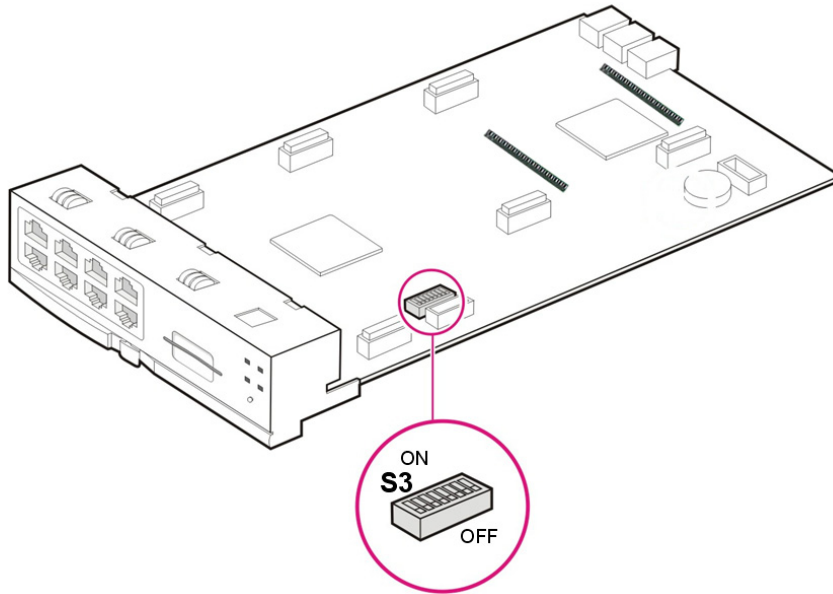

Figure 3.3b MP20 Switch Settings

DIP SWITCH USE (S3)

ON (left)		OFF (right)
4 DIGIT STATION NUMBERS	SW8	3 DIGIT STATION NUMBERS
4 DIGIT STATION GROUPS	SW7	3 DIGIT STATION GROUPS
4 DIGIT TRUNK NUMBERS	SW6	3 DIGIT TRUNK NUMBERS
RESERVED	SW5	RESERVED
COUNTRY SELECT	SW4	COUNTRY SELECT
COUNTRY SELECT	SW3	COUNTRY SELECT
COUNTRY SELECT	SW2	COUNTRY SELECT
COUNTRY SELECT	SW1	COUNTRY SELECT

- Switches 1 through 4 select the country the system is installed in.

4	3	2	1	Country
OFF	OFF	OFF	OFF	Korea
OFF	OFF	OFF	ON	USA
OFF	OFF	ON	OFF	UK
OFF	OFF	ON	ON	Italy
OFF	ON	OFF	OFF	Australia
OFF	ON	OFF	ON	New Zealand
OFF	ON	ON	OFF	Holland
OFF	ON	ON	ON	Denmark

- Switch 5 is reserved.
- Any changes to these switch settings after system start up will require a full system default by holding the RESET button in for 7 seconds. Without this system default RESET any previous settings will be retained even if the system has been shut down and powered up again.

3.2.3 Installing MCP/MP20 and LCP

Install processor boards in slot 0 of the main cabinet and the expansion cabinet. The locations of slot 0 through slot 5 are described in figure 3.1.

Table 3.3 Types of Control Boards

Control Board	Applicable Slot
MCP/MP20	Slot 0 of the main cabinet
LCP	Slot 0 of the expansion cabinet

The installation procedure for the MCP/MP20 and LCP boards is as follows:

- 1) Check the exterior of the MCP/MP20 board and the LCP board for any damage. If damage is found, do not proceed with installation. Contact Samsung Technical Support.

 CAUTION	<p>Power the system OFF when installing or removing boards.</p> <p>POWER TO THE CABINET MUST BE TURNED OFF. Failure to do so will damage the card, cabinet and/or corrupt the data moving along the data bus.</p>
---	---

- 2) Align the MCP/MP20 board to the guardrails of slot 0 of the main cabinet, and slide the MCP/MP20 board into the slot.

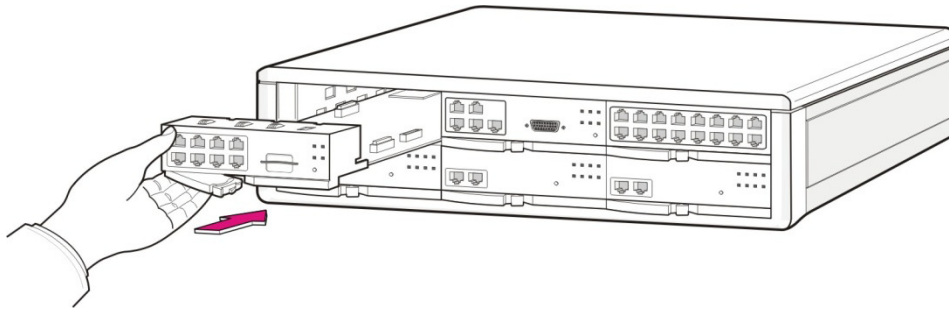

Figure 3.4 Installing the Processor Board (1)

- 3) Push the front panel lever until the board is completely inserted into the OfficeServ 7200 slot 0.

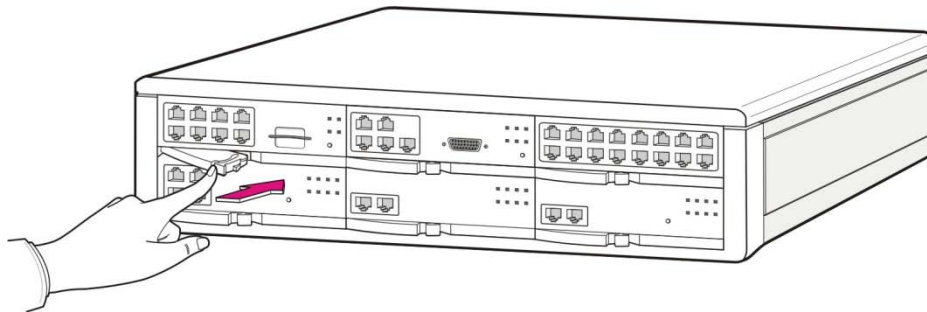

Figure 3.5 Installing the Processor Board (2)

- 4) The above steps 2~3 also apply to installing the LCP board to slot 0 of the expansion cabinet.

3.2.4 Connecting MCP/MP20 to LCP

If the OfficeServ 7200 system consists of a Main Cabinet and an Extension Cabinet, connect the MCP/MP20 board to the LCP board using link cables to transmit and receive signals between the control boards.

- 1) Three link cables are needed to connect the MCP/MP20 board to the LCP board. They are included in the LCP carton.

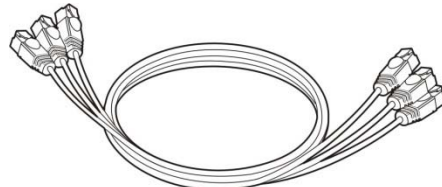

Figure 3.6 Link Cables

- 2) With a link cable, connect the 'Link1' port in MCP/MP20 board installed in the main cabinet and the 'Link1' port in LCP port installed in the expansion cabinet. With the second link cable, connect the 'Link2' port in the MCP/MP20 board and 'Link2' port in the LCP board. With the third link cable, connect the 'Link3' port in the MCP/MP20 board with the 'Link3' port in the LCP board.

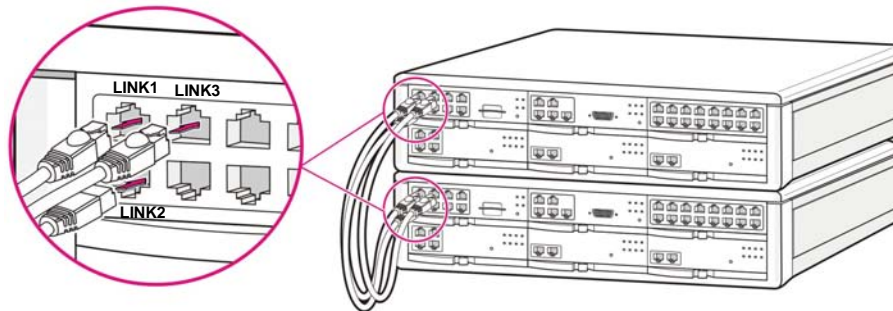

Figure 3.7 Connecting MCP/MP20 Board to LCP Board

3.2.5 MCP/MP20 LEDs

The front view of the MCP board is shown in the picture below.

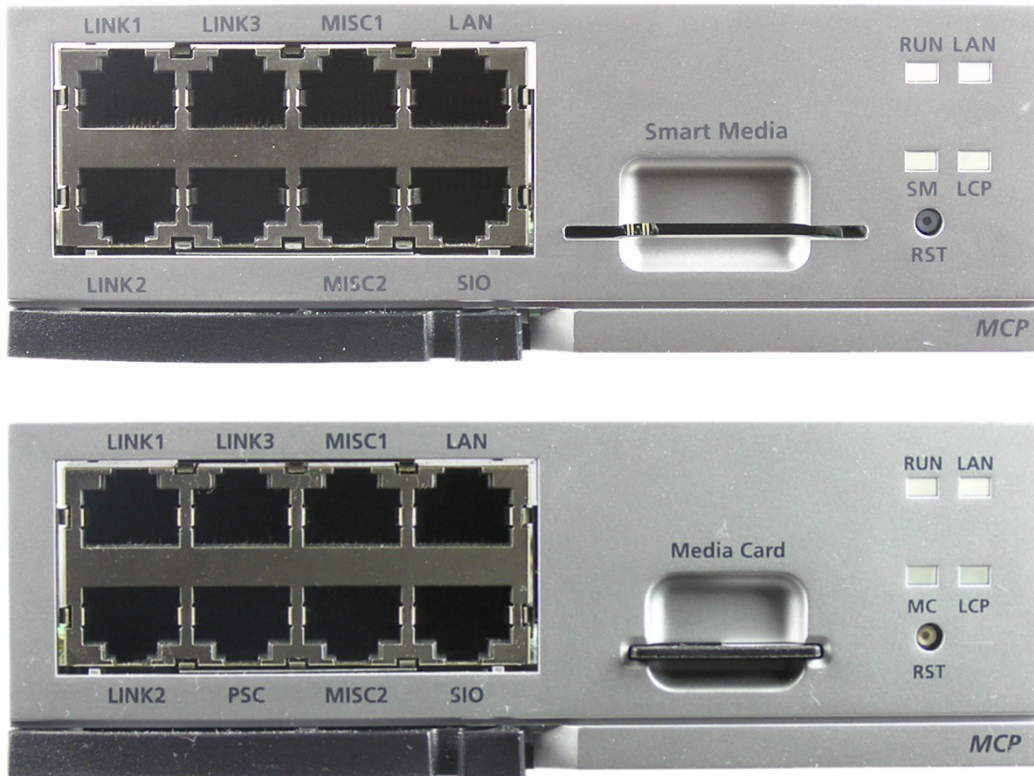

Figure 3.8a Front View of the MCP with Smart Media / Front View of MCP with Media Card (MMC+)

The front view of the MP20 board is shown in the picture below.

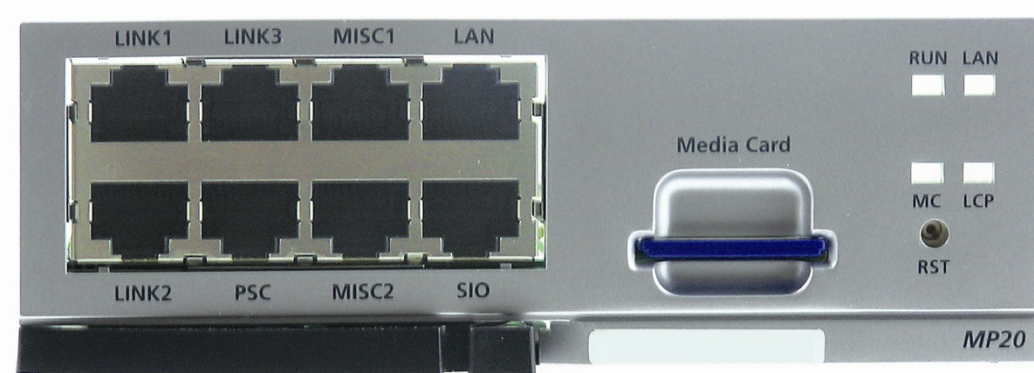

Figure 3.8b Front View of the MP20

The MCP/MP20 front panel components have the functions below:

Table 3.4 Ports and LEDs of the MCP/MP20

Ports & LEDs	Function Description
LINK1~LINK3	Ports that connect the MCP/MP20 to the LCP.
MISC1~MISC2	Ports that connect external music sources, paging device, loud bell, common bell, door bell when the optional MIS daughter board is installed.
Smart Media / Media Card / SD Card	Disk drive for installing the 32MB Smart Media/64MB MMC+/1GB SD card. This card contains the main system software.
LAN	Port for establishing the 10 Base-T/100 Base-Tx Ethernet connection.
SIO	Serial port (Samsung Engineering Use ONLY).
RST	Button for resetting the MCP/MP20 board.
RUN LED	This LED indicates the status of the MCP/MP20. - Off: Power is not connected. - On: Booting - Blink: The program is operating properly
LAN LED	This LED indicates the status of the connection to LAN. - Off: MCP/MP20 is not connected to LAN. - On: MCP/MP20 is connected LAN. - Blink: MCP/MP20 is transmitting or receiving Data through LAN port.
PSC	Connection to the optional OS7150 Alarm Port.
SM LED MC LED	This LED indicates the status of the Smart Media or Media Card access. - Off: The MMC+/Smart Media/SD card is not installed. - On: The MMC+/Smart Media/SD card is installed, however is not accessed. - Blink: The MMC+/Smart Media/SD card is installed and is being accessed.
LCP LED	This LED indicates the status of signaling message processing. - Off: There is no message exchange between MCP/MP20 and LCP. - On: Messages are being sent/received to/from the LCP.

3.2.6 LCP LEDs

The front view of the LCP board is shown in the picture below.



Figure 3.9 Front View of the LCP

The LCP front panel components have the functions below:

Table 3.5 Ports and LEDs of the LCP

Ports & LEDs	Function
LINK1~LINK3	Ports that connect the MCP/MP20 with the LCP.
SIO	Serial port (for Samsung Engineering Use ONLY)
RST	Button for resetting the LCP board.
RUN LED	This LED indicates the status of the LCP. - Off: Power is not connected. - On: Booting. - Blinking: Program in operation.
MCP/MP20 LED	This LED indicates the status of signaling message processing. - Off: There's no message exchange between MCP/MP20 and LCP. - On: Messages are being exchanged between MCP/MP20 and LCP.

3.2.7 Optional Daughterboards

There are 4 types of optional daughter boards that can be installed **ONLY** on the MCP/MP20. Each optional daughterboard must be installed in specific positions of the MCP/MP20 ([see Figure 3.10](#)). Each optional daughterboard is described below:

- **Multi-Frequency Module (MFM):** The MFM is installed in the 3rd position of the MCP/MP20. This board provides an additional 12 DSP circuits for DTMF tone detection. *This board has been discontinued as of 05/2009. The CRM daughter board is a replacement for this part.*

- **Miscellaneous (MIS):** The MIS is installed in the first position of the MCP/MP20 (towards front of the board). MIS provides 2 external Music On Hold ports, an external paging port, a loud bell port, a common bell port, and also provides 2 dry contact relay ports that connect or disconnects the signal transmission or power supply with external equipment.
- **RCM:** This board has a slide switch to switch between R2 and CID. This switch should always be in the CID position. R2 signaling is not used in the USA. The RCM board installs in the middle position on the MCP/MP20 card. The RCM board is used to provide 14 Caller ID DSP circuits for Caller ID detection on loop start trunks.
- **RCM2:** This board performs the same function as the RCM, analog Caller ID (CID) decoding on incoming calls. In addition, the RCM2 provides CID or FSK signaling on analog ports. Any CID compatible device connected to analog station ports can display CID name and number information as received from the telephone company. This board regenerates CID exactly as the central office sends it.

This RCM2 board can be used in place of the RCM. Use MMC 300 to set CID to SLT "ON" for each analog port that will have CID.

This board has a slide switch to switch between R2 and CID. This switch should always be in the CID position. R2 signaling is not used in the USA. The RCM2 board installs in the middle position of the MCP/MP20 card. The RCM2 board is used to provide 14 Caller ID DSP circuits for Caller ID detection on loop start trunks.

- **MODEM:** The MP20 processor card has a modem slot that supports Samsung's universal modem. The modem installation will be in position 3 of the card. It will leave only position 2 for a CRM, RCM, RCM2 or MFM card. Mount the MODEM on MP20 only as shown below:

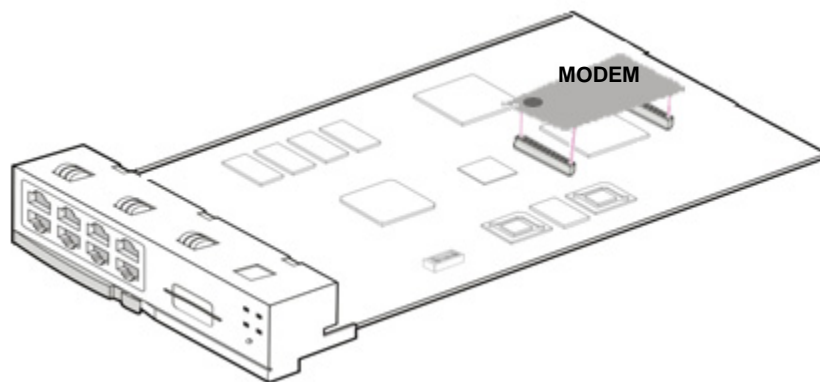

Figure 3.10 Installing Optional Modem Daughtercards on MP20 only

NOTE: When mounting the modem card align the hole on the side of the card with the plastic standoff on the MP20 board to prevent wrong mounting. If you are mounting any other daughterboard in position 3 of the MP20 card, other than the modem, you will need to break off the plastic standoff to avoid blocking and make it a perfect fit.

- CRM: The CRM is supported on the MP20 processor only.** This board performs the same function as the RCM, RCM2, MFM and SCM (the SCM daughter board has been discontinued as of 05/2009. The CRM daughter board is a replacement for this part). The CRM in position 3 can only be set for DTMF tone detection. The CRM in position 2 can be set for CID on FTMF. The board offers 14 CID receiver/transmitter and 16 DTMF receivers. A CRM board located in position 3 will only support DTMF signalling.

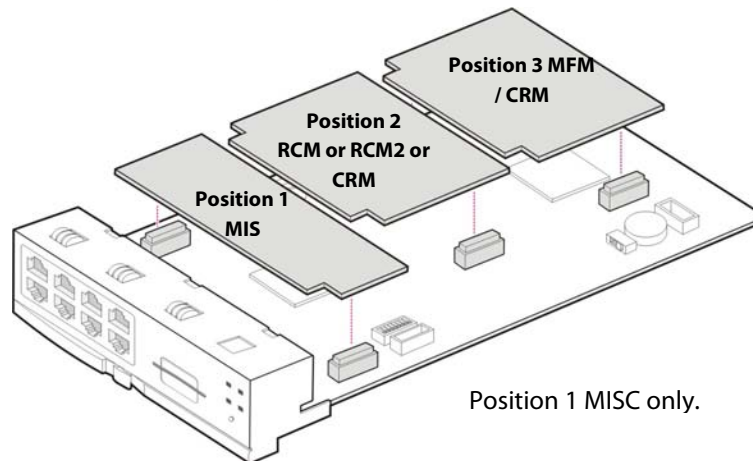

Figure 3.11 Installing Optional Daughterboard on MCP/MP20

3.3 INTERFACE BOARDS

This section describes how to set jumpers and switches of an interface board, how to install optional daughterboards on an interface board, and how to install interface boards into cabinet slots.

3.3.1 Installing Interface Boards

Interface boards may be installed in slot 1 through slot 5 of each cabinet with some restrictions. The following table describes the slot locations for interface board type. The locations of slot 0 through slot 5 of the cabinet are described in [Section 3.1 'Cabinet Configuration'](#).

Table 3.6 Types of Interface Board and Applicable Slots

Category	Interface Board	Applicable Slot
Trunk Cards	TEPRI/TEPRIa	Slot 3 through slot 5 of the main cabinet Slot 3 of the expansion cabinet
	8TRK/8TRK2,16TRK	Slot 1 through slot 5 of the main cabinet Slot 1 through slot 5 of the expansion cabinet

Category	Interface Board	Applicable Slot
Station Cards	8DLI, 8SLI/8SLI2, 16SLI2, 16DLI2, 8COMBO/8COMBO2, 16MWSLI	Slot 1 through slot 5 of the main cabinet Slot 1 through slot 5 of the expansion cabinet
VoIP, Wireless and Data Modules	PLIM/PLIM2	Slot 2 through slot 5 of the main cabinet* Slot 2 through slot 5 of the expansion cabinet*
	4DSL	Slot 1 through slot 5 of the main cabinet Slot 1 through slot 5 of the expansion cabinet
	WIM	Slot 1 of either main cabinet or slot 1 of expansion cabinet. Only one per system.
	GSIMT	Slot 2 through slot 5 of the main cabinet* Slot 2 through slot 5 of the expansion cabinet* One per system.
	GPLIMT	Slot 2 through slot 5 of the main cabinet* Slot 2 through slot 5 of the expansion cabinet* One per system. If two 8 port VPM modules used, use slots 3, 4, or 5 only.
	4WLI, MGI-16/MGI	Slot 1 through slot 5 of the main cabinet Slot 1 through slot 5 of the expansion cabinet
Voice Mail	SVMi-20E	Slot 1 through 5 of main cabinet Slot 1 through 5 of expansion cabinet One per system. IMPORTANT NOTE: If two 8VPMF-E Port modules are installed, use slots 3, 4 or 5 of main cabinet only.

The procedure for installing the interface board to each slot is as follows:

- 1) Check the exterior of the interface board for any damage.
- 2) Align each interface board to the guardrails of the universal slot of the OfficeServ 7200 main cabinet or expansion cabinet, and slide the interface board into the slot.

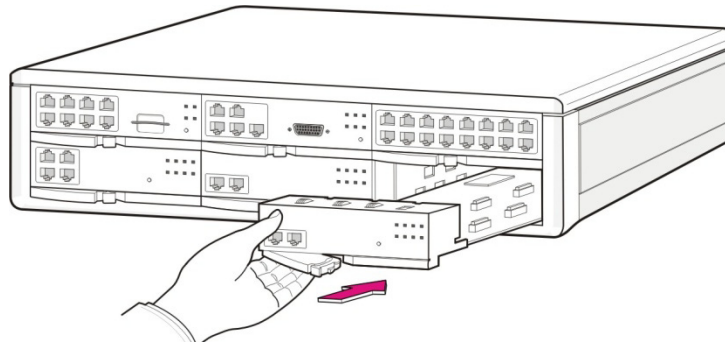

Figure 3.12 Installing Interface Board into Slot

* For PLIM/PLIM2 to operate as a managed switch, it must be installed in slot 2 of either cabinet and a WIM must be installed in slot 1 next to the PLIM/PLIM2.

- 3) Push the front panel lever of the interface board until the board is completely inserted into the OfficeServ 7200 slot.

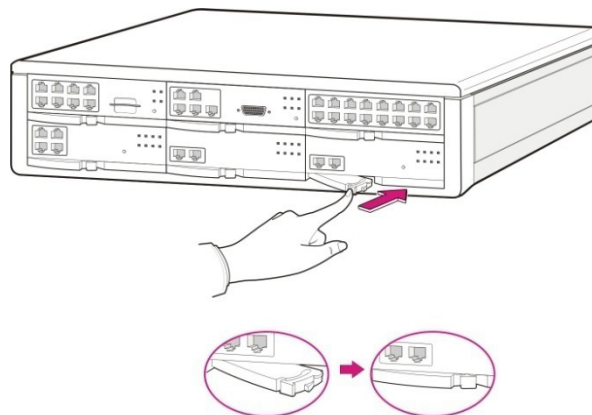



Figure 3.13 Front Panel Lever

3.3.2 Replacing Boards

If the OfficeServ 7200 system fails to operate normally due to an error on the power supply board, control board, or interface board, replace the board with a new one.

 **Removing Cables**
Replace a board after removing all cables connected to the board.

The procedure for replacing a board installed in a slot of a cabinet is as follows:

 **POWER TO THE CABINET MUST BE TURNED OFF.** Failure to do so will damage the card, cabinet and/or corrupt the data moving along the data bus.

- 1) Turn off the power of the cabinet.

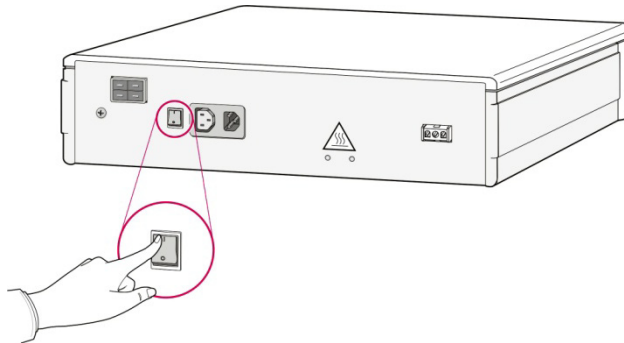

Figure 3.14 Turning the Cabinet Power Off

- 2) When replacing an MCP/MP20 or LCP board, first, remove link cables connecting the MCP/MP20 board to the LCP board. Also, remove all cables connected to the board to be replaced.

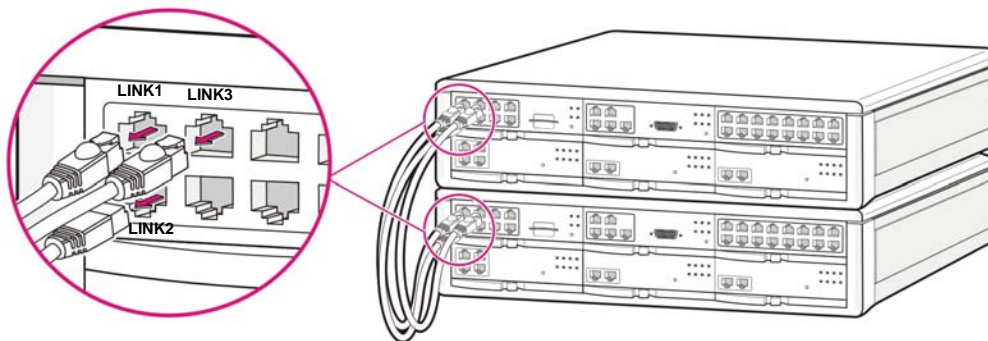

Figure 3.15 Removing Cable

- 3) Pull the lever of the board and pull out the target board slowly.

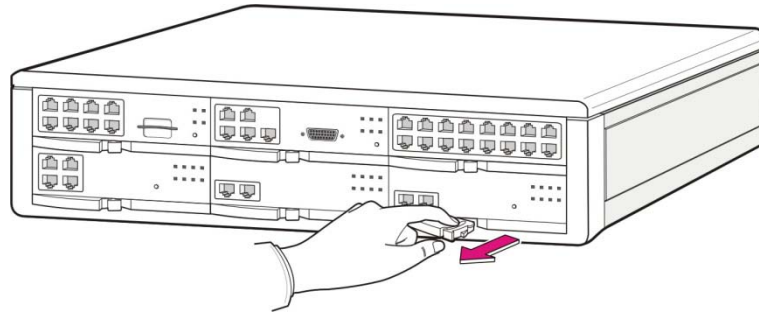

Figure 3.16 Removing Board

- 4) Align the new board to the guardrails of the slot, and slide the new board into the slot. Push the front panel lever of the MCP/MP20 board until it is completely inserted into the OfficeServ 7200 main board port.

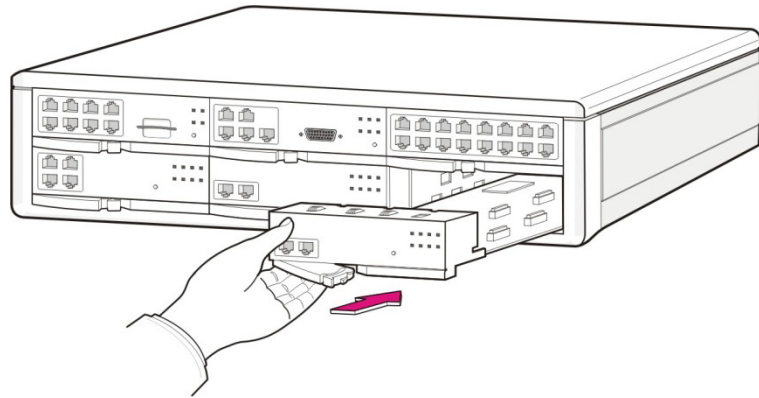

Figure 3.17 Replacing a Board

3.3.3 TEPRI/TEPRIa

The T1E1PRI(TEPRI/TEPRIa) board is a digital trunk interface that supports either T1 or ISDN PRI service. It also supports Q-Sig/PRI signalling required for networking multiple systems.

The TEPRI/TEPRIa board installs in slots 3, 4 or 5 of main cabinet and slot 3 of expansion cabinet. The first four LEDs on the front of the card provide the status of the service (Sync, AIS, Loss and Layer 2 Active states). The second four LED on the front of the card display the type of service. The first TEPRI/TEPRIa card installed in the OfficeServ 7200 is the primary source of external clocking. The second TEPRI/TEPRIa installed is the secondary source of external clocking. Default clock selection is first cabinet, left to right then second cabinet. The clock priority can be changed by using MMC 826. The primary and secondary clock sources should be mounted in the main cabinet to ensure stable reception of clocking from the primary and secondary sources. Regardless of position a CO PRI circuit should always be given clocking priority over T1 circuits. There are two RJ45 modular jacks on the face of the card. The settings for T1 or PRI service are selected by a bank of dip switches as defined below. The PRI supports NI1, NI2, AT&T No. 5 ESS, and DMS 100 offices. A maximum of 4 TEPRI/TEPRIa cards can be provided per system. NOTE: **Do not insert this card with system power ON.**

TEPRI Card Dip Switch

Switch No.	ON	OFF
1	T1	E1
2	PRI	T1
3	NFAS (24B)**	NFAS (23B + D)
4	NETWORK*	USER
5	AFT	NORMAL
6	**	**
7	**	**
8	**	**

TEPRIa Card Dip Switch

Switch No.	ON	OFF
1	T1	E1
2	PRI	T1
3	NFAS (24B)**	NFAS (23B + D)
4	NETWORK*	USER

*If this TEPRI/TEPRIa card is to be the master of a pair of TEPRI/TEPRIa cards that are used to connect two systems together via PRI networking then this DIP switch, DIP switch 4 must be set to ON.

****TEPRI:** Do not change the settings of DIP switches 3, 5, 6, 7, and 8. Switches 3, 5, 6, and 7 must remain OFF and 8 must be ON.

TEPRIa: Do not change the settings of DIP switch 3.

*******The new TEPRIa and TEPRI2 cards have only a four position switch. Set the switches the same as the eight positions using the same first four switches.

[See the S1 switch and jumpers of the TEPRI board as shown on the next page.](#)

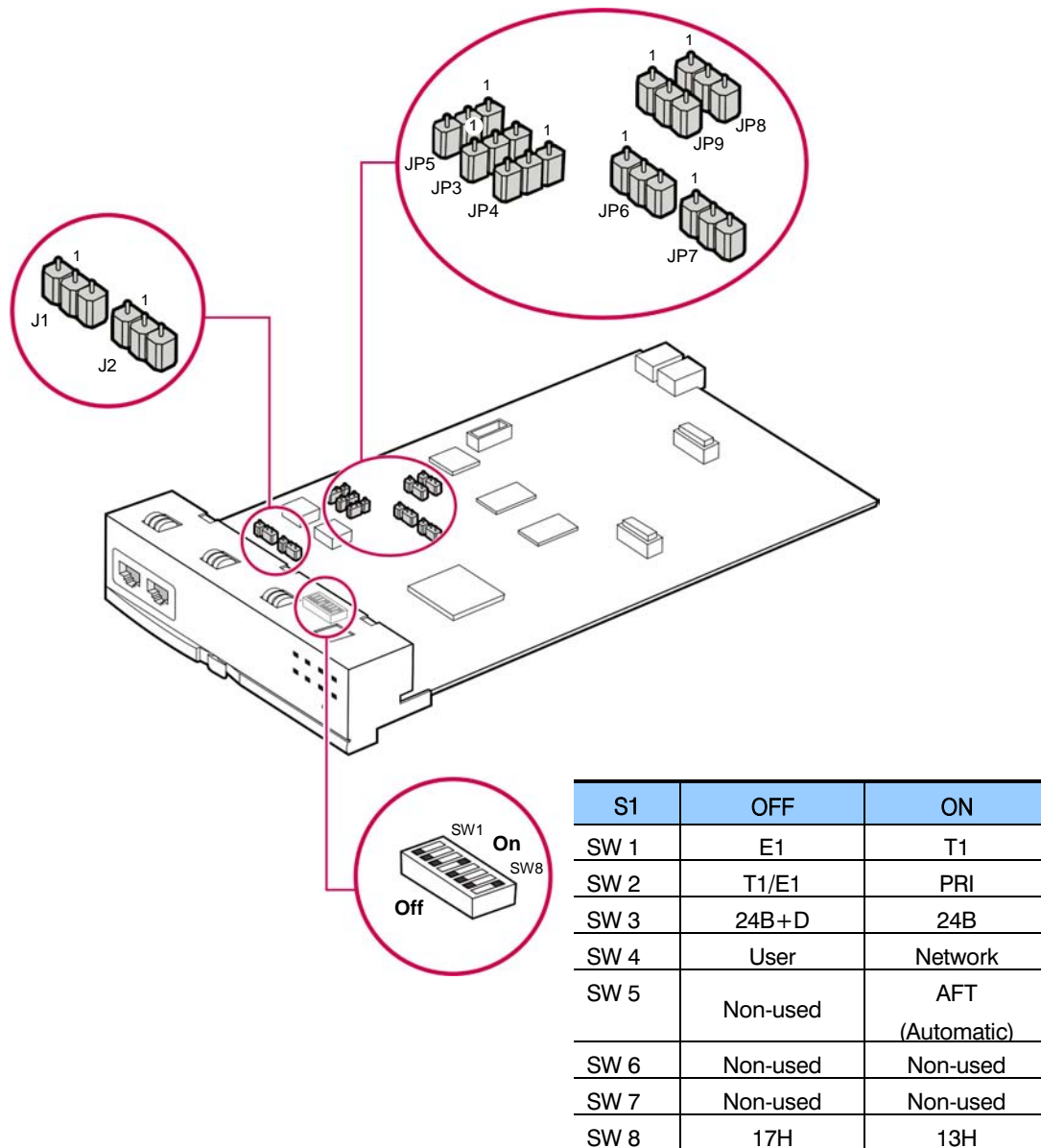
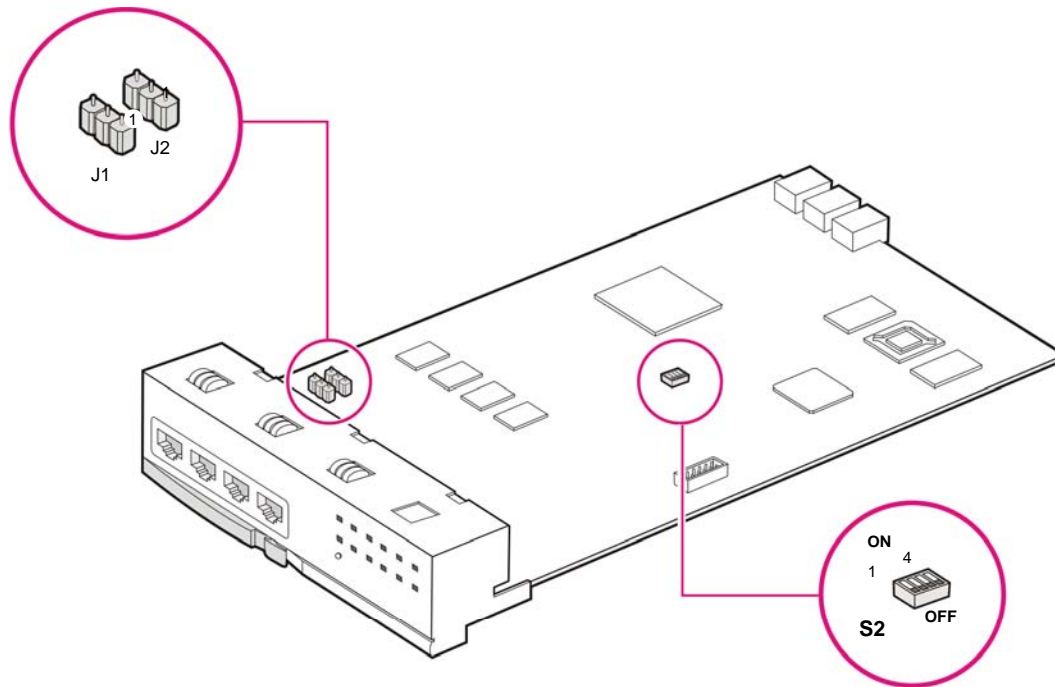

Figure 3.18 Setting Switches on the TEPRI Board



S2	OFF	ON
1	E1	T1
2	T1/E1	PRI
3	24B + D	24B
4	User	Network

Figure 3.19 Setting Switches on the TEPRIa Board

JUMPER SETTING FOR TEPRI

The TEPRI board comes from the factory with the following jumper settings. **These settings should NOT be changed.**

- J1 & J2: Pins 2 & 3 connected
- J3: Pins 2 & 3 connected
- J4~J9: Pins 1 & 2 connected
- Pin 1 is labeled on the board for each jumper.

JUMPER SETTING FOR TEPRIa

The TEPRIa board comes from the factory with the following jumper settings. **These settings should NOT be changed.**

- J1 and J2: Connect #1 and #2 for E1 cable #2 and #3 for T1 cable.

FRONT VIEW OF TEPRI BOARD

The front view of the TEPRI board is shown in the picture below.



Figure 3.20 Front View of the TEPRI

Front panel components of the TEPRI:

Table 3.7 Ports and LEDs of the TEPRI

Ports & LEDs	Function Description
T1/E1/PRI	Ports that connect the T1/E1/PRI cable.
SIO	Serial port (for Samsung Use ONLY)
RST	Button for resetting the TEPRI/TEPRIa board.
SYNC LED	Clock synchronization. - On: Indicates loss of framing (Error Condition). - Off: Clocks are synchronized when they inter-work with the counterpart station (Normal).
LOS LED	This LED indicates loss of signal. - On: Signals have been lost, no PCM clocking is being received. - Off: Signals being received (Normal).
AIS LED	This LED indicates whether the T1/E1 remote alarm has been generated. - On: The remote alarm has been generated. All one's are being received (Error) - Off: The remote alarm has not been generated (Normal).
L2 LED	This LED indicates the operation status of Layer 2. - On: The PRI Layer 2 is operating properly. PRI message is being received. - Off: The PRI Layer 2 is operating abnormally.
IPC LED	This LED indicates the presence of inter-processor messaging. - On: The board is communicating with the MCP/MP20/LCP. - Off: The board is not communicating with the MCP/MP20/LCP.

Ports & LEDs	Function Description
CLK LED	This LED indicates whether this board is a master or slave. - On: The board has received the synchronization clock from the counterpart station. - Off: Using synchronous clock for internal clock.
TP1 LED	This LED indicates whether the T1 is established. - This LED turns on once the T1 is established.
TP2 LED	This LED indicates whether the PRI is connected. - This LED turns on once the PRI is connected.

FRONT VIEW OF TEPRIa BOARD

The front view of the TEPRIa board is shown in the picture below.

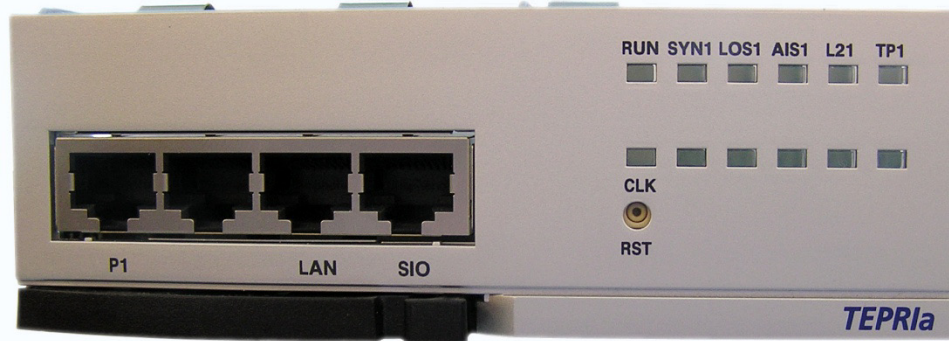

Figure 3.21 Front View of the TEPRIa

Front panel components of the TEPRIa:

Table 3.8 Ports and LEDs of the TEPRIa

Port, LED	Function Description
P1	Port for connecting T1/E1/PRI cables
LAN	Port for connecting to Ethernet (reserved for future use)
SIO	Serial port for internal Samsung engineering use only.
TP1 LED	Indicates the type of the circuit connected to port P1 - On: PRI in operation - Off: T1/E1 in operation
L21 LED	This LED indicates the operation status of Layer 2 - On: The PRI Layer 2 is operating properly. PRI message is being received. - Off: The PRI Layer 2 is operating abnormally.
AIS1 LED	This LED indicates whether the T1/E1 remote alarm has been generated. - On: The remote alarm has been generated. All one's are being received (Error) - Off: The remote alarm has not been generated (Normal).

Port, LED	Function Description
LOS1 LED	This LED indicates loss of signal. - On: Signals have been lost, no PCM clocking is being received. - Off: Signals being received (Normal).
SYN1 LED	Clock synchronization. - On: Indicates loss of framing (Error Condition). - Off: Clocks are synchronized when they inter-work with the counterpart station (Normal).
RUN LED	LED turns ON green: When T1 operates in normal (Blink in the cycle of 200 ms) LED turns ON orange: When E1 operates in normal (Blink in the cycle of 200 ms)
CLK LED	This LED indicates whether this board is a master or slave. - On: The board has received the synchronization clock from the counterpart station. - Off: Using synchronous clock for internal clock.
RST button	Card Reset button

[Refer to Section 6.2.2 for Port Pinout and Wiring.](#)

3.3.4 8TRK

The 8TRK board provides 8 ports for analog trunk lines with Caller ID capabilities. This board can go into any universal slot (1 ~ 5) in any cabinet. Add as many as needed.

FRONT VIEW OF 8TRK

The front view of the 8TRK board is shown in the picture below.

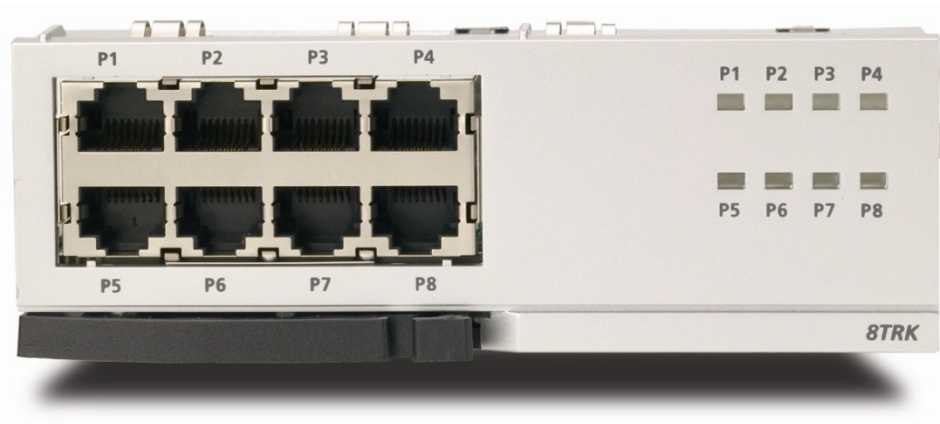

Figure 3.22 Front View of the 8TRK

The components on the front panel of the 8TRK have the functions below:

Table 3.9 Ports and LEDs of the 8TRK

Ports & LEDs	Function Description
P1~P8	Trunk ports.
P1~P8 LED	These LEDs indicate the status of the ports. - Off: The trunk line is not being used. - On: The trunk line is being used. - Blink: Incoming call ringing on trunk.

[Refer to Section 6.2.1 for Port Pinout and Wiring.](#)

3.3.5 8TRK2

There are no LEDs on this board compared to the 8TRK card.

FRONT VIEW OF 8TRK2 BOARD

The front view of the 8TRK2 board is shown in the picture below.

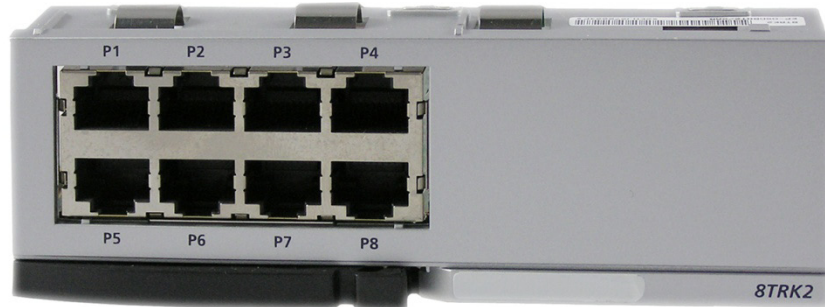

Figure 3.23 Front View of the 8TRK2

3.3.6 16TRK

This card contains sixteen loop start C.O. line interface circuits with C.O. disconnect detection. It also contains the circuitry needed for Caller ID. It can be inserted in any universal slot in either cabinet.

FRONT VIEW OF 16TRK

The front view of the 16TRK board is shown in the picture below.

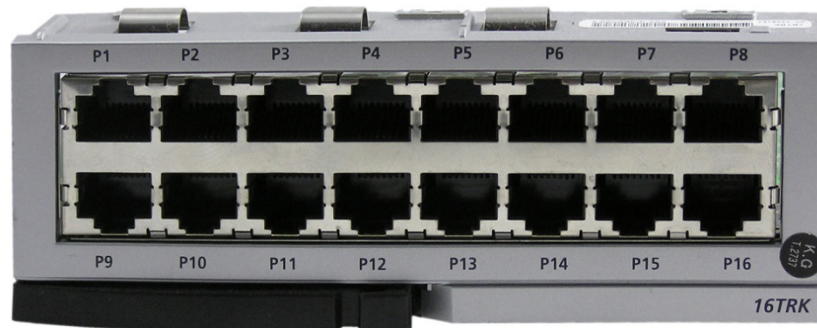

Figure 3.24 Front View of the 16TRK

The components on the front panel of the 16TRK have the functions below:

Table 3.10 Ports and LEDs of the 16TRK

Ports & LEDs	Function Description
P1~P16	Trunk ports.
LED	There are no LEDs on this card.

3.3.7 16DLI2

This board provides 16 ports for connecting Samsung Digital Keysets. Each port provides 1B+D. This means only one station/one voice channel per port. This board can go into slots 1 through 5 of either cabinet. Add as many as needed.

FRONT VIEW OF 16DLI2

The front view of the 16DLI2 board is shown in the picture below.

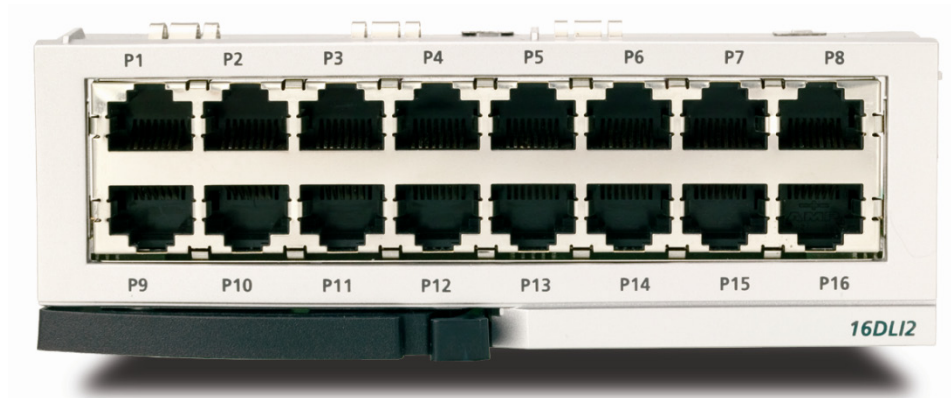

Figure 3.25 Front View of the 16DLI2

16DLI2 front panel components:

Table 3.11 Ports of the 16DLI2

Ports	Function Description
P1~P16	Samsung Digital Telephone Extension Port

NOTE: A station using KDB-D or KDB-S cannot connect to a port on this board.

[Refer to Section 7.1.3 \(Connecting a Digital Phone\) for port Pinout and Wiring.](#)

3.3.8 8DLI

This board provides 8 ports for connecting Samsung Digital Keysets. This board can go into slots 1~5 of either cabinet. Add as many as needed.

SPECIFICATIONS

The specifications of the 8DLI/16DLI board are as follows:

- 8 station ports 2B+D (two voice channels and one signal channel) per port.
- Stations using KDB-D or KDBS adapters can connect to this board.

FRONT VIEW OF 8DLI

The front view of the 8DLI board is shown in the picture below.

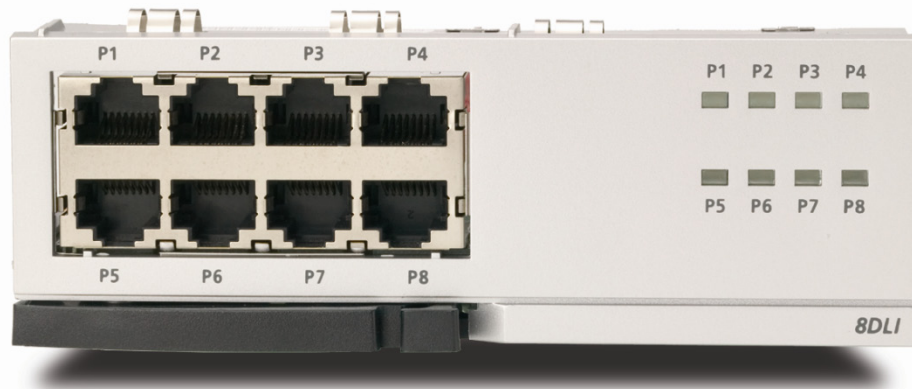

Figure 3.26 Front View of the 8DLI

Front panel components of the 8DLI board have the functions below:

Table 3.12 Ports and LEDs of the 8DLI

Ports	Function Description
P1~P8	Station ports of Samsung Digital Phones.
P1~P8 LED	These LEDs indicate the status of the ports. - Off: The station is not being used. - On: The station is being used.

[Refer to Section 7.1.3 for Port Pinout and Wiring.](#)

3.3.9 8COMBO/8COMBO2

These boards provide 8 ports for connecting analog stations and 8 ports for connecting Samsung Digital Keysets. These boards can go into slots 1 through 5 in either cabinet. Add as many as needed.

FRONT VIEW OF 8COMBO/8COMBO2

The front view of the 8COMBO and 8COMBO2 boards are shown in the picture below.

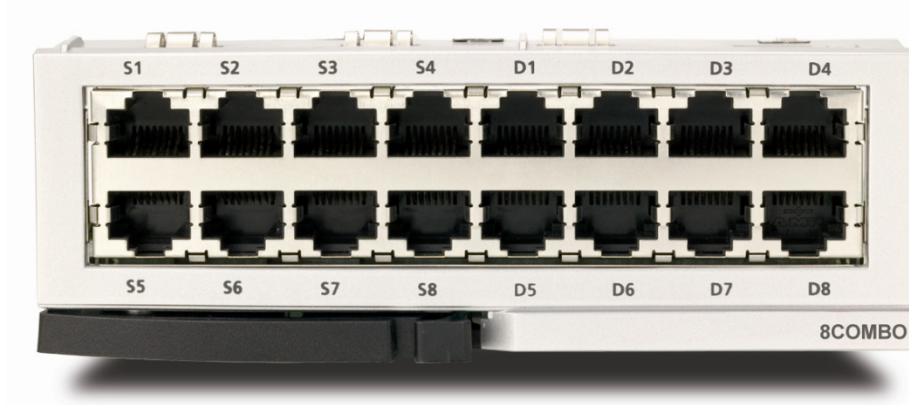

Figure 3.27 Front View of the 8COMBO

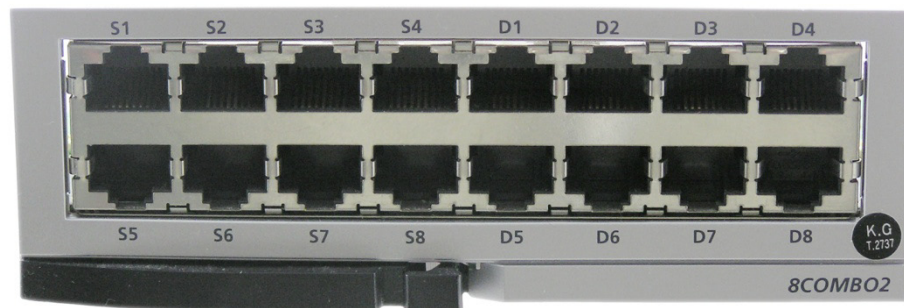

Figure 3.28 Front View of the 8COMBO2

- Ports S1~S8 are for analog stations only.
- Ports D1~D8 are for Samsung Digital Stations only.

[See Sections 7.1.2 and 7.1.3 for port Pinout/wiring.](#)

3.3.10 16SLI2/16MWSLI

These boards provide 16 ports for connecting analog stations. It can go into slots 1 through 5 in either cabinet. Add as many as needed. These cards automatically detect DTMF or dial pulse signals from the SLT. These cards have no DTMF receiver. They will share the system resources. If there is a high concentration of SLI cards, and MFM daughter board must be added to relieve congestion. MFM can be added to the MCP/MP20.

FRONT VIEW OF 16SLI2/16MWSLI

The front view of the 16SLI2 and 16MWSLI boards are shown in the pictures below.

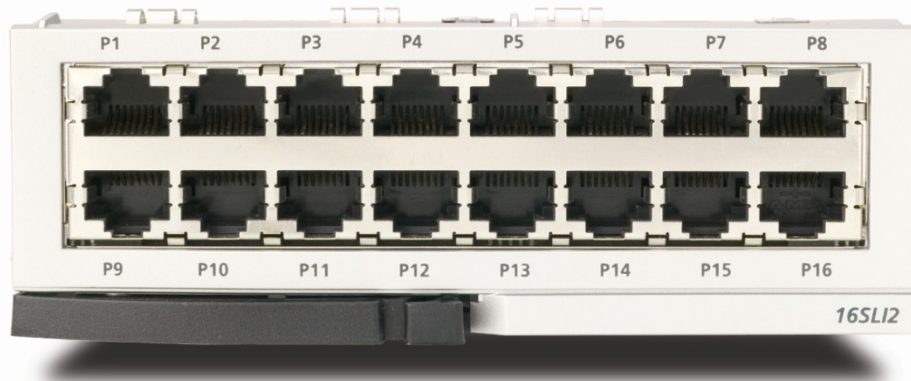

Figure 3.29 Front View of the 16SLI2

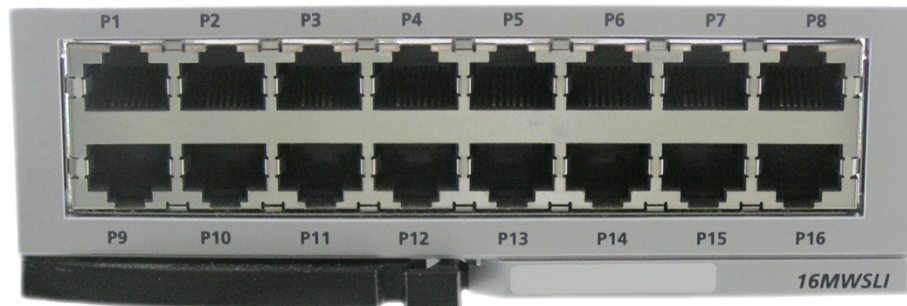

Figure 3.30 Front View of the 16MWSLI

Front panel components of the 16SLI2/16MWSLI:

Table 3.13 16SLI2/16MWSLI Board Ports

Ports & LEDs	Function Description
P1~P16	Analog Extension Ports

- The 16MWSLI supports Message Waiting Lamp functionality for analog stations that have this capability.
- Port 1 supports Power Failure Transfer function ([Refer to Section 3.4](#)).

- [See Section 7.1.2 for port Pinout/Wiring.](#)
- Do not connect devices with a total REN greater than 5.0 to this card.

3.3.11 8SLI/8SLI2

This board provides 8 ports for connecting analog stations. It can go into slots 1 through 5 of either the main or the expansion cabinet. Add as many as needed. This card automatically detects DTMF or dial pulse signals from SLT. This card does not have any DTMF receivers; it uses system resources. If there is a high concentration of SLI boards, an MFM daughter board must be added to the MCP/MP20 to relieve congestion.

FRONT VIEW OF 8SLI/8SLI2

The front view of the 8SLI and 8SLI2 boards are shown in the pictures below.

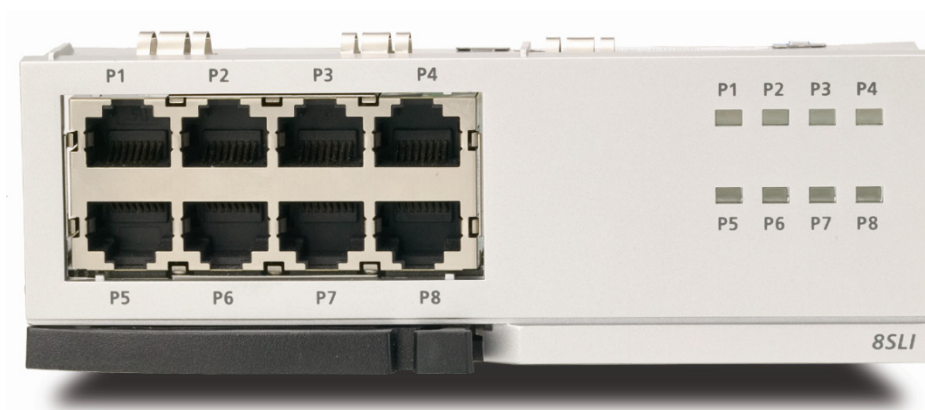

Figure 3.31 Front View of the 8SLI

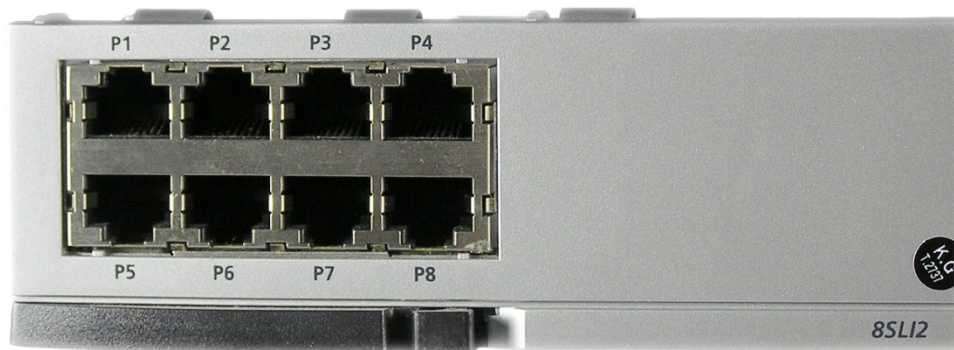

Figure 3.32 Front View of the 8SLI2

Front panel components of the 8SLI/8SLI2:

Table 3.14 Ports and LEDs of the 8SLI/8SLI2

Ports & LEDs	Function Description
P1~P8	Station ports for analog phones.
P1~P8 LED	These LEDs indicate the operation status of the ports. - Off: The station is not active on a call. - On: The station is active on a call.

- Port 1 (P1) supports Power Failure Transfer function ([Refer to Section 3.4](#)).
- [See Section 7.1.2 for port Pinout/Wiring](#).
- Do not connect devices with a total REN greater than 5.0 to this card.

3.3.12 WIM (WAN INTERFACE MODULE)

This board provides data router functionality to the OfficeServ 7200. It offers a variety of interfaces for connecting to external and internal data networks.

A WIM can be installed in either slot 1 of the main cabinet or slot 1 of the expansion cabinet. Only ONE WIM board can be installed per system.

If a PLIM (PoE LAN Interface Module) needs to be a managed switch via the OfficeServ 7200 backplane (Method 2), then it must be installed in slot 2, right next to the WIM which is in slot 1. PLIM management can also be accomplished using an Ethernet cable (Method 1).

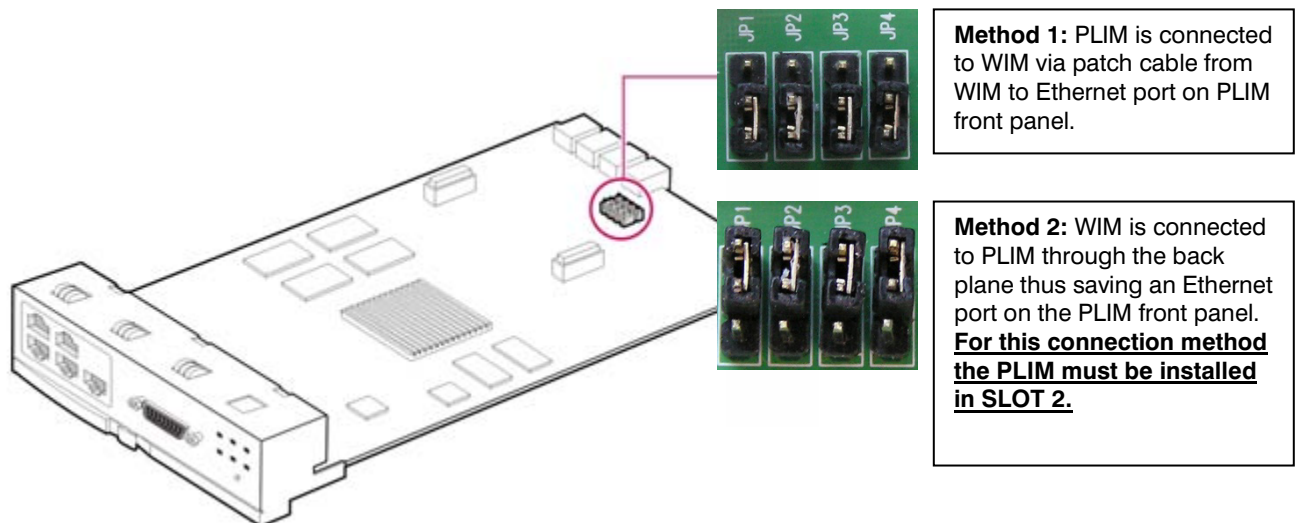

Figure 3.33 Jumper Setting of WIM Board

[Refer to the OfficeServ 7200 Data Server User Manual for WIM Configuration and Management Information.](#)

FRONT VIEW OF WIM

The front view of the WIM module is shown in the picture below.



Figure 3.34 Front View of the WIM Board

The components on the front panel of the WIM have the functions below.

Table 3.15 Ports and LEDs of the WIM

Ports & LEDs	Function Description
P1, P2 & P3	10/100 Base-T Ethernet Interface Ports that may be set for LAN or WAN.
P4	10 Base-T Ethernet Interface Port that may be set for LAN or WAN.
SERIAL	Port that connects to a dedicated serial line that may be set to LAN or WAN. The V.35 cable can be ordered separately (See Figure 3.34 for pin outs).
SIO	Serial Console Access
RST	Button for resetting the WIM module
RUN LED	This LED indicates the operation status of the WIM. - Off: The WIM board is in an abnormal status or the power is not being supplied. - On: The WIM is operating properly.
P1, P2, P3, P4 and LED	These LEDs indicate the operational status of the Ethernet Port. - Off: The link is connected. - On: The link is not connected. - Flashing: Data is being transmitted or received.
SERIAL LED	This LED indicates the operation status of V.35 connection. - Off: The link is not connected to a network using this interface. - On: The link is connected to a WAN or LAN.
LAN LED	This LED indicates the Operation Status of the LAN - Off: Link is not connected to LAN. - On: Link is in connected to LAN.

Refer to Figure 3.34 for SIO cable pin outs.

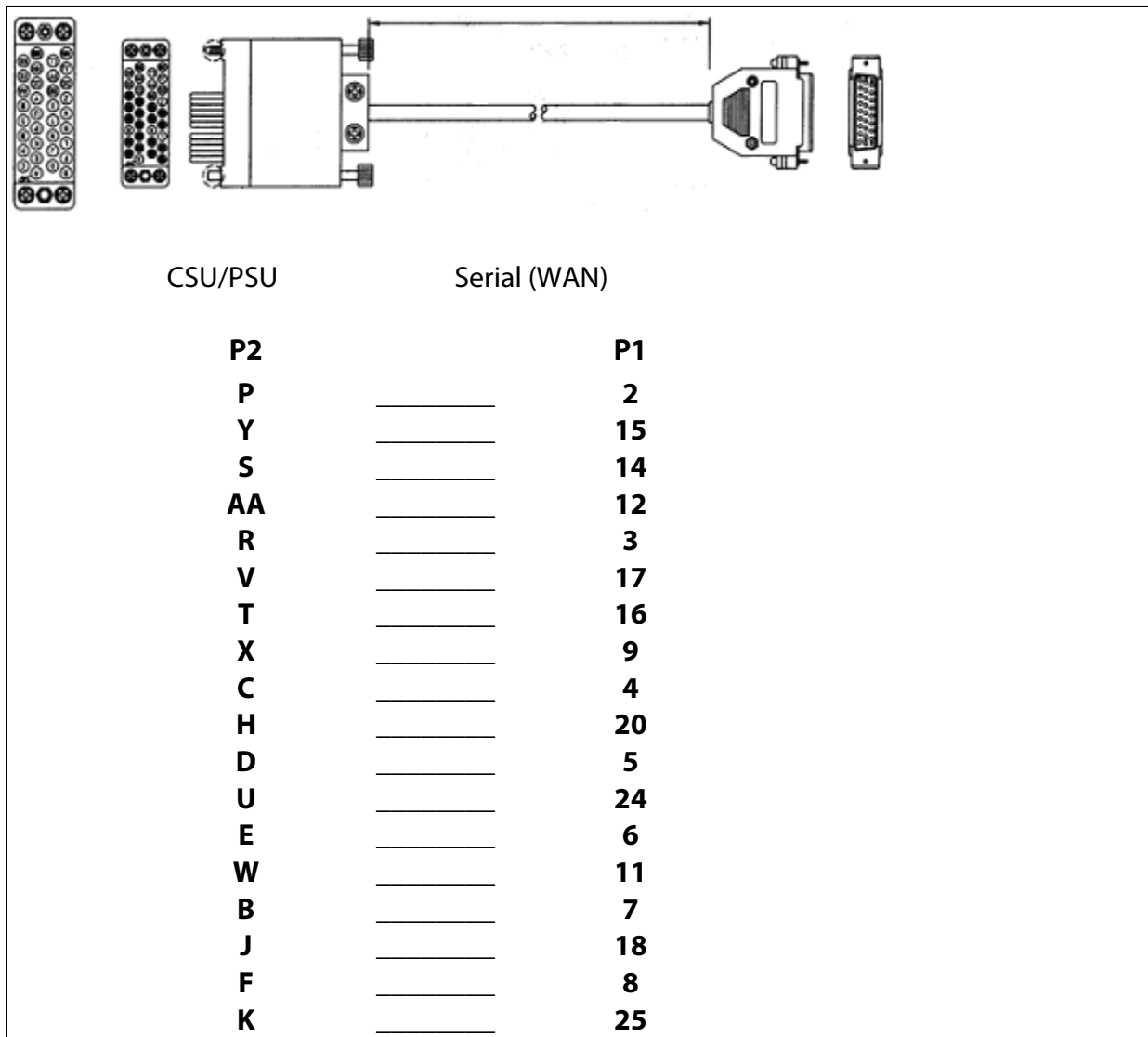

Figure 3.35 V.35 Cable Pin Outs.

This cable connects from the "Serial" connector or the WAN card to the customer provided CSU/DSU. This cable can be ordered separately.

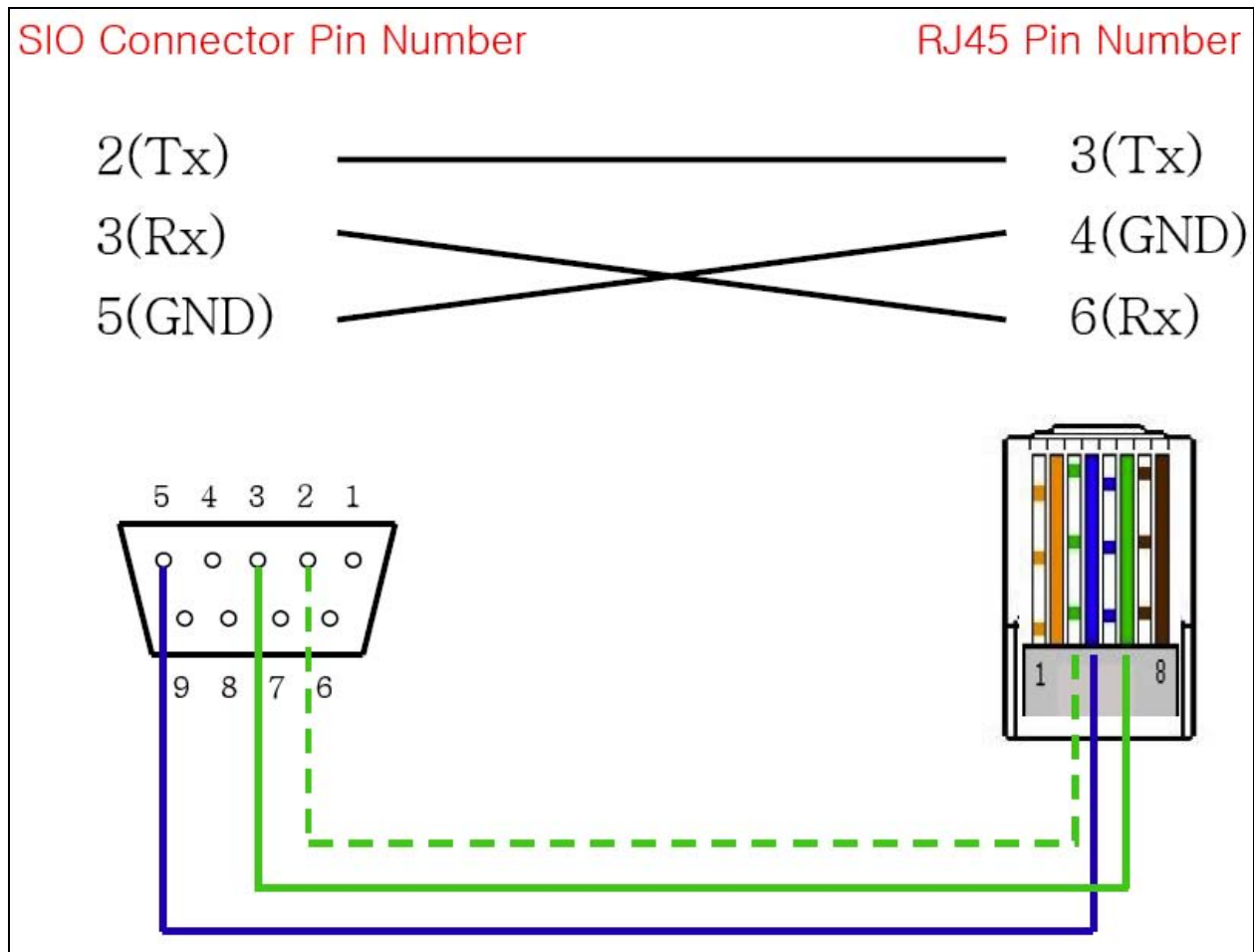

Figure 3.36 SIO Connector, RJ45 Pin Assignment

3.3.13 PLIM (PoE LAN INTERFACE MODULE)

The PLIM sends/receives data to/from the internal LAN, and provides 16 ports of 10/100 Base-T Ethernet interfaces. It functions as a Layer 2 LAN switch. The PLIM can connect with the WIM through the internal back panel if it is in slot 2 and the WIM is in slot 1 with appropriate jumper settings. The PLIM supports Power over Ethernet (IEEE 802.3af). This means that it can provide power to any IEEE 802.3af compliant device that is connected to any of its Ethernet ports. All Samsung ITP/SMT-i phones and SMT-R2000 Dual-Band APs can receive power when connected to PLIM. When connected to the PLIM Ethernet port, these devices no longer need the AC power adapter.

The PLIM can be installed in slots 2 through 5 of any cabinet. However, for the PLIM to be a managed switch, it must be installed in slot 2 with a WIM in slot 1. A maximum of 8 PLIM/PLIM2s can be added however only one PLIM per system can be a “managed” switch.

When a PLIM acts as an unmanaged switch, it simply performs as a simple data switch (10/100 Base-T). When it is managed (by WIM), advanced features such as Layer 2 QoS, 802.1q (VLAN), IGMP snooping, and much more are available. For it to be managed by the WIM, it must be

connected to the WIM using one of the 2 methods described in the previous section ([see Section 3.3.10](#)).

PLEASE NOTE:

The PLIM/PLIM2 module uses the -48V rail from the OS7200 power supply to provide power to connected devices over Ethernet. The OS7200 power supply provides up to 2200mA of output current. **PER EACH OS7200 CABINET (not per system), the SUM of all current drawn from 1) devices powered by PLIM cards, 2) digital key sets connected to DLI ports 3) analog devices connected to SLI ports and 4) COMBO WBS24 AP's connected to 4WLI cards cannot exceed 2200mA.** The chart below provides current ratings for various devices connected to the system:

Card Name	Connected Device Type	Current Consumption per Each Device (mA)
DLI	Digital Keypad	25
MWSLI	Analog Phone	25
	Analog Phone with Message Waiting Lamp	30
PLIM/PLIM2 (48 V)	ITP-5121D or ITP-5107S	100
	ITP-5112L	130
	SMT-R2000 Dual AP	200
	SMT-i3105	83
	SMT-i5210	127
	SMT-i5220, SMT-i5230	107
	SMT-i5243	156
	SMT-i5264	100
	A52GE Gigabit	56
	Other IEEE 802.3af compliant device.	See manufacture current draw specifications

IF ADDING PLIM/PLIM2 CONNECTED DEVICES CAUSES THE TOTAL CURRENT DRAWN TO EXCEED 2200mA PER CABINET (not per system), THEN YOU MUST CONNECT THE OS7150 EXTERNAL PoE POWER SUPPLY MODULE to the cabinet. This unit will provide additional power only to devices connected to PLIM/PLIM2s, when the OS7200 power supply limits have been exceeded. Please refer to [Section 5.3, CONNECTING THE OS7150 EXTERNAL PoE PSU SUPPLEMENTAL POWER SUPPLY](#) for further information.

[Refer to the OfficeServ 7200 Data Server Manual for detailed PLIM installation and configuration information.](#)

It is important to note that the OS7150 only provides additional power to the PLIM/PLIM2. The OS7150 is used when the PLIM/PLIM2 connected devices causes the total current draw per cabinet to exceed 2200mA. It does **not** provide power to DLI, MWSLI and 4WLI ports.

SPECIFICATIONS

The PLIM data board provides 16 ports of 10/100 Base-T.

FRONT VIEW OF PLIM

The front view of the PLIM module is shown in the picture below.

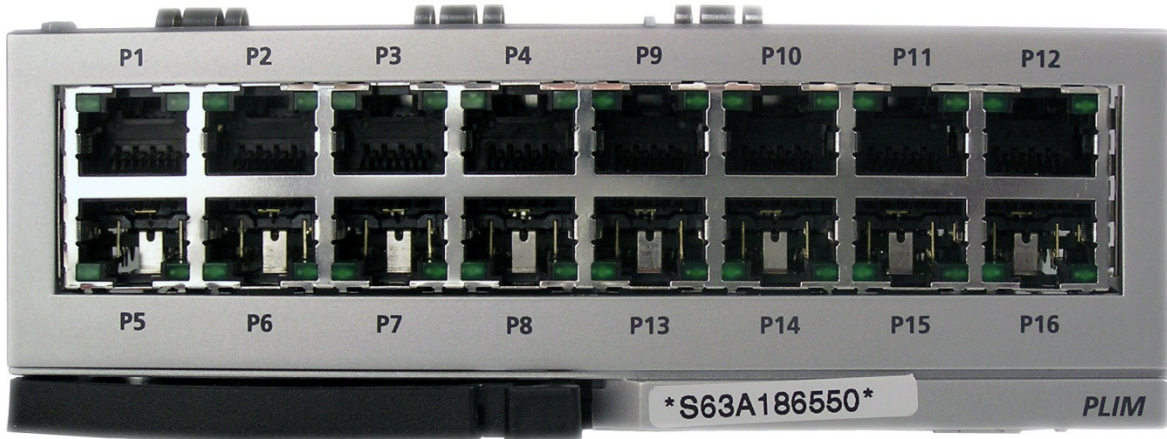

Figure 3.37 Front View of the PLIM

The front panel components of the PLIM have the functions below:

Table 3.16 Ports and LEDs of the PLIM

Ports & LEDs	Function Description
P1~P16	RJ-45 (10/100 Base-T) LAN ports (Full Duplex).
Left LED of each port	The LED ON indicates if the link is operating. - Blink: The link is transmitting/receiving data packets.
Right LED of each port	The LED indicates if the port of 10 Base-T/100 Base-Tx is operating. - Off: The port is operating as 10 Base-T port. - On: The port is operating as 100 Base-T port.

3.3.14 PLIM2 (PoE LAN INTERFACE MODULE)

PoE LAN Interface Module (PLIM2) can use Power Supply Unit (PSU) or an external rectifier and selects the power supply source by using shunt pins.

FRONT VIEW OF PLIM2 BOARD

The front view of the PLIM2 data module is shown in the picture below.

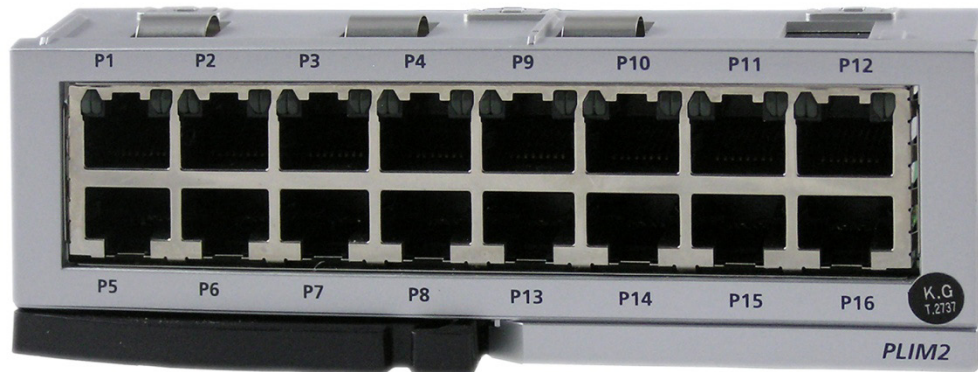

Figure 3.38 Front View of the PLIM2 Board

The front panel components of the PLIM2 have the functions below:

Table 3.17 Ports and LEDs of the PLIM2

Ports & LEDs	Function Description
P1~P16	RJ-45 (10/100 Base-T) LAN ports (Full Duplex).
Left LED of each port	The LED ON indicates if the link is operating. - Blink: The link is transmitting/receiving data packets.
Right LED of each port	The LED indicates if the port of 10 Base-T/100 Base-Tx is operating. - Off: The port is operating as 10 Base-T port. - On: The port is operating as 100 Base-T port.

JUMPER SETTINGS

- When using the internal rectifier the shunt pins (J2, J3 and J4) are connected between pin 1 and pin 2. Since the available capacity is limited to PSU, the use of ports is limited to 16 ports and the use of digital phones is, also, limited. (For more information on the limitation about the use of digital phone phones in accordance with the use of PLIM2 port, contact your dealer.)
- For the use of an external rectifier: The shunt pins (J2, J3 and J4) are connected between pin 2 and pin 3. There is no restriction on the use of an external rectifier because each of them can supply the current of 10 A. Limit each current running through PLIM2 ports below 0.1A and in the module below 1.6 A.

Each jumper is numbered in ascending order from the marked '1' in the following figure.

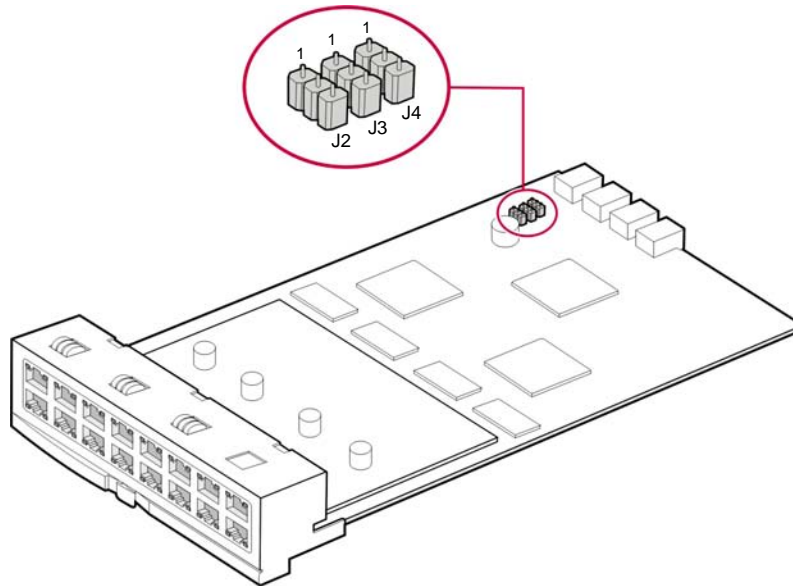

Figure 3.39 Setting the Jumpers of PLIM2 Board

3.3.15 GPLIMIT

The Gigabit PoE LAN Interface Module TX (GPLIMIT) board provides data transmission through the intranet. Compared to the PLIM, the GPLIMIT board comes with an additional GbE interface and can provide 12 10/100 BASE-T interface ports and 2 1000 BASE-TX ports. The GPLIMIT board provides a simple switching hub function. Only one GPLIMIT may be installed per cabinet.

Major Functions

The major functions of the GPLIMIT data board are as follows.

- L2 Ethernet Switching
- 10/100 BASE Full/Half duplex auto-sensing
- VLAN Networking (802.1q)
- Packet Priority Control (802.1p)
- Flow Control (802.3x)
- Multi-Casting (IGMP Snooping)
- IEEE 802.3af PoE (Power over Ethernet)

Specification

The specification of the GPLIMT data board is as follows.

- 12 10/100 Base-T interface port
- 2 10/100/1000 Base-TX interface port
- 1 Serial console port (also used as P12)

FRONT VIEW OF THE GPLIMT

The front view of the GPLIMT data board is shown in the picture below.

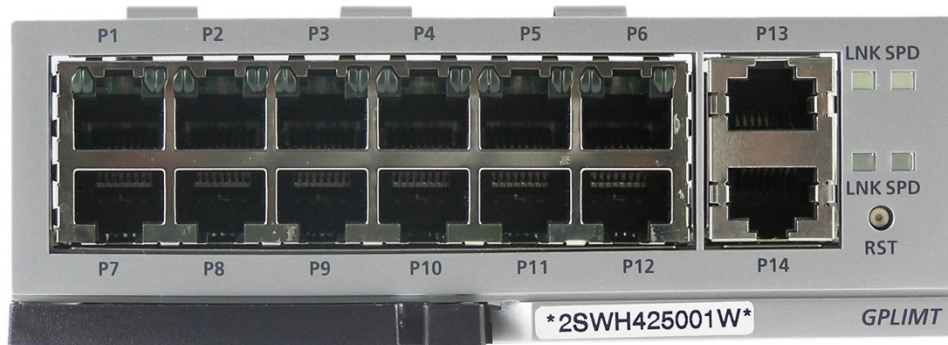

Figure 3.40 Front View of the GPLIMT

The components on the front panel of the GPLIMT board have the functions below:

Table 3.18 Ports and LEDs of the GPLIMT

Ports & LEDs	Function Description
P1~P12	Ports that connect to the 10/100 Base-T Ethernet
P13, P14	Ports that connect to the 10/100/1000 Base-TX GbE (Gigabit Ethernet)
Left LED of P1~P6	First LED: Indicates if the P1~P6's link is operating - On: When the link is operating, LED is turned on into green color - Blink: When each port is active, the LED is blinking Second LED: Indicates whether the P1~P6 are operating in 10/100 Base-T mode - Off: In operation as 10 Base-T - On: In operation as 100 Base-TX

Ports & LEDs	Function Description
Right LED of P1~P6	First LED: Indicates if the P7~P12's link is operating - On: When the link is operating, LED is turned on into green color - Blink: When each port is active, the LED is blinking Second LED: Indicates whether the P7~P12 are operating in 10/100 Base-T mode - Off: In operation as 10 Base-T - On: In operation as 100 Base-TX
LNK LED	- Turns on if the Giga port P13~P14's link is connected. - Blinks if the corresponding ports are active.
SPD LED	Indicates whether the Giga ports P13~P14 are operating in 10/100/1000 BASE-T mode - Off: In operation as 10 Base-T - On: In operation as 100 Base-TX - Blink: The ports are operating in 1000 Base-TX mode
RST	Button for resetting the GPLIMIT board

3.3.16 GSIMT

The Gigabit Switch Interface Module TX (GSIMT) provides Layer 2 and Layer 3 Gigabit LAN interfaces to support the data network. Only one GSIMT may be installed per cabinet.

Major Functions

The major functions of the GSIMT data board are as follows.

- L3 Unicasting Protocol
- L3 Multicasting Protocol
- Ethernet Switch (802.3 compatible)
- 10/100/1000 Base-TX port
- Packet Priority Control (802.1p)
- VLAN Networking (802.1q)
- Spanning Tree Protocol (RSTP, PVST+)
- Diffserv
- Flow Control (802.3x)
- Multi-Casting (IGMPv1/v2, DVMRP, PIM-SM)

Specification

The specification of the GSIMT data board is as follows. 12 10/100/1000 Base-TX interface ports

FRONT VIEW OF THE GSIMT BOARD

The front view of the GSIMT data board is shown in the figure below.



Figure 3.41 Front View of the GSIMT

The components on the front panel of the GSIMT board have the functions below:

Table 3.19 Ports and LEDs of the GSIMT

Ports & LEDs	Function Description
P1~P12	Ports that connect to the 10/100/1000 Base-TX GbE (Gigabit Ethernet)
SIO	Port that connects to the RS-232
DBL	Port that connects to the LAN for debugging purpose
Left LED of P1~P6	Indicates whether the P1~P6 are operating in 10/100/1000 BASE-TX mode - Alternates between green and orange: In operation as 10 Base-T - Green Light: In operation as 100 Base-TX (blinks if active) - Orange Light : In operation as 1000 Base-TX (blinks if active)
Right LED of P1~P6	Indicates whether the P7~P12 are operating in 10/100/1000 Base-TX mode - Alternates between green and orange: In operation as 10 Base-T - Green Light: In operation as 100 Base-TX (blinks if active) - Orange Light: In operation as 1000 Base-TX (blinks if active)
PWR LED	Power Supply Status - On: The power is being supplied normally
RUN LED	GSIMT Operation Status - Blinking: The RAM programming is running

Ports & LEDs	Function Description
LNK LED	Turns on if the DBL port link is connected
SPD LED	Indicates whether the DBL port is operating in 10/100 Base-T Ethernet mode - Off: In operation as 10 BaseE-T - On: In operation as 100 Base-TX (blinks if active)

3.3.17 MGI (MEDIA GATEWAY INTERFACE)

The MGI board provides a variety of Voice over IP (VoIP) services for the OfficeServ 7200. This card is required for ITP/SMT-i phones, IP networking, IP trunking, SIP trunking and stations or any application that require VoIP.

- **MGI has 0 voice channels.** The MGI-D daughterboard must be added to the MGI for voice communications.
- Up to 4 MGI-D daughterboards can be added to an MGI board.
- Each daughterboard provides 4 voice channels. One MGI with 4 MGI-Ds installed can provide a maximum of 16 voice channels.
- The MGI can go into slots 1 through 5 of either cabinet. Add as many MGIs as needed.

Align the connector of the MGI board to the connector of the optional board (MGI-D) and press the optional board downward. Up to four optional boards can be mounted per MGI.

NOTE: Always install daughterboards starting from the back of the MGI (position 1). **DO NOT SKIP** a position when adding daughter cards. (For example: The first MGI-D goes in position 1, second MGI-D goes in position 2 and so on, working towards the front of the card).

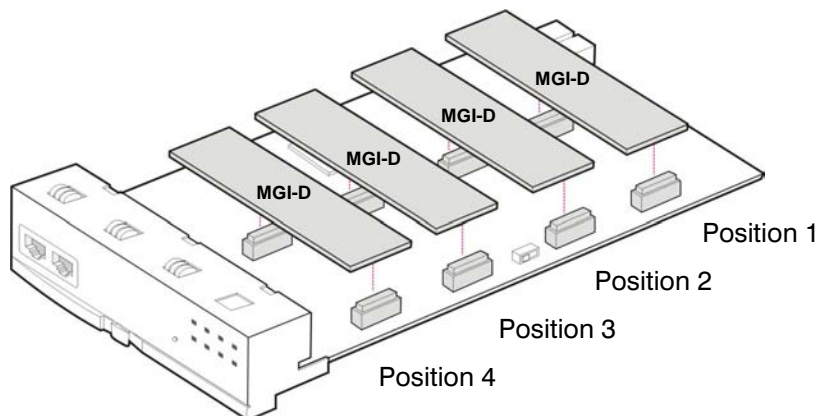

Figure 3.42 Mounting Optional Board on MGI Board

FRONT VIEW OF MGI BOARD

The front view of the MGI board is shown in the picture below.



Figure 3.43 Front View of the MGI Board

MGI-16 (MEDIA GATEWAY INTERFACE)

The MGI-16 board provides a variety of Voice over IP (VoIP) services for the OfficeServ 7200. This card is required for ITP/SMT-i phones, IP networking, IP trunking or any application that require VoIP.

The MGI-16 provides 16 VoIP channels and NO daughterboards are required.

The MGI-16 can be installed into slots 1~5 of either cabinet. Add as many as you require.

FRONT VIEW OF MGI-16 BOARD

The front view of the MGI-16 board is shown in the picture below.



Figure 3.44 Front View of the MGI-16 Board

The components on the front panel of the MGI-16 have the functions below:

Table 3.20 Ports and LEDs of the MGI-16

Ports & LEDs	Function Description
LAN	Port that connects the Ethernet.
SIO	Serial Port (for Samsung Use ONLY)
RST	Button for resetting the MGI/MGI-16.
PWR LED	This LED indicates the power supply status. - Off: Power is not being supplied. - On: Power is being supplied properly.
RUN LED	This LED indicates MCP/MP20 status. - Off: Power is not being supplied. - On: Booting. - Blink: The RAM program is operating.
LAN Tx LED	This LED indicates the transmit status of the LAN port. - Off: Data is not being transmitted. - On or blink: Data is being transmitted.
LAN Rx LED	This LED indicates the receive status of the LAN port. - Off: Data is not being received. - On or blink: Data is being received.
SVC LED	This LED indicates if the service is being offered. - This LED blinks when program is being modified or configuration is being loaded.
DSP LED	This LED indicates if the VoIP DSP is operating. - This LED blinks when the VoIP channels are engaged.
RTPT LED	This LED indicates if the voice packets are being forwarded. - This LED turns on when the voice packets are forwarded.
RTPR LED	This LED indicates if the voice packets are being received. - This LED turns on when the voice packets are received.

3.3.18 OAS (OPTIONAL APPLICATION SERVICES)

The OAS card is a 64 DSP Optional Application Services card. It contains 64 configurable DSP's that can be used as MGI channels, MOBEX DTMF receivers (listed as MOBEX DSP in MMC 850) used by the Executive MOBEX feature, or a mix of both (determined by MMC 858). MGI channels are enabled in 4 port increments, and each increment will decrease the number of MOBEX DSP's as shown in the chart below.

OPTION	16 TIMESLOTS	32 TIMESLOTS	64 TIMESLOTS
0	MOBEX:16 ONLY	MOBEX:32 ONLY	MOBEX:64 ONLY
1	MGI:04+MOBEX:12	MGI:04+MOBEX:28	MGI:04+MOBEX:48
2	MGI:08+MOBEX:08	MGI:08+MOBEX:24	MGI:08+MOBEX:32
3	MGI:12+MOBEX:04	MGI:12+MOBEX:16	MGI:12+MOBEX:16
4	MGI:16 ONLY	MGI:16 ONLY	MGI:16 ONLY

In addition to these configurable DSP's the OAS card has dedicated DSP's used to provide 64 Media Proxy Service (MPS) channels. MPS channels allow IP phones to talk to IP trunks without the use of an MGI. The settings for these MPS channels are found in MMC 843 after setting MPS SERVICE to ON in MMC 861.

SPECIFICATIONS

- The OAS can be installed in any universal slot. When installed in slots 1 or 2 of the main cabinet or slots 1, 2, 4 or 5 of the expansion cabinet only 16 timeslots are available to the OAS card, so a maximum of 16 MOBEX DTMF receivers per card is possible. All other slots allow up to 32 MOBEX receivers per card.
- Up to 5 OAS cards can be installed in the OfficeServ 7200.
- When installed in a 16 timeslot position, the following card slot must be empty.



Figure 3.45 Front View of the OAS

Table 3.21 OAS Front Panel Components

Ports & LEDs	Function Description
LAN	Port that connects the Ethernet.
SIO	Serial Port (for Samsung Use ONLY)
RST	Button for resetting the OAS.
PWR LED	This LED indicates the power supply status. - Off: Power is not being supplied. - On: Power is being supplied properly.
RUN LED	This LED indicates MP20S status. - Off: Power is not being supplied. - On: Booting. - Blink: The RAM program is operating.
LAN Tx LED	This LED indicates the transmit status of the LAN port. - Off: Data is not being transmitted. - On or blink: Data is being transmitted.
LAN Rx LED	This LED indicates the receive status of the LAN port. - Off: Data is not being received. - On or blink: Data is being received.
SVC1 LED	This LED indicates if the MOBEX DSP service is being offered. - This LED blinks when program is being modified or configuration is being loaded.
SVC2 LED	This LED indicates if the LAN connection is alive. - This LED blinks when program is being modified or configuration is being loaded.
SVC3 LED	This LED indicates if the MPS channel service is being offered. - This LED blinks when program is being modified or configuration is being loaded.
SVC4 LED	This LED indicates if the MGI channel service is being offered. - This LED blinks when program is being modified or configuration is being loaded.

3.3.19 4WLI

The 4WLI (Wireless LAN Interface) provides connectivity for wireless points to the OfficeServ 7200 system. A maximum of 3 4WLI boards can be installed per system. This board can go in slots 1 through 5 of either cabinet.

SPECIFICATIONS

The specifications of the 4WLI board are as follows:

- Up to four APs per 4WLI board.
- Simultaneous calling through up to four channels per AP.
- The maximum number of mobile station subscribers is 120.

[Refer to Section 7.1.6 for Pinout and Wiring.](#)

FRONT VIEW OF 4WLI BOARD

The front view of the 4WLI board is shown in the picture below.

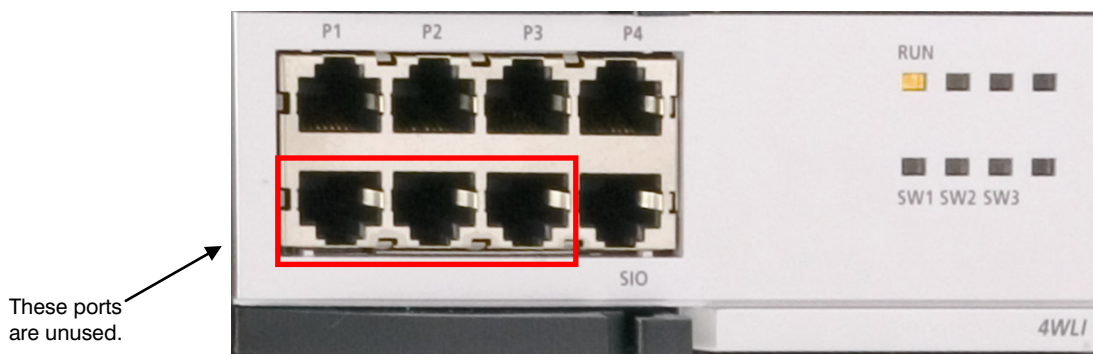

Figure 3.46 Front View of the 4WLI Board

Table 3.22 Ports and LEDs of the 4WLI

Ports & LEDs	Function Description
P1~P4	Port that connects with the WBS24.
SIO	Serial Port (for Samsung Use ONLY).
RUN LED	This LED turns on when the wireless LAN operates.
SW1~SW3 LED	This LED turns on when the software task operates.

3.3.20 4DSL

This board extends the Ethernet data connectivity to a remote location up to 1 km away over standard telephone wire pairs (P1~P4). The remote location must have Samsung VDSL modem (SVM-39A-LX) to terminate the line coming from the 4DSL board (P1~P4). This board can be installed in slots 1~5 of either cabinet. Add as many as required.

SPECIFICATIONS

- 4 x DSL ports
- Transmission distance: 1Km
- Up/down link:
 - 0~300m: Downstream 30Mbps, Upstream 10Mbps
 - 300m ~ 1Km: Downstream 20Mbps, Upstream 3Mbps

FRONT VIEW OF 4DSL BOARD

The front view of the 4DSL board is shown in the picture below.

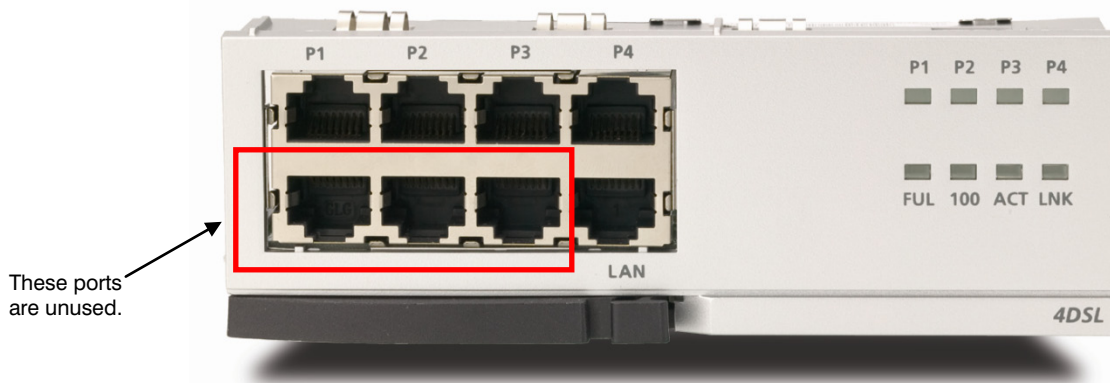

Figure 3.47 Front View of the 4DSL Board

The components on the front panel of the 4DSL have the functions below:

Table 3.23 Ports and LEDs of the 4DSL

Ports & LEDs	Function Description
P1~P4	Ports that connect the VDSL.
LAN	Ethernet port of 10 Base-T/100 Base-Tx for connecting with the higher-level Intranet.

Ports & LEDs	Function Description
P1~P4 LED	These LEDs indicate the status of the ports. - Off: The link is not connected. - On: The link is operating. - Blink: The data is being transmitted/sent.
FUL	Checking Full/Half duplex Operation(LED on at full)
100	Checking 10/100M speed(LED on at the speed, 100M)
ACT	LED Blinks on transmission/receipt of data.
LNK	Checking if the link is connected.

Refer to figure 3.48 below for the wiring in P1~P4.

P1-P4 Port (RJ-45)

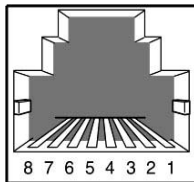

PinNo.	1	2	3	4	5	6	7	8
P1-4	-	-	-	TIP	RING	-	-	-
LAN	Tx+	Tx-	Rx+	-	-	Rx-	-	-

Figure 3.48 4DSL Card Ports (P1~P4) Wiring Pinout

3.3.21 SVMi-20E

The SVMi-20E card can be installed in the OfficeServ 7200 and OfficeServ 7400 Systems.

This section provides the additional steps required to set up the SVMi-20E for operation in the OfficeServ 7200. Included is other basic information regarding components making up the SVMi-20E. *Refer to the SVMi-20E Documentation for General Description, Installation, Programming and other Guides for all details including optional modules and their installation.*

SVMi-20E FRONT PANEL

The front view of the SVMi-20E board is shown in the picture below.



Figure 3.49 SVMi-20E LED Indications

The SIO Interface: This is a serial interface used to connect a modem or PC to provide local or remote PC based administration of the SVMi-20E.

The LAN Interface: An Ethernet port used for local or remote PC administration of the SVMi-20E. The main purpose for this connector is for system file transfer (Back-up and Restore) as well as for use with E-Mail Gateway functionality. The SVMi-20E is designed to back up and restore data to the customer provided LAN, or directly to a PC or Laptop connected to this LAN connector. The E-Mail Gateway functionality is used to send voice messages to E-Mail.

RST Button: The recessed button marked RST is the SVMi-20E reset button. Pressing this will immediately restart the SVMi-20E system and disconnect any calls in progress. Since pressing the RESET button during operation will disconnect all callers and immediately restart the SVMi-20E, it should only be used with caution. Pressing this button when the system is performing Disk I/O could result in data loss or file corruption. This button should not be pressed if the SVMi-20E is actively processing calls.

LED INDICATIONS

There are eight (8) LEDs on the SVMi-20E, the one marked HD will flash whenever the hard disk drive is being accessed, others will give indications of various board functionality.

- **VM1 Status LED:** This indicates that one or more of the embedded ports (port 1 thru 4) are off hook.
- **VM2 Status LED:** This indicates that one or more of the ports on the 1st installed VPM are off hook.

- **VM3 Status LED:** This indicates that one or more of the ports on the 2nd VPM are off hook.
- **HDD Access LED:** The HDD access LED will flash whenever the Hard Drive or CF is being accessed.
- **LAT Status LED:** This indicates that the LAN port is active.
- **LRT Status LED:** This indicates that the LAN port is receiving and/or transmitting data.
- **SDN Status LED:** This is the System Status LED showing the operating status of the card. A status of green indicates the SVMi-20E is down and it is safe to power off the switch. A status of red indicated the SVMi-20E is up and running and it is NOT safe to power down the switch without possible corruption to the SVM databases.
- **PGD Status LED:** Green indicates that good power is being provided to the SVMi-20E through the Back Plane

INSTALLING THE SVMi-20E

When installing a SVMi-20E card, it is important to remember that it is a single board computer (SBC), much the same as any desktop PC and it is therefore very important not to exceed these environmental limits. Note: Before installing this card it should be correctly configured with the appropriate drive, number of Voice Processing Modules (VPMs), and all other optional add on modules (Modem and/or 64MB DRAM).

When configuring the SVMi-20E for more than 16 ports it should be installed in slots 3, 4 or 5 of the main 7200 cabinet as these are 32 channel slots. When 16 or less ports are used the SVMi-20E can be installed in any universal slot in the system.

IMPORTANT NOTE: If one 8 port VPM module and one 4 port VPM module are used, the 8 Port VPM must be used in connector S2 which is the third position. If reversed, no VPM ports will come into service. (See table below).

Table 3.24 VPM Configuration

Configuration	Included on SBC	VPM in SL2	VPM in SL3	Total Ports
1	4	None	None	4 Voice
2	4	VPM-E	None	8 Voice
3	4	VPMF-E	None	8 Voice Supporting 1 Fax
4	4	VPM-E	VPM-E	12 Voice
5	4	VPM-E	VPMF-E	12 Voice Supporting 1 Fax
6	4	8VPMF-E	None	12 Voice Supporting 1 Fax
7	4	VPMF-E	VPMF-E	12 Voice Supporting 2 Fax
8	4	8VPMF-E	VPM-E	16 Voice Supporting 1 Fax
9	4	8VPMF-E	VPMF-E	16 Voice Supporting 2 Fax
10	4	8VPMF-E	8VPMF-E	20 Voice Supporting 2 Fax

Note: The Fax DSP does not increase the available ports. It adds the fax functionality to any voice port in the SVMi-20E.

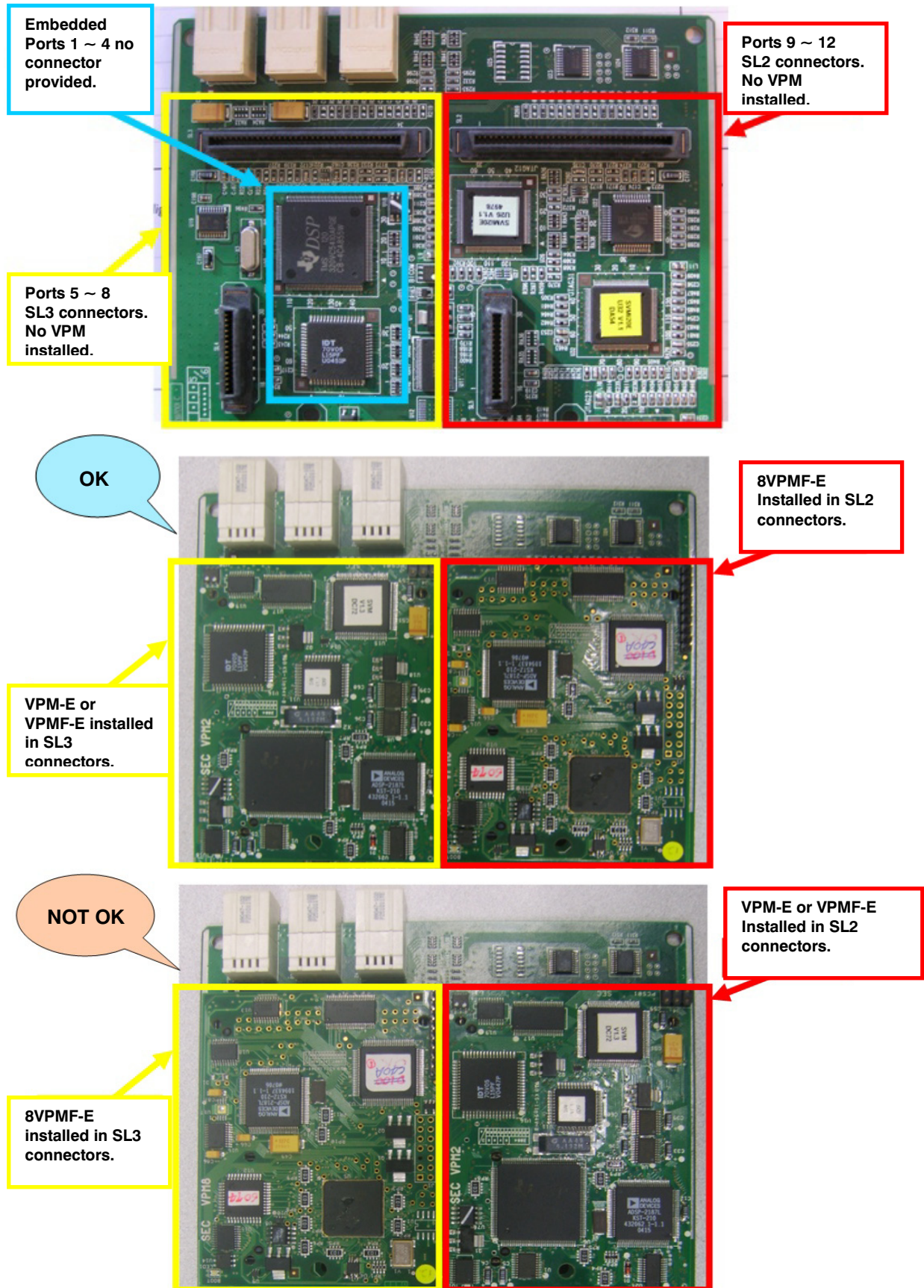

Figure 3.50 VPM-E, VPMF-E and 8VPMF-E Combinations

GENERAL

- **POWER REQUIREMENTS:** Because the SVMi-20E does NOT draw from the -48DC supply, it has a zero (0) SEPU rating in all possible configurations
- **OfficeServ 7200 HARDWARE COMPATIBILITY:** All versions of the OfficeServ 7200 are compatible with the SVMi-20E. With the introduction of the 8VPMF-E module the SVMi-20E can now be configured for up to 20 ports. When configured for 20 ports it must be installed in slots 3, 4, or 5 of the main cabinet.
- **OfficeServ 7200 SOFTWARE COMPATIBILITY:** SVMi software version 5.3.3.3 or higher and OfficeServ 7200 MP software version 4.30 or higher are required to support more than 12 ports on the SVMi-20E card.

INSPECTION

Unpack and inspect the unit for any obvious damage. This card should be labeled SVMi-20E. If it is not, you have the wrong card.

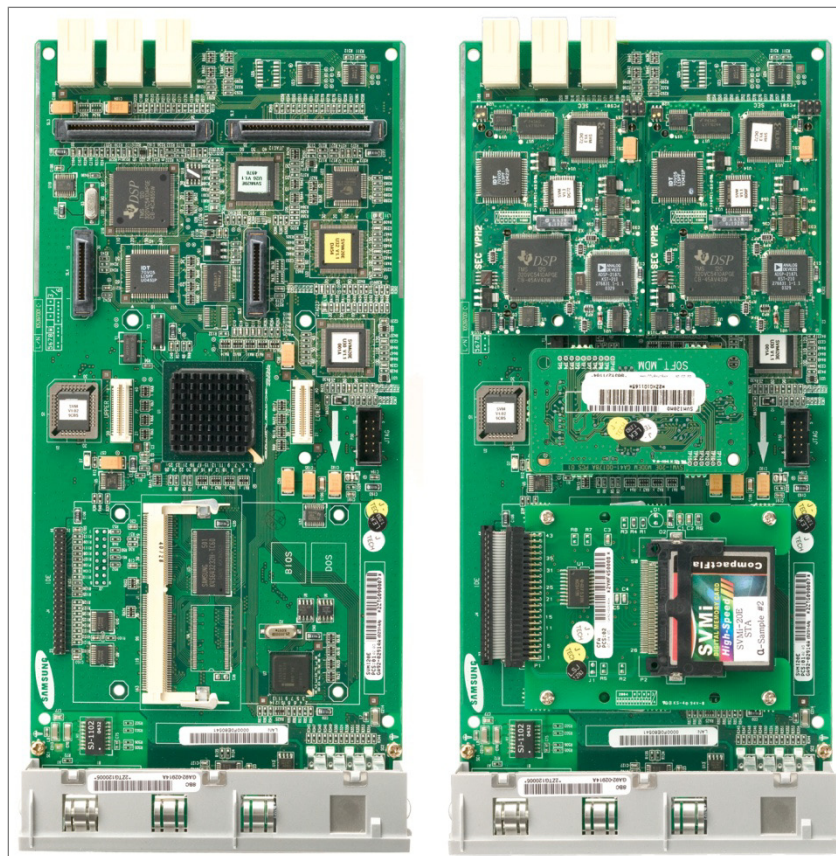

Figure 3.51 SVMi-20E/HD with no optional boards installed (LEFT)
and SVMi-20E/CF with all components installed (RIGHT)

INSERTING THE CARD

NOTE: Before powering off the KSU, it is recommended that you use MMC 740 and set MBX Download to 'No'.

The SVMi-20E card can be installed in any slot (1~5) of any cabinet. When configured for 20 ports, slots (3~5) of the main cabinet must be used. Check that the OfficeServ 7200 system's power switch is in the OFF position. Next, position the SVMi-20E card in the grooves of the card guide and gently slide the card in until it makes contact with the connector. Press gently but firmly on the left and right of the front edge of the card until the card seats in its connector. Press firmly on the Black Front Panel Lever until it snaps securely in place. The cabinet can now be turned on.

If the SVMi-20E card is being installed in an existing system, you will have to use MMC 806 to pre-install the card and MMC 724 to assign extension numbers to each SVMi-20E port. Use any available numbers.

After the SVMi-20E card is installed, either in a new or existing system, you will have to use MMC 601 and assign all the SVMi port numbers to the last available station group (Group Number 5039 by default).

POWER UP PROCEDURE FOR SVMi-20E

Follow the steps below to ensure that the SVMi-20E is properly setup.

POWER UP

1. Complete insertion of the SVMi-20E and all other required interface cards and turn the system power switch ON.
2. There are 8 LEDs on the front of SVMi-20E. We will watch three during power up: the PGD, HDD, and the SDN LEDs.

POWER UP LED CONFIRMATION

- The PGD LED will show steady green when the SVMi-20E is receiving power from the OfficeServ 7000 Series Back Plane connectors.
- The HDD LED will show hard drive access and will flicker whenever the HDD (hard drive) is being accessed.
- The SDN LED will start off Green as the SVMi-20E is booting up (it will also turn Green when the SVMi-20E is shut down properly). It will turn Orange after the Voice Drivers are loaded into memory and then turn RED when the application software is fully loaded. RED is warning letting you know the application is running and it is NOT safe to power down the OfficeServ 7200 system.

SETTING UP THE SVMi-20E WITH THE OFFICESERV 7200 PHONE SYSTEM

This section provides the additional steps required to set up the SVMi-20E card for operation in the OfficeServ 7200 system. Included here is information regarding the software set up for the phone system.

After inserting the SVMi-20E card and turning the power on there are some important system options that should be set in order for the SVMi-20E to function correctly. These steps are performed in the phone system program. It is necessary to perform these at this time so that the SVMi-20E will initialize properly and synchronize its mailbox database with that of the key system.

SYSTEM PROGRAMMING

Review and perform the following programming steps 1 through 7. It is necessary to perform these at this time so that the SVMi-20E will read these MMCs and initialize accordingly.

NOTE: Before moving forward if you want to change any of the SVMi-20E default Extension and Mailbox settings it is best to edit your Extension and Mailbox Templates now before initializing the SVMi-20E.

1. MMC 601: All SVMi-20E ports installed must be assigned to the last station group (by default the last group number is 5039). This should be identified as Bi-VMS group type by OSM or Installation Tool.
2. MMC 601: Select either SEQUENTIAL or DISTRIBUTED ring mode (Sequential is recommended).
3. MMC 207: Confirm that all SVMi-20E ports are set for VMAA use. This will be done automatically. You are just confirming at this point.
4. MMC 406: If you are using the SVMi-20E for Auto Attendant use MMC 406 to set the desired trunk(s) to ring station group 5039.
5. MMC 102: If you are using the SVMi-20E for Voice Mail make sure that all desired stations are forwarded to station group 5039 for the appropriate call forward conditions: No-Answer, Busy, and/or ALL.
6. MMC 740: Set "MBX Download" is to YES.
7. MMC 741: Select "NO" for each station that you DO NOT want to create a mailbox for.

INITIALIZING THE SVMi-20E

Perform a proper SVMi-20E system shut down. (Steps for performing a proper shut down are described in the section Correct System Shutdown.)

Once the SVMi-20E is down and at a C:> DOS prompt, press the RESET button this will reboot the SVMi-20E. During the reboot process the SVMi-20E will communicate through a series of IPC messages to the MCP/MP20 to read the MMC data and initialize the SVMi-20E accordingly.

NOTE: After the SVMi-20E restarts you should change the value of MMC 740 so that it indicates "MBX Download = No." This will prevent the system from creating new mail boxes and overwriting any future changes you make to the SVMi-20E database in regards to EXT and MBX Blocks.

TESTING THE HARDWARE

1. Call each SVMi-20E port individually and confirm that SVMi-20E answers.
2. Call the BI-VMS station group (generally 5039) and confirm that SVMi-20E answers.

If steps 1 and 2 above proved to be successful you have completed the installation and setup of the SVMi-20E hardware.

You are now ready to begin programming the SVMi-20E Voice Mail/Auto Attendant system parameters. See the SAMSUNG SVMi-20E Programming Manual.

NOTE: See MMC references in the SVMi-20E Programming Overview documentation for other MMCs that interact with the SVMi-20E.

CORRECT SYSTEM SHUTDOWN

Whenever possible one of the following procedures should be followed when shutting down the SVMi-20E system and/or prior to shutting down the telephone equipment.

PROCEDURE ONE

1. From any phone on the system log into KMMC Programming.
2. Using MMC 746 change the status of the SVMi-20E from "processing" to "Halt".
3. The SDN LED on the front of the SVMi-20E will change from RED to Green. Green means it is safe to power down the switch.[†]

PROCEDURE TWO

From the Main Status Screen (showing activity and port status):

1. Press 'Escape' and enter System Administration password (Default = 0000).
2. Select 'Operating Utilities'.
3. Select 'Exit the SVMi-20E'.
4. Enter System Administrator's password (Default = 0000).
5. The SDN LED on the front of the SVMi-20E will change from RED to Green. Green means it is safe to power down the switch.[†]

PROCEDURE THREE

1. From any phone on the system call one of the SVMi-20E ports or call the Bi-VMS station group (generally 5039).
2. If the SVMi-20E answers with "please enter your password" press [*] to escape to the main menu.
3. From the main menu press [#][0000].
4. You will be again prompted to enter a password, enter the System Administrator's password (Default = 0000).
5. You will be prompted with "System Administration Menu" and a list of functions that you can perform. It will not be spoken, but you can enter a hidden option [4] to shut down the system.
6. Again you will be asked to enter a password, enter the System Administrator's password (Default = 0000).
7. The system will now shutdown to a C:> DOS Prompt. The SDN LED will turn from RED to GREEN. Green means it is safe to power down the switch.[†]

[†] Also if you are logged in via an SIO Terminal, when the SVMi-20E terminal emulation screen shows a DOS command line this also means the SVMi-20E is no longer processing and it is safe to power off the system and unplug the SVMi-20E card.

3.3.22 CONFERENCE CARD (CNF24)

The CNF24 provides 24 ports of voice conference services per card and supports transceiver function of packet data converted from voice data through the data network. The users can be internal and external participants using SIP trunks, PRI trunks, and SPNet trunks.

A CNF24 card provides conference sizes from 2 to 24 users per card. The maximum recording capacity per card is 50 hours, and concurrent recording channel is restricted to 6 channels. The main function of this card is the Meet-Me-Services function where users will dial into a conference bridge number. Additional services support Ad hoc services.

CNF24 MAJOR FUNCTIONS

- Supports Meet-Me conferences in which participants make a phone call to the phone system to attend the conference.
- Supports Ad hoc conferences in which the host calls each member to invite him/her to participate in the conference.
- Permits a participant to enter the conference after notifying members in the conference.
- Provides the conference host additional functions during the conference by using a Conference webpage.
- Simple and easy conference set up.

CNF24 FRONT PANEL

The front view of the CNF24 card is shown in the picture below.



Figure 3.52 Front View of CNF24 Card

Table 3.25 CNF24 Front Panel Components

Ports & LEDs	Function Description
LAN	Port that connects the Ethernet. Connector: RJ45 Cable: CAT 5 cable, UTP.
SIO	UART Port (For Testing Only). Serial Port.
RST	Button for resetting the CNF24.
RUN LED	This LED indicates CNF24 status. - Off: Power is not being supplied. - On: Booting. - Blink: The RAM program is operating.
SVC LED	This LED indicates if the CNF24 service is being offered. This LED turns on when the CNF24 software task can be serviced. - Blink Red: CNF24 service is not available. - Blink Green: CNF24 service is available.
LAN LED	This LED indicates the status of the Ethernet link. - Red: Linked as 10 BASE-T Ethernet mode. - Blink Red: Transmitting/receiving data as 10 BASE-T. - Green: Linked as 100 BASE-TX Ethernet mode. - Blink Green: Transmitting/receiving data as 100 BASE-T. - Orange: Linked as 1000 BASE-TX Ethernet mode. - Blink Orange: Transmitting/receiving data as 1000 BASE-TX. -Off: Link off.
MC LED	- Blink Green: Auxiliary memory (NAND) is accessed. - Off: No access.

Ports & LEDs	Function Description
CONF LED	This LED indicates the number of conference channels being used. - Green: 1~8 channels - Orange: 9 ~16 channels -Red: 17~24 channels -Off: No Conference
REC LED	This LED indicates the number of recording channels being used. - Green: 1~2 channels - Orange: 3 ~4 channels -Red: 5~6 channels -Off: No Recording
MEM LED	This LED indicates the capacity status of the recording storage. - Green: 0~49% of recording storage is used - Orange: 50~69% of recording storage is used -Red: 70~79% of recording storage is used -Blink Red: 80% of recording storage is used
BACKUP LED	This LED indicates the status of the backup operation. - Green Blink: Makes backup of the recorded data to the web page - Off: No operation -Red: 70~79% of recording storage is used -Blink Red: 80% of recording storage is used

SYSTEM CAPACITY

The CNF24 has 24 conference channels and a maximum of 2 cards can be installed on the OfficeServ 7200 system.

The number of conference groups will increase when additional CNF24 cards are installed. When recording and/or paging features are used the number of conference members allowed to attend the conference is decreased since the recording and paging features occupy one conference channel each. See table below for details.

Table 3.26 Maximum Conference Capacity

System	Max # of CNF24	Max # of Conference Members
OfficeServ 7200 (MP20)	2	24 members, 2 groups (Without recording or paging)

PORT ASSOCIATION

Table 3.27 CNF24 Port Association

Classified Port of CNF24	Default Port	The associated DB of DM for remote ports after setting NAT rule
RTP port	Start port :30000 (Available to change) (Even # up to 24 port : 30000-30046)	Start port : DM 2.2.16 Public RTP port 1 (Even # up to 24 port)
FTP port	21 (Fixed)	DM 2.2.16 FTP port
Upgrade port	60024 (Fixed)	DM 2.2.16 Upgrade port

SLOT INFORMATION

If the CNF24 card is installed on a slot that supports more than 24 channels, all 24 conference channels are used. If installed on a 16 channel slot, only 16 conference channels are supported.



Figure 3.53 CNF24 Slot Information

CNF24 SETUP

To setup the CNF24 card follow the steps below:

1. Install the CNF24 card on the system.
2. Connect network cable with CNF24. The CNF24 card can be installed normally without being connected with a networking cable but conference services will not be operational.
3. The RUN LED will blink when the CNF24 card is ready to provide conference service. User can check the CNF24 software version and CPLD/PCB version in Device Manager 2.2.0.
4. Enter the CNF24 IP address in Device Manager 2.2.16 or in MMC 871. The CNF24 card will restart automatically to apply the new network settings.

2.2.16.CNF24 Card	
Cabinet/Slot	C1-S4
IP Version	IPv4
IP Address	10.254.168.132
Gateway	10.254.168.1
Subnet Mask	255.255.255.0
IP Type	Private Only
Local RTP Port(start)	30000
Public IP Address 1	0.0.0.0
Public RTP Port 1	30000
Public IP Address 2	0.0.0.0
Public RTP Port 2	30000
Public IP Address 3	0.0.0.0
Public RTP Port 3	30000
FTP port	21

Figure 3.54 CNF24 Parameter Settings

5. Enter the Service License key in DM 2.1.4 or MMC 860 for the CNF24 channels to become available.

License Key		NLWUJHCL-KHPW300-OGYSLSM8-MJ6J70X5-86UAZ7RG-NN6YAYMY
License Status		OK
H.323	Allowed	24
Soft Phone	Max Count	64
	Connected	0
MOBEX Executive	Max Count	64
	Connected	0
IP Phone	Max Count	64
	Connected	0
WiFi Phone	Max Count	64
	Connected	0
SPNET Feature	Allowed	Enable
Call Manager	Allowed	64
Conference	Max Count	24

Figure 3.55 Input Service License Key

CNF24 LICENSE

A license per channel is required to use the conference service. The maximum number of channels allowed per OfficeServ 7200 system is 48 (2 CNF24 cards x 24 channels).

SW3 - SVC

LICENSE KEY	
NQUMWELH-PLJWZMLP-LUHCLIU9-H1A8FRMM-74DVPS3Y-7ZTCHYEQ	
BASIC INFORMATION	
Country	
Purpose	
Description	
User Name	
Tel	
MAC Address	
MAC Address Type	
Switch Type	
License Type	
CAPACITY	
H.323 Trunk Count	10
SoftPhone Count	10
IP Phone Count	10
Mobex Executive Count	10
WIFI Phone Count	10
Call Manager(OS COMM)	10
Conf Bridge Port Count	24
SPNet	Nonuse
Duplexing	Nonuse

Figure 3.56 CNF24 License

UPDATING CNF24 SETUP INFORMATION

Each CNF24 card has a unique MAC address, and the OfficeServ system uses the MAC address to manage the card information. If the card location is changed, the user is required to update the setup information as follows:

1. When the CNF24 card is installed in slot A no update is required.
2. When the CNF24 card is originally installed in slot A and then moved to slot B, the CNF24 information is automatically updated but user is required to delete slot A information in Device Manager 6.3.1.
3. When installed CNF24 card is pulled out and replaced with a new CNF24 card installed in the same slot, MAC address of the new card is updated automatically.
4. When existing CNF24 card installed in slot A is pulled out and it is replaced by a new CNF24 card installed in slot B, user is required to clear Slot A setup information in Device Manager 6.3.1 and assign new CNF24 IP address in Device Manager 2.2.16.

CNF24 CARD STATUS

The OfficeServ system provides conference services when the CNF24 card status is active.

In the following cases the card status will change to idle:

1. LAN connection between system and CNF24 card
System checks the card status every 5 seconds and if the network cable of the CNF24 card is disconnected, system will restrict all conference services until LAN connection is recovered.
2. Card Parameter Setting
When IP address is not assigned to CNF24 card, the system can't check card status. Every time a new CNF24 card is installed user must assign an IP address.
3. Service License Key
License key is required to use conference service. Without a license key, a "NO CONFERENCE CHANNELS ARE AVAILABLE" message displays on the phone. Check service license key in case of system initialization or change country selection.

UPGRADING CNF24 CARD SOFTWARE

To upgrade CNF24 software follow the steps below:

1. Select the **[Util]** menu option.
2. Select **Package Update**. Conference Card Package Update window displays.

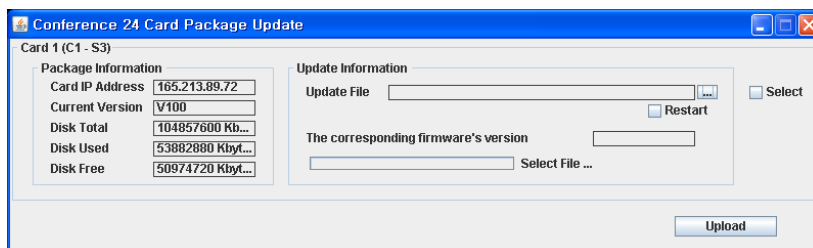

Figure 3.57 CNF24 Package Update

3. Click on [...] to select file to update. When file is selected the "Corresponding Firmware Version" will display.
4. Click on **Select** checkbox.
5. Click on the **Upload** button to start the upload process. The progress bar displays the current state.

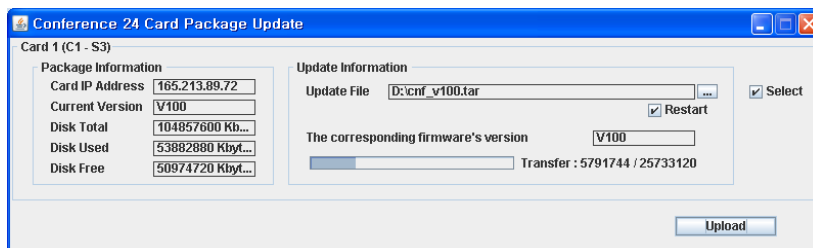

Figure 3.58 CNF24 Progress Bar

3.4 CONNECTING POWER FAIL TRANSFER

The OfficeServ 7200 offers a Power Fail Transfer feature for analog single line telephones that are connected to port 1 on the 8SLI/8SLI2, 16SLI2, or 16MWSLI cards.

In case the OfficeServ 7200 loses power from its AC source, and no battery backup is available, this feature is automatically activated. The SLT connected to Port 1 of the SLI will get C.O. dial tone (direct C.O. line access) activated by an internal relay. For this feature to work, the SLI ports must be wired as shown in Figure 3.52 Pin 4 (TIP) and Pin 5 (Ring) from a port on the 8TRK/8TRK2 card must be connected to Pin 1 (TIP) and Pin 2 (Ring) on port 1 of an SLI card.

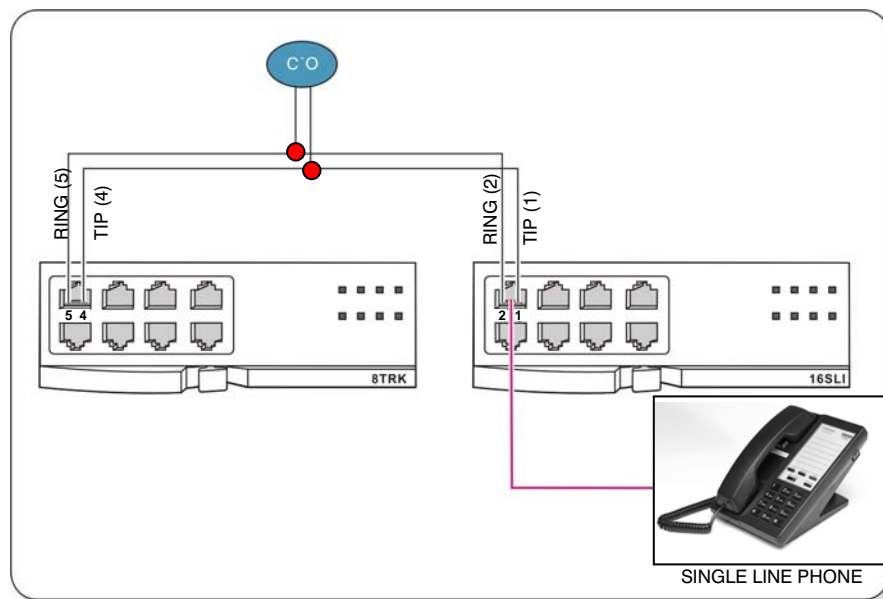

Figure 3.59 Power Fail Transfer Connection to 16MWSLI/16SLI2/8SLI/8SLI2

PART 4. CONNECTING EXTERNAL BATTERIES

This section describes how to connect external batteries to the OfficeServ 7200 system.

4.1 CONNECTING EXTERNAL BATTERIES

CAUTIONS FOR CONNECTING EXTERNAL BATTERIES

External batteries are required to maintain stable operation of the OfficeServ 7200 system in case a power failure occurs. Rated capacity of an external battery is DC 48V and 45AH per cabinet. Batteries should be connected to each cabinet to guarantee safety. A fuse (125VAC, 5Amp) should be positioned between the output terminal of the battery and the cabinet.



Cautions for connecting external batteries

Do not connect external AC power to the system before completing the connection between batteries and the system. If so, it may cause electric shock. Check the specified polarity (+ or -) to connect external batteries.



To reduce risk of fire and injury to persons, use only a sealed nickel cadmium or lead-acid battery supply capable of handling a charge current of 0.45A, a charge voltage of -56VDC and a discharge rate of 45Ah.

The power supply provides -56VDC at 0.4 amperes charging current (i.e. when AC power is present) which allows for float charging from OfficeServ 7200 to emergency backup batteries. The OfficeServ 7200 can also run without AC power on a -48VDC battery system or rectifier. There should be no more than a 0.5VDC drop in voltage from the OfficeServ 7200 and the batteries. Ensure polarity prior to connecting the external -48VDC power source to the system.

The OfficeServ 7200 power supplies contain a monitoring circuit to switch the system to customer provided 48VDC batteries when AC power is interrupted. Calls in progress are not disconnected. The power supply circuitry monitors and recharges batteries as needed.

Connect four 12V batteries or eight 6V batteries in series. Any NICAD or lead acid (car or motorcycle type) battery can be used if its rating is not less than 6AH (amp hours) but no more than 40AH per power supply. The batteries must be located within three feet of the KSU. Use the factory-supplied wire harness with 36" white and black leads to connect batteries. ([see Figure 4.1](#)).

Observe the following precautions when installing batteries:

- Make sure the batteries you install conform to local building, fire and safety codes. Some battery types emit hydrogen gas during the charging state and may require venting to fresh air.
- Do not place batteries directly on a concrete floor. This causes them to discharge very quickly.
- Follow the battery manufacturer's recommended installation and maintenance procedures.

PROCEDURE FOR CONNECTING EXTERNAL BATTERY

The procedure for using a battery cable to connect an external battery to the OfficeServ 7200 system is as follows:

- 1) Prepare the battery cable that was provided with the OfficeServ 7200 system. An end of this battery cable consists of a white wire and a black wire.
- 2) Connect the white wire of the battery cable to the (+) terminal, and the black wire to the (-) terminal of the battery. Then, connect the other end of the battery cable to the external battery socket on the rear panel of the OfficeServ 7200 cabinet. When using two or more OfficeServ cabinets. Connect a separate battery to each cabinet.

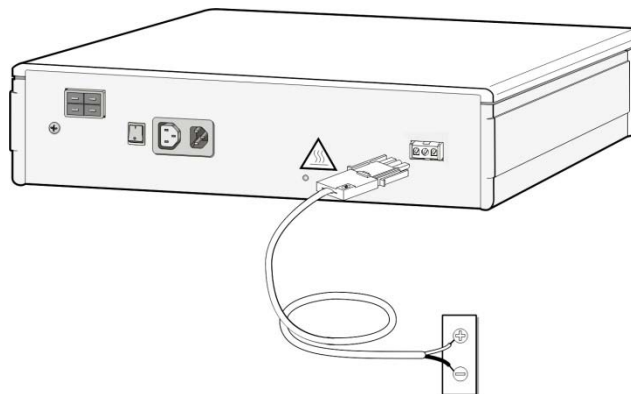

Figure 4.1 Connecting an External Battery (1)

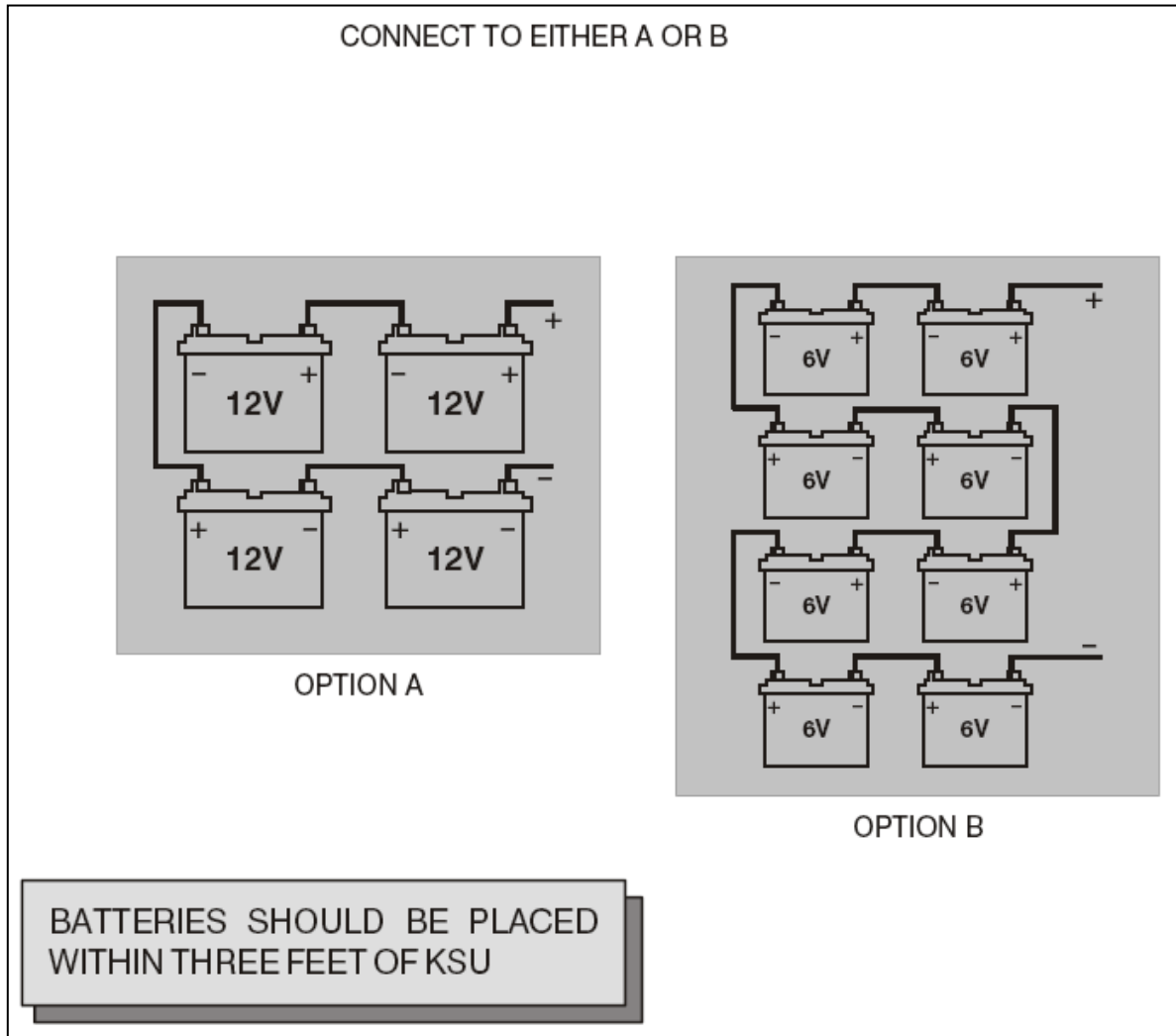

Figure 4.2 Connecting an External Battery (2)

PART 5. CONNECTING POWER

This section describes how to connect power to the OfficeServ 7200 system.

5.1 BEFORE CONNECTING POWER

When input power is normally supplied, the AC power is supplied to the Power Supply Unit (PSU), which charges the external battery. If the input power is interrupted, the system can be operated using the charged power of the external battery.

- Verify that the AC voltage at the dedicated electrical outlet is in the range of 88-132 VAC (USA ONLY).
- A single AC outlet should be used solely for the system's AC power. Sharing the AC power with other devices can cause noise or a voltage drop, resulting in a system malfunction or fire.
- Use a stable power source that can always supply AC power since instantaneous power failures can cause malfunctions or battery failures.
- [System should be grounded as described in Part 1.2 and Part 2.5.](#)

5.2 PROCEDURE FOR CONNECTING POWER

SINGLE CABINET CONFIGURATION

Use the power cable provided with the OfficeServ 7200 system to connect the input power terminal on the rear panel of the cabinet to a grounded outlet.

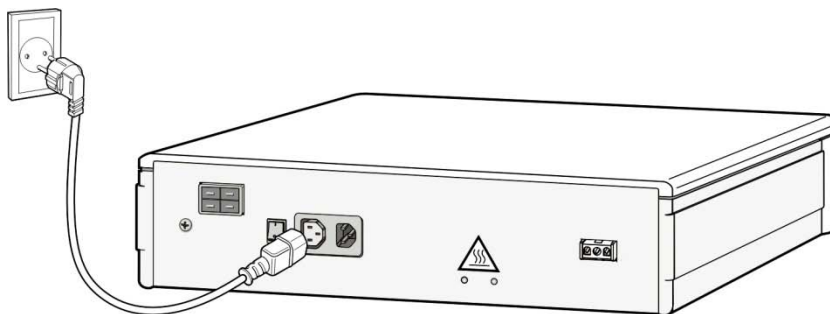

Figure 5.1 Connecting Power (for Single Cabinet)

MAIN AND EXPANSION CABINET CONFIGURATION

The connection procedure depends on the environment of the installation area as shown below. Select a procedure according to your environment.

- Connect each input power cable of the cabinets to a grounded outlet.



Figure 5.2 Connecting Power (using Power Cable)

- Or connect the input power terminal of the main cabinet to the grounded outlet, and use a power extension cable (included in LCP carton) to connect the power connectors of the main and expansion cabinet.

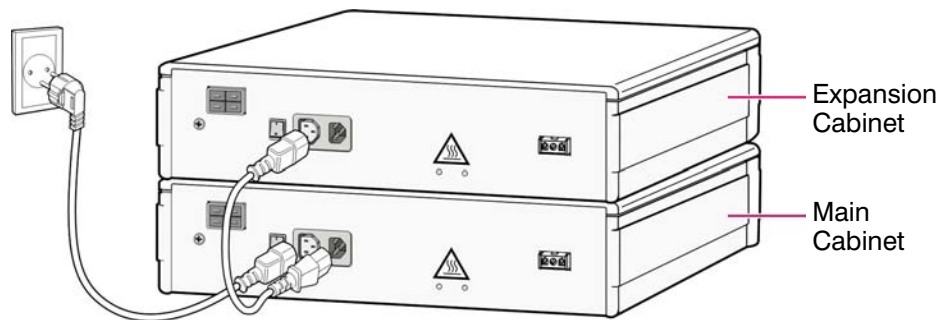

Figure 5.3 Connecting Power (using Power Extension Cable)

5.3 CONNECTING THE OFFICESERV 7150 EXTERNAL PoE PSU SUPPLEMENTAL POWER SUPPLY

The OfficeServ 7150 PoE PSU provides additional power to your OfficeServ 7200 cabinets when the internal OfficeServ 7200 PSU limits have been exceeded. It is composed of a cabinet which can accommodate up to two POE-M Power supply modules. Each module provides -54V, 7.5A. Depending on your power requirements, you can add either one or two modules. A two-module system (7150 with 2 PoE-M PSU module) provides -54V, 15A.

The PLIM/PLIM2 module uses the -48V rail from the OfficeServ 7200 power supply to provide power to the connected devices over ethernet. The OfficeServ 7200 power supply provides up to 2200mA of output current.

PER EACH OS 7200 CABINET (not per system), the SUM of all current drawn from 1) devices powered by PLIM/PLIM2 cards, 2) digital key sets connected to DLI ports and 3) analog devices connected to SLI ports and 4) COMBO WBS24 AP's connected to 4WLI cards cannot exceed 2200mA. The chart below provides current ratings for various devices connected to the system:

Table 5.1 Consumption per Device

Card Name	Connected Device Type	Current Consumption per Each Device (mA)
DLI	Digital Keyset	25
MWSLI	Analog Phone	25
	Analog Phone with Message Waiting Lamp	30
PLIM/PLIM2 (48 V)	ITP-5121D or ITP-5107S	100
	ITP-5112L	130
	SMT-R2000 Dual AP	200
	SMT-i3105	83
	SMT-i5210	127
	SMT-i5220, SMT-i5230	107
	SMT-i5243	156
	SMT-i5264	100
	A52GE Gigabit	56
	Other IEEE 802.3af compliant device.	See manufacture current draw specifications

IF ADDING PLIM/PLIM2 CONNECTED DEVICES CAUSE CURRENT DRAWN TO EXCEED 2200mA PER CABINET (not per system), THEN YOU MUST CONNECT THE OS7150 EXTERNAL PoE POWER SUPPLY MODULE to the cabinet. This unit will provide additional power only to devices connected to PLIM/PLIM2s when the OS7200 power supply limits have been exceeded.

It is important to note that the OS 7150 only provides additional power to the PLIM/PLIM2. The OS 7150 is used when the PLIM/PLIM2 connected devices cause the total current draw per cabinet to exceed 2200 mA. It does **not** provide power to DLI, MWSLI and 4WLI ports.

PRODUCT SAFETY



Grounding Requirements

- [Follow all grounding conditions listed in Section 1.2.](#)
- The grounding wire of OfficeServ 7150 PoE PSU should not be connected to the conduit of the power cables in the building.
- Power and grounding cables should meet the national standard. Installation of them shall be based on the national standard.
- Grounding should be made to an outside port to protect human body as well as OfficeServ 7150 PoE PSU from lightning, static electricity and instantaneous over voltage.
- The system should be connected to a properly grounded electric outlet.
- The GND ground on the rear panel of OfficeServ 7150 PoE PSU should be properly connected.



Use caution when connecting External Battery DC Output Connection

Do not drive another device with the DC output of the external battery of the OfficeServ 7150.



When inserting and removing the PSU modules from the cabinet, all power should be turned OFF.

Connecting Grounding Wire

Unplug AC power cable before grounding wire is connected.

Use of Double-Pole Neutral Fusing

It is dangerous to carry out repair work with single fuse removed from the double pole neutral wire.



Do Not Wear Metallic Accessories

To prevent electrical shock, do not wear metallic accessories while handling the product.



FOLLOW ALL SAFETY AND GROUNDING GUIDELINES MENTIONED IN [SECTIONS 1.1.1 and 1.2.](#)

OFFICESERV 7150 FRONT VIEW

Front view of the OfficeServ 7150 cabinet is as shown in the following illustration. The cabinet consists of two slots and one distributor. A PoE-M PSU module is inserted to each slot.

Each PoE-M module contains an AC power switch and a module LED. The distributor consists of an external battery power switch and a modular alarm jack (*alarm jack is not used. Reserved for future use*).

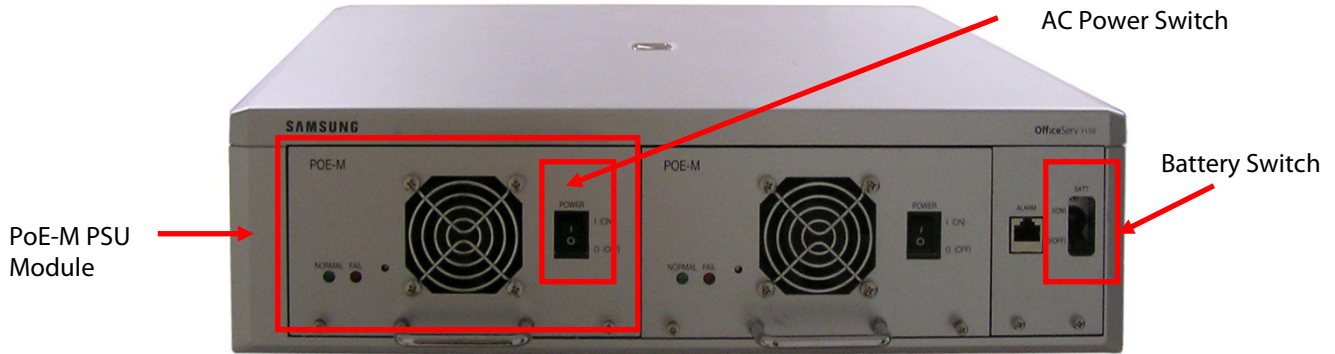

Figure 5.4 Front View of OS 7150 Cabinet

OFFICESERV 7150 REAR VIEW

Rear view of the cabinet contains an external battery connection port, a power connector, a DC output connection port and a grounding port.

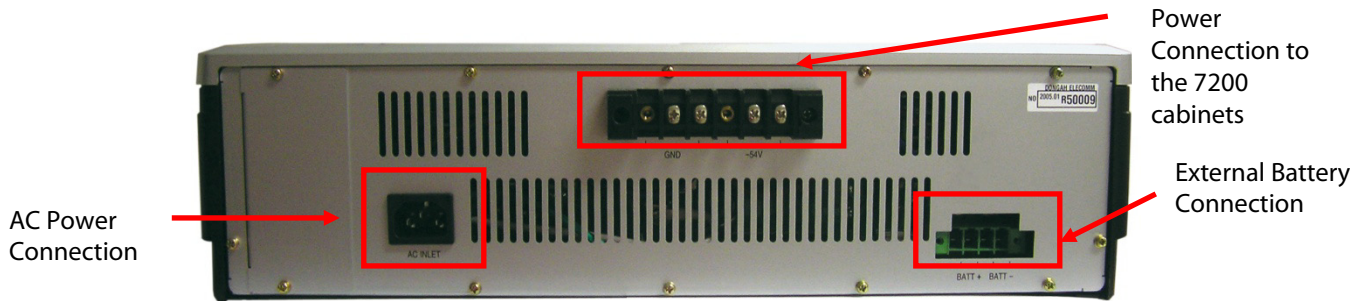

Figure 5.5 Rear View of OS 7150 Cabinet



PARTS

The Offiserv 7150 cabinet (KP-OSDBRES/XAR) comes with the following parts:

- PoE Cable 1 each
- Battery cable 1 each
- AC Power cable(110V Type) 1 each
- Alarm cable 1each (not used for OfficeServ 7200 systems)
- 19" Rack mount kit 1set

The POE-M PSU modules are sold separately. Extra PoE cables can be purchased if needed.

OFFICESERV 7150 INSTALLATION

 WARNING	<p>Safety Conditions</p> <ul style="list-style-type: none">• Follow all site requirements listed in section 1.1.1.• Before installing OfficeServ 7150 PoE, check electric cable connection, grounding, voltage and frequency status.• The building where OfficeServ 7150 PoE is installed should be protected properly against lightning and electric leakage using arresters or grounding.• OfficeServ 7150 PoE must be mounted on a leveled surface or rack..• Keep the OS7150 away from static electricity.• Input power of OfficeServ 7150 PoE should be AC 88~264V. Do not use the system with motors or compressors.
 CAUTION	<p>Temperature/Humidity Conditions</p> <p>Following environmental conditions should be maintained:</p> <ul style="list-style-type: none">• Operating Temperature : 32°~113°F• Storage Temperature : 14° ~ 122°F• Humidity : 10~90% <p>The system should be installed at a cool, dust-free place without direct sun light and proper air ventilation.</p>

GROUNDING CONDITIONS



Observe the following requirements when OfficeServ 7150 PoE is grounded.

- The grounding wire of OfficeServ 7150 PoE shall be connected to the ground through a qualified grounding media.
- Conductivity between the leaked metallic surface of OfficeServ 7150 PoE and the grounding wire of the power plug shall be normal.
- When all the grounding wires from all external auxiliary devices are connected to the system ground point, the connection shall be made through a single contact.

POWER CONDITIONS

OfficeServ 7150 PoE Power Supplies operate with AC input voltage or battery power. The power supply system feeds DC 54V to 7200 system.

Power supply conditions:

- AC 88-264V~;15A;50/60Hz or DC48V \equiv 30A
- AC 88-264V~;12A;50/60Hz or DC48V \equiv 30A



When connecting a power source to OfficeServ 7150 PoE, observe the following requirements:

The system should be connected to an AC outlet exclusively. If the AC source is shared with other devices, noise or voltage drop may cause system malfunction or fire.

Instantaneous power failure may cause system malfunction or battery failure. Therefore, stable AC power should be supplied.

INSTALLATION PROCEDURE

This section describes how to install OfficeServ 7150 PoE on the floor or inside a rack.



Select an Installation Method

OfficeServ 7150 may be installed either on the floor or inside a 19" inch rack.

- 1) Ground the system to the grounding lug at the rear side of 7150. ([See Page 5.12](#))
- 2) Remove the blanking plate from the slot where the POE-M PSU module is to be inserted.



Do not remove a blanking plate from unused slots.

- 3) Insert the PoE-M module into the slot.
- 4) Connect an external battery with proper capacity if required.
- 5) Connect AC input voltage.

INSTALLATION IN A RACK

- Install in a standard 19" data rack.
- If an enclosed rack is used, check if proper ventilation system has been installed in the rack.
- If an open rack is used, do not to block the front of the OfficeServ 7150 fan.

Tools Required

- One medium size Phillips screw driver
- One cross bar bracket and three screws
- Two rack mount brackets and six screws
- Two fixing screws

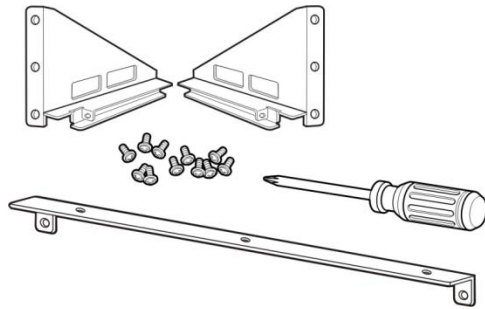

Figure 5.6 Tools Needed for Installation in a Rack

- 1) Attach the cross bar bracket to the bottom of OfficeServ 7150 PoE, and tighten with three screws.

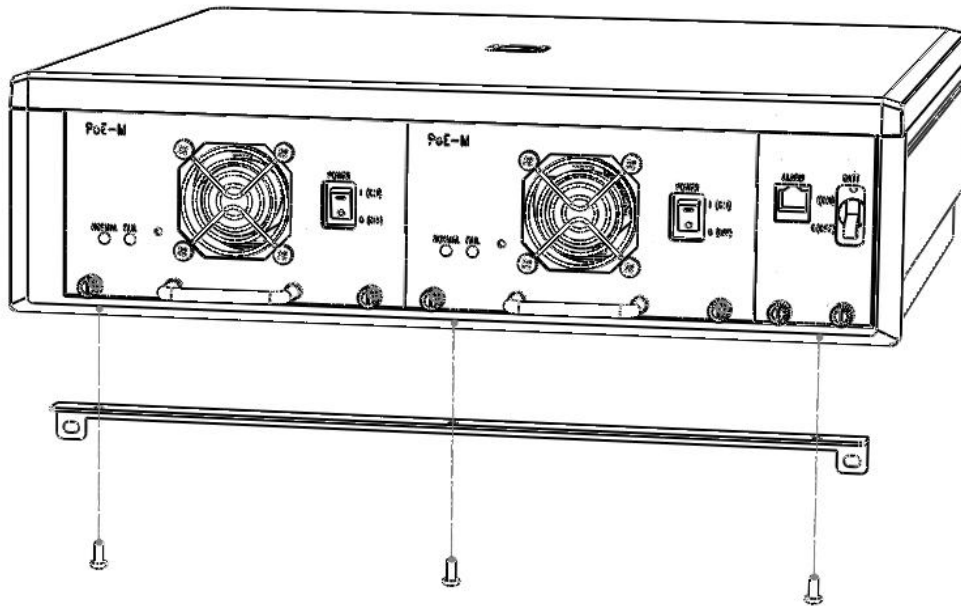

Figure 5.7 OS 7150 Installation in a Rack (1)

- 2) Attach the rack mount brackets to both sides of the rack, and tighten with six screws.

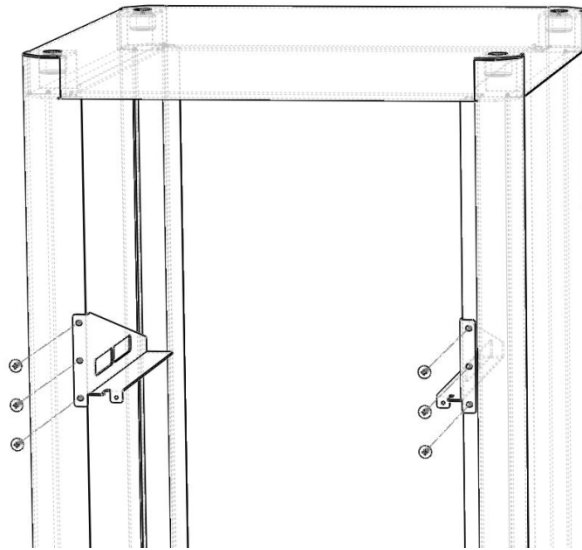

Figure 5.8 OS 7150 Installation in a Rack (2)

- 3) Guide the OS 7150 unit through the guide rails formed by the rack mount brackets.

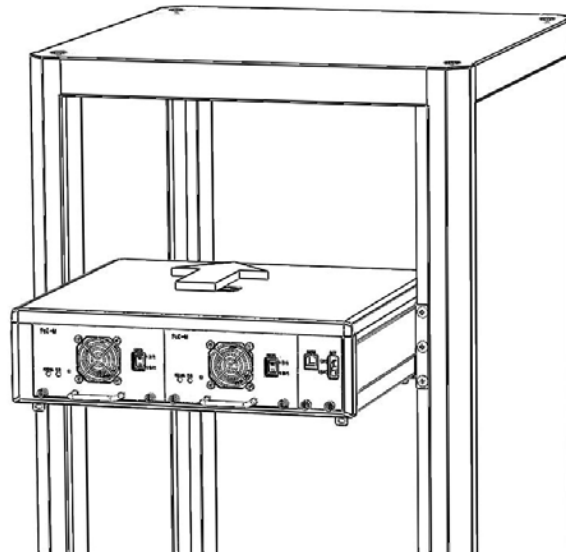

Figure 5.9 OS 7150 Installation in a Rack (3)

- 4) Match the cross bar bracket attached to the 7150 to the two holes in the bracket inside the rack properly and then tighten with screws.

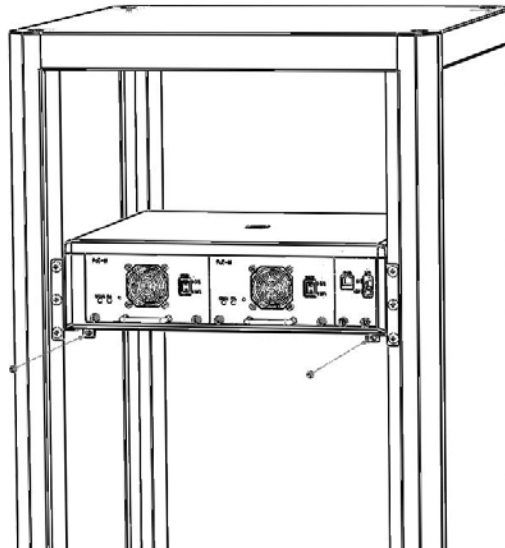

Figure 5.10 OS 7150 Installation in a Rack (4)

INSTALLATION ON THE FLOOR



Observe the following requirements to install OfficeServ 7150 on the floor:

- Install the system at a place with good air ventilation and no humidity.
- Do not block the front fan of the OfficeServ 7150.
- Do not block the rear air ventilation of the OfficeServ 7150.

GROUND WIRE CONNECTION

This section describes how to connect external grounding wire to the OfficeServ 7150.



[Follow the grounding conditions and guidelines in Section 1.2 for grounding the OfficeServ 7150.](#)

As shown in the following illustration, connect the grounding wire to the grounding lug at the rear of the OfficeServ 7150 cabinet.

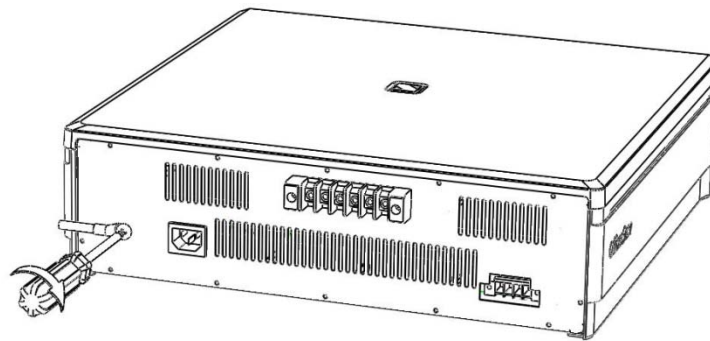

Figure 5.11 OS 7150 Grounding

CONNECTING POWER

Connecting an External Battery



A battery can be connected to the 7150 so in case of a power failure, the unit will continue normal operation attaining power from the battery. Battery capacity should be DC48V, 45AH or lower. Before connecting the battery to the 7150, turn OFF power to the system.

Observe the following safety requirements when connecting an external battery to the system:



- Disconnect and turn off all power to the 7150 before connecting the battery.
- Disconnect any connections to an OfficeServ 7200 system.
- Pay attention to polarity (+,-) orientation of the battery when connecting to the system.

- 1) A battery cable comes with the OfficeServ 7150 cabinet. One end of the battery cable is a green keyed plastic connector. The other end is made up of a red wire and a blue wire.
- 2) Connect the green connector into the battery connection port of the OfficeServ 7150. The connector is keyed so you can only insert it in one way. Press it in until it is pushed in all the way ([see Figure 5.12](#)). At the other end of the battery cable, connect the red wire to the (+) positive terminal lug of your battery, and connect the blue wire to the (-) negative terminal lug of your battery.

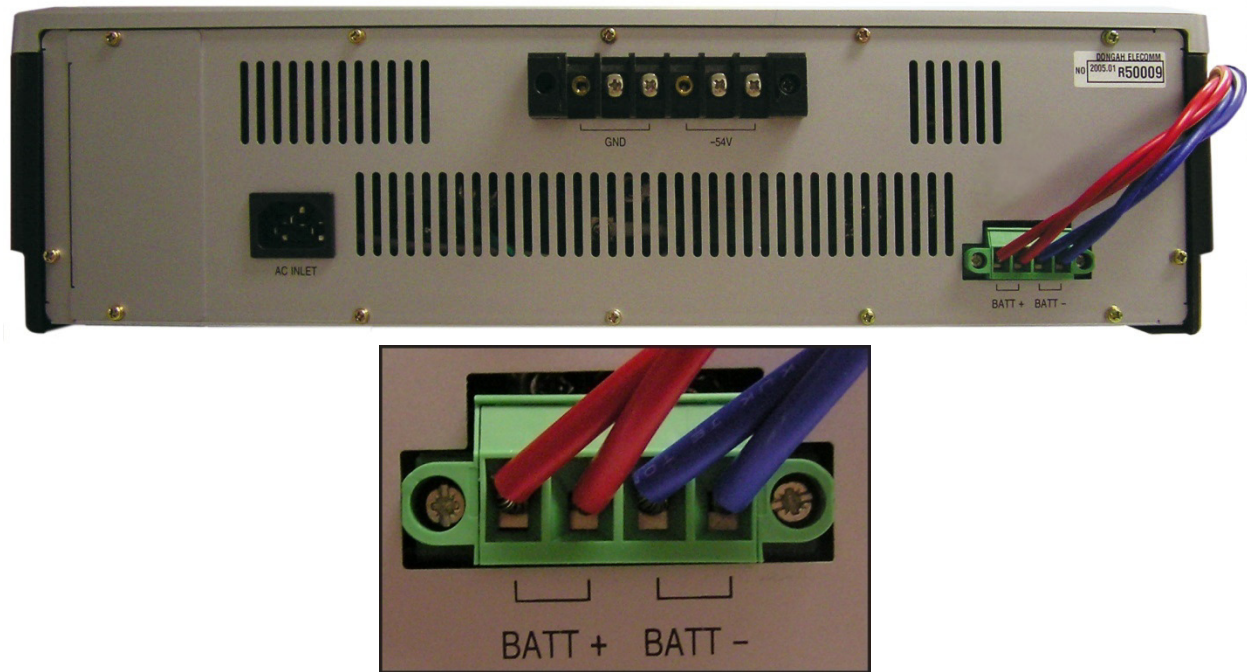

Figure 5.12 Connecting an External Battery



Safety Tips in Connecting External Battery Cable

As the OfficeServ 7150 is a high output power supply system, a maximum of DC48V 30A may be flown from the battery. Do not use cables other than the one that comes with this product.

Connecting AC Power Source



While input power is normal, AC voltage is fed to the power supply system while charging an external battery. If input power failure occurs, the power from the battery will maintain normal operation of the 7150 PSU.



Observe the following safety tips when a power source is connected to the OfficeServ 7150:

- As the system supports both AC 110 and 220V, do not change the factory settings set for your country.
- This system shall use an AC outlet exclusively. Do NOT share the AC outlet with other electric devices. Doing so may cause system malfunction or fire caused by electrical noise or voltage drop.

- Instantaneous power failure may cause system mal-function or battery failure. Therefore use a stable supply of AC power.
- Using the power cable that comes with the OfficeServ 7150 system, connect the power input port at the rear of the cabinet to a grounded electric outlet.

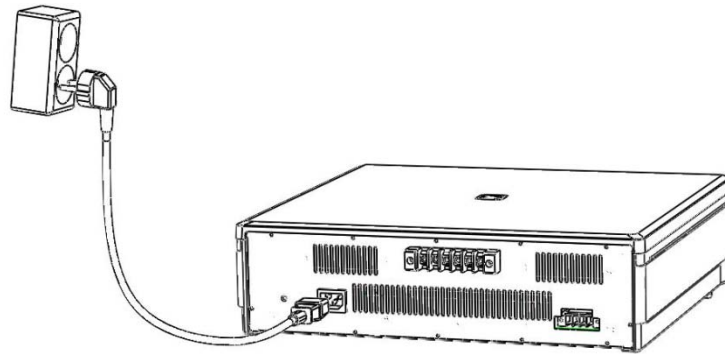

Figure 5.13 Power Connection

CONNECTING THE 7150 TO THE OFICESERV 7200 [\(See Figure 5.14\)](#)

- 1) Make sure All AC power and battery connections to the OfficeServ 7150 and OfficeServ 7200 are disconnected before proceeding.
- 2) Connect the plastic connector end of the PoE cable into the back of the OfficeServ 7200 connector labeled "PoE Input".
- 3) The other ends of the PoE cable will have a Red wire and a Blue wire. Connect the Red wire to the first GND lug from the left on the back of the 7150. Connect the Blue wire to the first -54V lug from the left on the back of the 7150.
- 4) If connection to a second OfficeServ 7200 cabinet is required, then repeat the steps above and connect the red wire to the 2nd GND lug from the left and the blue wire to the second +54V lug from the left.
- 5) Power on the 7200 cabinets.
- 6) Power the OS 7150 ON by turning on the power switches on each PoE-M PSU modules and if a battery is connected, turn on the BATT switch to the ON position on the front of the 7150.

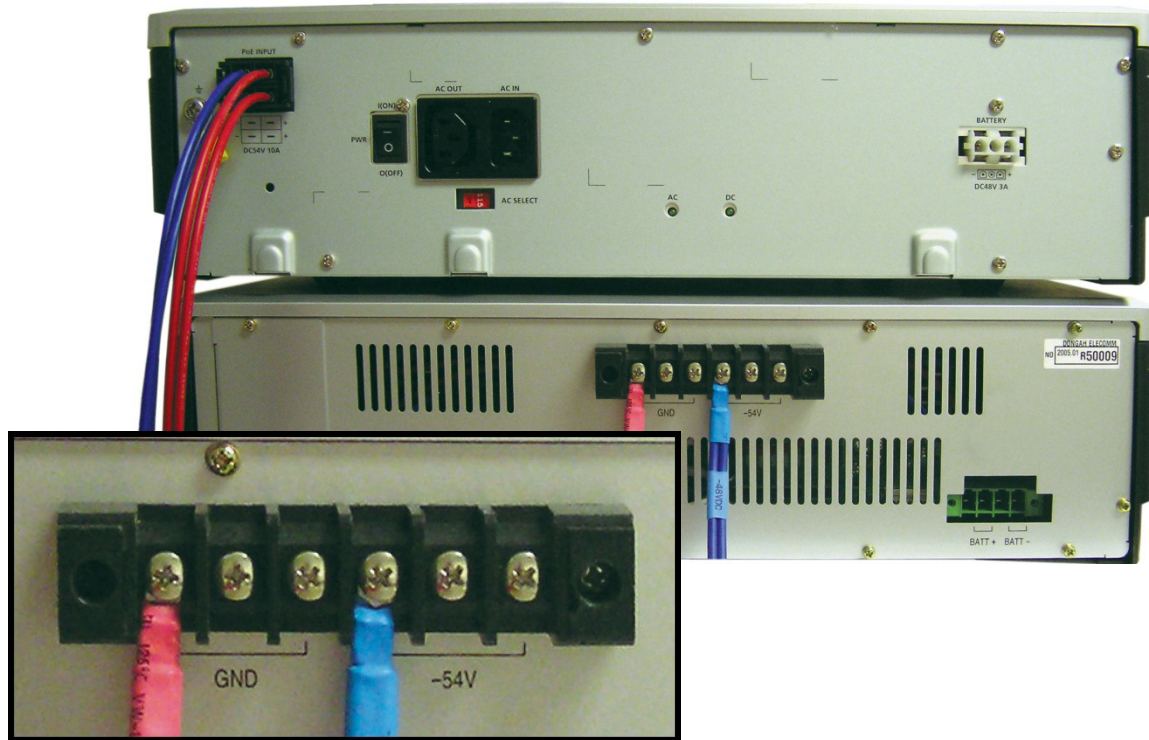

Figure 5.14 Connecting OS 7150 to OS 7200

SPECIFICATIONS OF OFFICESERV 7150

Specifications of Cabinet

Table 5.2 Input Voltage and Frequency

INPUT VOLTAGE & FREQUENCY	
Rated AC Input Voltage	Single phase AC 110/220VAC
Range of Allowable AC Input Voltage	88VAC ~ 264VAC
Rated AC Input Frequency	50/60 Hz
Range of Allowable AC Input Frequency	47Hz ~ 63Hz

Rated Output

Table 5.3 Rated Output in the Case of Operation with AC

RATED OUTPUT IN THE CASE OF OPERATION WITH AC	
1 Module	DC -54V, 7.5A
2 Module	DC -54V, 15.0A
Battery	DC 54V, 0.45A

Table 5.4 Rated Output in the Case of Operation with DC

RATED OUTPUT IN THE CASE OF OPERATION WITH DC	
1 Module	Battery By-pass (DC 48V,48AH or lower), 7.5A
2 Module	Battery By-pass (DC 48V,48AH or lower), 15.0A

Integration of Modules

Modules may share load among them and module swapping is also possible.

PART 6. CONNECTING C.O. LINES

This section describes how to connect C.O. lines to the OfficeServ 7200 system after installation.

6.1 SAFETY PRECAUTIONS

To reduce the risk of personal injury, follow these precautions before connecting TELCO circuits:

- Wires with AWG #24 or AWG #26 width should be used as subscriber lines.
- Never touch non-insulated telephone wires or terminals unless the telephone line has been disconnected at the Network Interface.
- When wiring cables in high-humidity areas, remove moisture before wiring.
- Never install telephone jackets in a wet location unless the jack is specifically designed for wet locations.
- Wires should be handled carefully to prevent any changes or damages.
- Subscriber lines should be kept indoors if possible.
- High voltage power lines should not be wired near a subscriber line.
- Never install telephone wiring during a lightning storm.

Leak resistance for C.O. lines connected to the OfficeServ 7200 system is as follows:

Table 6.1 OfficeServ 7200 Line Conditions

Line Condition	Leak Resistance
Leak Resistance Between Lines	20 k Ω or higher
Leak Resistance Between Grounds	20 k Ω or higher

6.2 CONNECTING C.O. LINES

6.2.1 Connecting Analog Loop Start Lines

Use a twisted pair (AWG #24 (or AWG #26) wire or cord to connect an analog loop start C.O. line to pins 4 & 5 of the RJ45 jack on the 8TRK/8TRK2/16TRK or 4TRM installed in the OfficeServ 7200 system.

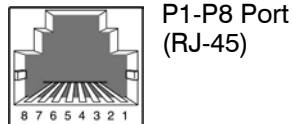

Pin No.	1	2	3	4	5	6	7	8
Function	-	-	-	C.O. TIP	C.O. RING	-	-	-

Figure 6.1 TIP and Ring connections to Analog Trunk Cards

6.2.2 Connecting T1/E1/PRI

TEPRI/TEPRIa/TEPRI2 boards can be connected to a T1/E1 C.O. circuit through a RJ-45 port. As show below, connect a T1/PRI circuit to the T1/E1/PRI port of the OfficeServ 7400 system. Though the TEPRI board supports E1, it is not used in the USA.

Using a standard, straight through eight conductor data cable or straight through eight conductor line cord to connect the customer provided Channel Service Unit (CSU) to the TEPRI/TEPRIa/TEPRI2 card as shown in [Figure 6.2](#).

NOTES:

1. It may be necessary to cut off the CSU end of the cable and attach a different connector to match that of the CSU. If possible, this connection should be soldered because good connections are critical.
2. It is recommended that the CSU be connected to the network interface with a cable supplied by the CSU manufacturer. If this is not possible or practical, a custom cable has to be made up. This cable should be made from 22 gauge two pair cable with each pair individually shielded. It is recommended that the connections on this cable be soldered wherever possible to ensure good connections. The shielding of the cable should be connected to ground at the CSU end only to prevent a ground loop.

ORDERING A T1

The following information may be useful when ordering T1 service from the telephone company.

PARAMETERS supported on OfficeServ all TEPRI cards

FRAMING	T1 Circuit	PRI Circuit
Super Frame (D4 56K Frame)	Yes	Not Supported
Extended Super Frame (ESF 64K Frame)	Yes	Yes
CODING	T1 Circuit	PRI Circuit
AMI - 56K Coding	Yes	Not Supported
B8ZS - ESF 64k Coding	Yes	Yes
NFAS (Non Facility Associated Signaling)	Not Supported	Not Supported

Use MMC 808 to set the parameters to match the Telco T1 span.

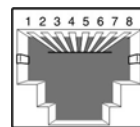

T1/PRI Port
(RJ-45)

T1/E1/PRI Port

Pin No.	1	2	3	4	5	6	7	8
T1/PRI Function	Rx+	Rx-	-	Tx+	Tx-	-	-	-
E1 Function	NOT SUPPORTED IN USA							

Figure 6.2 RJ-45 Port of TEPRI/TEPRIa Board

6.2.3 Connecting a SIP Trunk

There is no physical SIP trunk card required to use the SIP trunking service. However, in order to use the SIP trunking service, the OfficeServ system must be IP-enabled. That means that the OfficeServ system must have an MGI card with the latest MP software and have high speed Internet connection.

Please refer to the "OfficeServ Series SIP Trunking Quick Reference Document" for configuration.

PART 7. CONNECTING STATIONS AND ADDITIONAL EQUIPMENT

This section describes how to connect various stations and additional equipment, such as analog/digital phones, door phones and door locks, to the OfficeServ 7200 system.

7.1 CONNECTING STATIONS

7.1.1 Safety Precautions

To reduce the risk of personal injury, follow these precautions before connecting telephone circuits:

- Never install telephone wiring during a lightning storm.
- Never install telephone jacks in a wet location unless the jack is specifically designed for wet locations.
- Do not connect stations in a humid area.
- Never touch non-insulated telephone wires or terminals unless the telephone line has been disconnected at the network interface.
- Connect stations using #24 AWG or #26 AWG cables.

The maximum distance between stations and the OfficeServ 7200 are as follows:

Table 7.1 Distance Between Stations and the System

Station	Distance
Digital phone	Maximum 400m / 1312ft (for AWG #24)
Analog phone	Maximum 1km / 3280ft (for AWG #24)
Door phone	Maximum 400m / 1312ft (for AWG #24)
AOM	Maximum 400m / 1312ft (for AWG #24)
WBS24	Maximum 600m / 1968ft (0.64 twisted cable) Maximum 400m / 1312ft (0.40 twisted cable)

7.1.2 Connecting an Analog Phone

Connect an analog phone to the 8SLI/8SLI2, 16SLI2, 16MWSLI, 8COMBO/8COMBO2 boards installed in the OfficeServ 7200 system.

CONNECTING TO THE 8SLI/8SLI2

Connect an analog phone to the 8SLI/8SLI2 board by using a twisted pair of AWG #24 or AWG #26 wire.

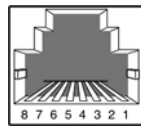

P1~P8 Port
(RJ-45)

P1 port

Pin No.	1	2	3	4	5	6	7	8
Function	PFT TIP	PFT RING	-	SLI TIP	SLI RING	-	-	-

P2-P8 port

Pin No.	1	2	3	4	5	6	7	8
Function	-	-	-	SLI TIP	SLI RING	-	-	-

Figure 7.1 RJ-45 Port of the 8SLI

CONNECTING TO THE 16SLI2/16MWSLI

Connect an analog phone to the 16SLI2/16MWSLI board by using a twisted pair of AWG #24 or AWG #26 wires.

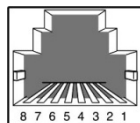

P1~P16 Port
(RJ-45)

P1 Port

Pin No.	1	2	3	4	5	6	7	8
Function	PFT TIP	PFT RING	-	SLI 1 TIP	SLI 1 RING	-	-	-

P2-P16 Port

Pin No.	1	2	3	4	5	6	7	8
Function	-	-	-	SLI 2 TIP	SLI 2 RING	-	-	-

Figure 7.2 RJ-45 Port of the 16SLI2

CONNECTING TO THE 8COMBO/8COMBO2

Connect an analog phone to the 8COMBO/8COMBO2 board by using a twisted pair of AWG #24 or AWG #26 wires.

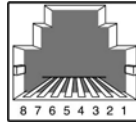

S1-S8 Port
(RJ-45)

S1-S8 Port

Pin No.	1	2	3	4	5	6	7	8
Function	-	-	-	SLI TIP	SLI RING	-	-	-

Figure 7.3 RJ-45 Port of the 8COMBO/8COMBO2 (For Analog Phone)

7.1.3 Connecting a Digital Phone

Connect a digital phone to 8DLI, 16DLI2 or 8COMBO/8COMBO2 boards.

CONNECTING TO 8DLI

Connect a digital phone to the 8DLI board by using a twisted pair AWG #24 or AWG #26 wires.

P1-P8 Port

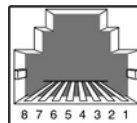

P1~P8 Port
(RJ-45)

Pin No.	1	2	3	4	5	6	7	8
Function	-	-	-	DLI TIP	DLI RING	-	-	-

Figure 7.4 RJ-45 Port of the 8DLI (For Digital Phone)

CONNECTING TO 16DLI2

Connect a digital phone to the 16DLI2 board by using a twisted pair of AWG #24 or AWG #26 wires.

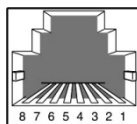

P1~P16 Port
(RJ-45)

P1-P16 Port

Pin No.	1	2	3	4	5	6	7	8
Function	-	-	-	DLI TIP	DLI RING	-	-	-

Figure 7.5 RJ-45 Port of the 16DLI2 (For Digital Phone)

CONNECTING TO 8COMBO/8COMBO2

Connect a digital phone to the 8COMBO/8COMBO2 board by using a twisted pair of AWG #24 or AWG #26 wires.

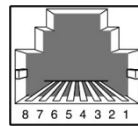

D1~D8 Port
(RJ-45)

Pin No.	1	2	3	4	5	6	7	8
Function	-	-	-	DLI TIP	DLI RING	-	-	-

Figure 7.6 RJ-45 Port of the 8COMBO/8COMBO2 (For Digital Phone)

7.1.4 Connecting an IP Phone

[Refer to the ITP-5121D Keyset User Guide, ITP-5112L Keyset User Guide, ITP-5107S Keyset User Guide, SMT-i3105 User Guide, SMT-i5210 User Guide, SMT-i5220 User Guide, SMT-i5230 User Guide, and SMT-i5243 User Guide for information on connecting IP keysets.](#)

CAUTION: The input power of the SMT-i Series phones needs 5.0vDC and 3000mA. The SMT-i5210, SMT-i5220, SMT-i5230, and SMT-i5243 need to be powered by using Samsung’s SMT-A53PW power adapter. The SMT-i3105 requires the SMT-A53PA power adapter. Failure to use the appropriate power supply will cause permanent damage to the phone and will void Samsung’s warranty.

7.1.5 Connecting SIP Stations

There is no physical SIP station card required to use the SIP station service. In order to use a generic (non-Samsung) SIP device (phone, softphone, terminal adapter), the OfficeServ system must be IP-enabled. This means the OfficeServ system must have a SIP Stack License key, MGI channels virtual ports, MGI channels, with the latest software MP software, and have a high speed internet connection. Please refer to the “OfficeServ Series SIP Station Quick Reference Document” for more detailed information about configuring the OfficeServ SIP Server.

7.1.6 Connecting Cards to LAN

WIM/PLIM/PLIM2/GSIMT/GPLIMIT/4DSL/MGI-16/MGI/MCP/MP20/SVMi-20E/OAS boards can be connected to a LAN by using an Ethernet cable.

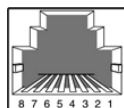

RJ-45
port

Pin No.	1	2	3	4	5	6	7	8
WIM/MCP/MP20/MGI-16/ MGI/4DSL/ SVMi-20E/OAS	Tx+	Tx-	Rx+	-	-	Rx-	-	-

Pin No.	1	2	3	4	5	6	7	8
PLIM/PLIM2	Rx+	Rx-	Tx+	-	-	Tx-	-	-
GSIMT/GPLIMT								

Figure 7.7 LAN Connections

- WIM board-P1, P2, P3, and P4 ports
- PLIM/PLIM2 board-all ports (P1 through P16)
- GSIMT P1~P12
- GPLIMT P1~P12
- 4DSL board-Up Link port(LAN)
- MCP/MP20, MGI, MGI16 and SVMi-20E boards-LAN port

7.1.7 Connecting a Wireless LAN Access Point

Wireless LAN service offered by the OfficeServ 7200 system requires the following equipment:

- 4WLI board: A board installed in the OfficeServ 7200 system for WBS24 connection
- WBS24: Wireless LAN Access Point (AP)
- WIP-5000M: Wireless LAN IP phone

Table 7.2 Specification for Wireless LAN Connection

Item	OfficeServ 7200 System	
	Main Cabinet	Main and Expansion Cabinets
Number of the 4WLI boards	3	3
Maximum number of WBS24s	12	12
Maximum number of users	120	120
Number of simultaneous users	48	48



NOTE

References

For information on how to install and use WBS24 and WIP-5000M, refer to OfficeServ Wireless Documentation.

Connect the 4WLI board and WBS24 by using two 0.64 mm twisted cables (RJ-45 Ethernet cable, 600 m/1968 ft maximum distance) or two 0.40 mm twisted cables (RJ-45 Ethernet cable, 400 m/1312 ft maximum distance).

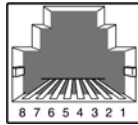

P1~P4 ports
 (RJ-45)

Pin No. of WBS24 Port	WBS24 No.	Signal	Pin No. of 4WLI Port
4	1	D channel data	4
5			5
3		Sync line	3
6			6
4	2	D channel data	4
5			5
3		Sync line	3
6			6
4	3	D channel data	4
5			5
3		Sync line	3
6			6
4	4	D channel data	4
5			5
3		Sync line	3
6			6

Figure 7.8 RJ-45 Port of 4WLI

7.1.8 Connecting a Dual-Band AP-SMT-R2000

Please refer to the "OfficeServ Wireless Quick Reference Document".

7.1.9 Connecting a Door Phone and a Door Lock

Connect a door phone and a door lock to the OfficeServ 7200 system using a Door Phone Interface Module (DPIM).

- 1) Connect the Door Phone Interface Module (DPIM) line jack to any DLI port in the OfficeServ 7200 system using twisted pair (24AWG/26AWG). Use MMC 211 to assign a directory number to the doorphone. [See figure 7.9.](#)
- 2) Connect the Door Phone to the DPIM-door box jack using 4 conductor twisted pair cable. [See figure 7.9](#) for power and voice pair pin assignments.
- 3) If required connect a custom provided door lock to the lock contact pair on the DPIM using twisted pair wire (24/26 AWG) as indicated in [figure 7.9.](#)

The door lock contact pair is designed to control a low-voltage relay rated at 24VDC and 100mA. Do not attempt to connect commercial AC power to these contacts.



NOTE

MMC

[MMC 211](#) is used to assign call numbers to door phones. Use [MMC 501](#) to program duration of contact closure. [For detailed instruction on the MMC program, refer to OfficeServ 7200 Programming Section.](#)

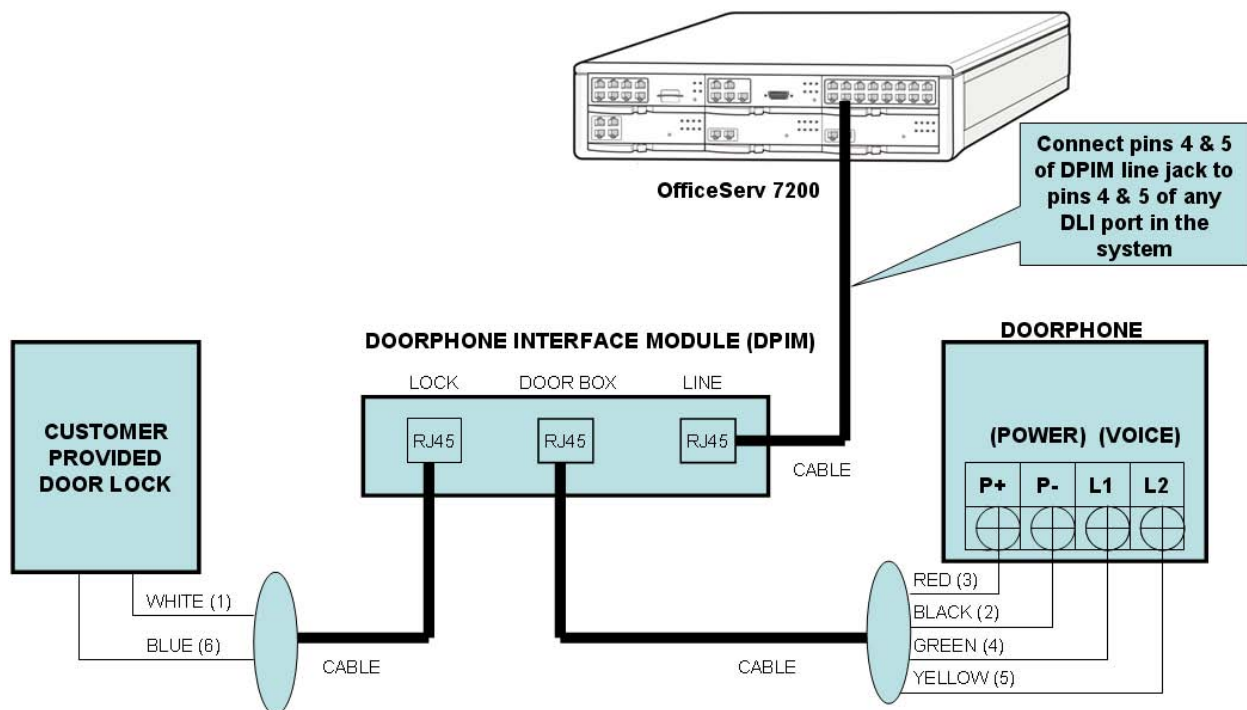

Figure 7.9 Connecting a Door Phone and a Door Lock

7.1.10 Connecting KDB-D/KDB-S

KDB-D and KDB-S are modules installed on a digital phone connected to the OfficeServ 7200 system. The KDB module enhances the functions of the phone and increases the number of local ports according to module types.



Caution for connecting KDB module

KDB-D and KDB-S is only for a digital phone connected to the 8DLI board, not for a digital phone connected to a 16DLI2 board.

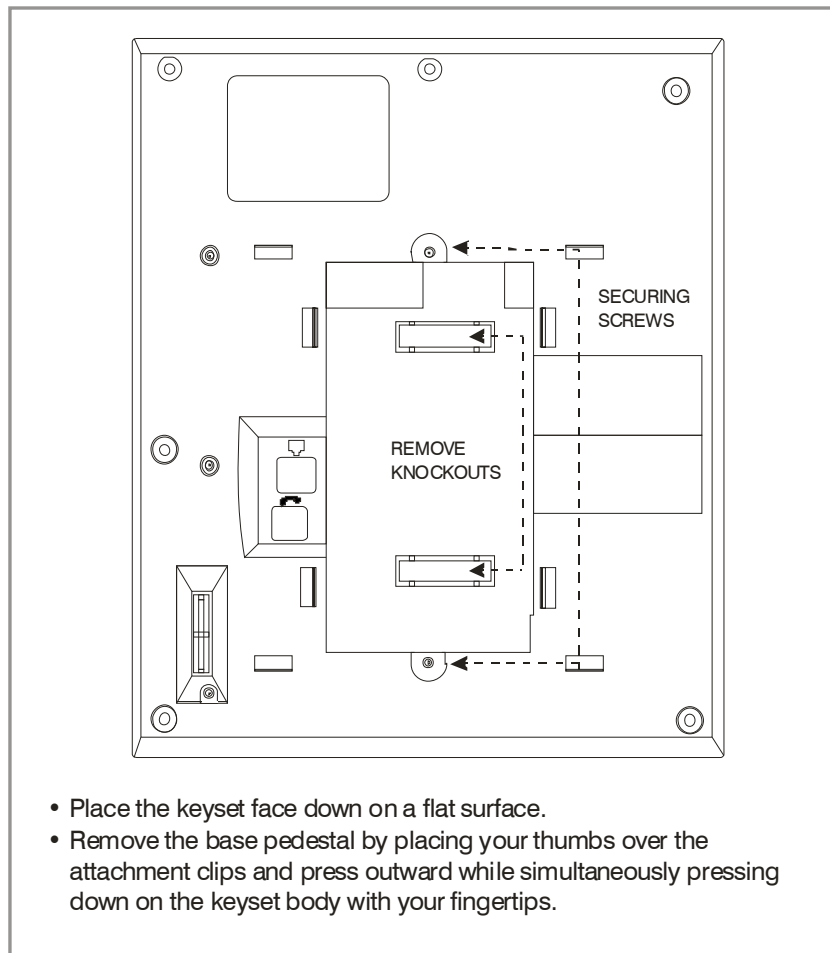

Figure 7.10 Adding an iDCS Keypad Daughterboard Module

iDCS KDB-DIGITAL LINE INTERFACE (FKDBD)

This is a daughterboard that can be installed only in the 18 or 28 button keypad. The FKDBD will provide one additional DLI circuit for the connection of any digital station device such as a keypad, add-on module or DPIM. This FKDBD will only operate when the keypad is connected to an 8 port DLI card so it can use the second B channel. Each port on this card is intended for

connection to one telephone. Connecting multiple telephones to a port may result in incorrect operation or damage to the card. [See Figure 7.13.](#)

iDCS KDB-SINGLE LINE INTERFACE (FKDBS)

This is a daughter board that can be installed only in the 18 or 28 button keyset. The FKDBS will provide one additional SLI circuit for the connection of any standard telephone device. This FKDBS will only operate when the keyset is connected to an 8 port DLI card it can use the second B channel. Each port on this card is intended for connection to one telephone. Connecting multiple telephones to a port may result in incorrect operation or damage to the card. [See Figure 7.10.](#)

NOTE: The circuitry on a FKDBS does not provide a loop open disconnect signal or have the over-voltage protection necessary for OPX operation.

iDCS KDB-FULL DUPLEX (FKDBF)

The standard speakerphone mode of operation for a iDCS keyset is “half duplex”. This means that you cannot transmit and receive speech at the same time. Adding a FKDBF to your keyset will convert the speakerphone into full duplex mode enhancing its operation. In addition the FKDBF may have up to 3 external microphones attached to it for conference room type applications. These microphones require an “EXTMIC” key programmed on the keyset to activate or deactivate them. [See Figure 7.10.](#)

DS KDB-FULL DUPLEX (KDBF)

This is a daughterboard that can only be installed in the 21D or 14D button keysets. The standard speakerphone mode of operation for a DS keyset is “half duplex”. This means that you cannot transmit and receive speech at the same time. Adding a KDBF to your keyset will convert the speakerphone into full duplex mode enhancing its operation. In addition the KDBF may have up to 3 external microphones attached to it for conference room type applications. These microphones require an “EXTMIC” key programmed on the keyset to activate or deactivate them. [See Figure 7.11.](#)

KDB-DLI

This daughterboard can be installed only in the DCS 12 or DCS 24 button keyset. Before performing this procedure, unplug the line cord from the keyset and remove the base wedge. Place the keyset face down on a soft surface and remove the four base retaining screws ([see Figure 7.11](#)). Separate the base from the keyset and place the keyset aside. Attach the KDb-DLI to the keyset base with the four screws that are supplied ([see Figure 7.12](#)). Take care to ensure that the modular socket shows through the access hole in the base ([see Figure 7.13](#)). Invert the base assembly over the keyset and plug the ribbon cable into the socket on the keyset PCB ([see Figure 7.14](#)) while making sure that no damage occurs to the keyset PCB. Reattach the base to the keyset and test to ensure normal keyset operation.

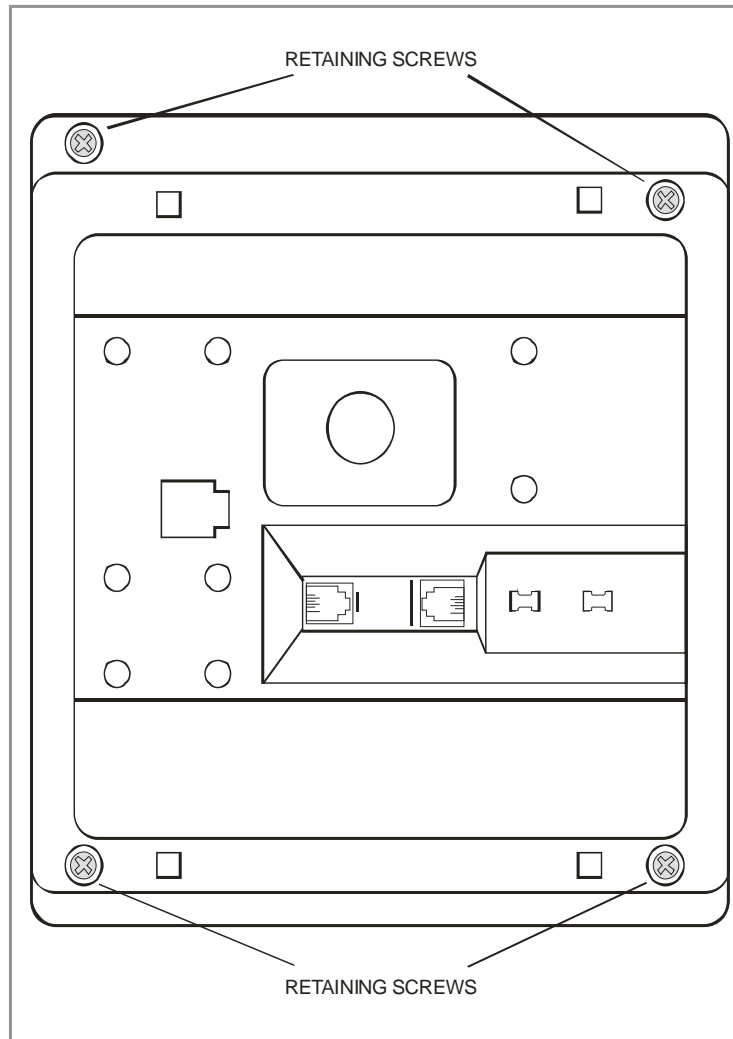

Figure 7.11 Keypad Base

KDB-SLI

This daughterboard can be installed only in the DCS 12 or DCS 24 button keyset. Before performing this procedure, unplug the line cord from the keyset and remove the base wedge. Place the keyset face down on a soft surface and remove the four base retaining screws ([see Figure 7.11](#)). Separate the base from the keyset and place the keyset aside. Attach the KDb-SLI to the keyset base with the six screws that are supplied ([see Figure 7.15](#)). Take care to ensure that the modular socket shows through the access hole in the base ([see Figure 7.13](#)). Invert the base assembly over the keyset and plug the ribbon cable into the socket on the keyset PCB ([see Figure 7.14](#)) while making sure no damage occurs to the keyset PCB. Reattach the base to the keyset and test to ensure normal keyset operation.

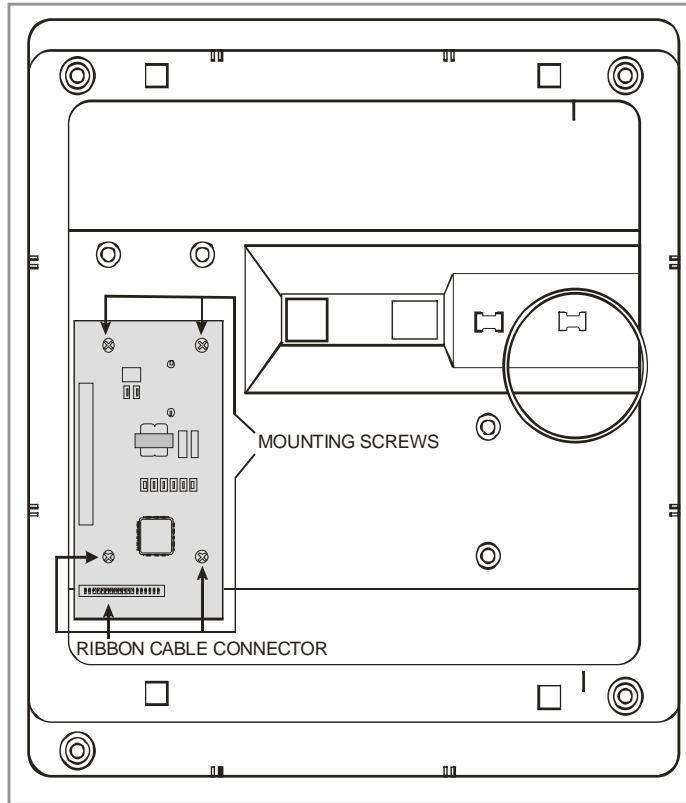

Figure 7.12 Installing KDB-DLI Daughterboard

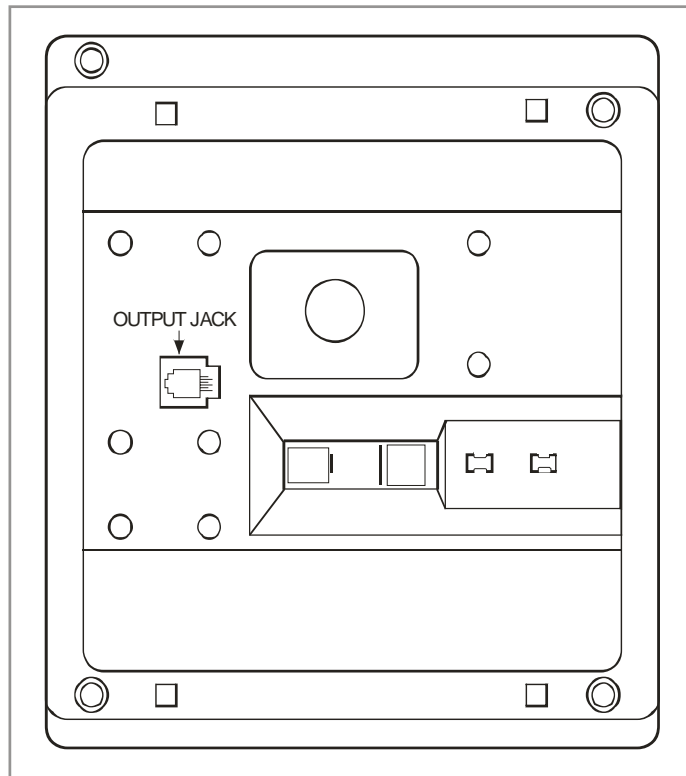

Figure 7.13 Keyset Daughterboard Output Jack

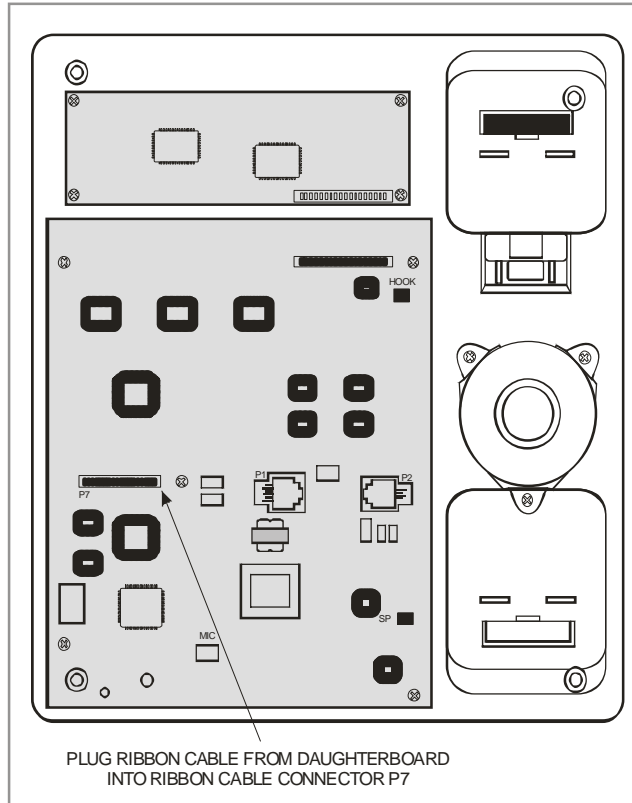

Figure 7.14 Connecting Keyset Daughterboard to Keyset PCB

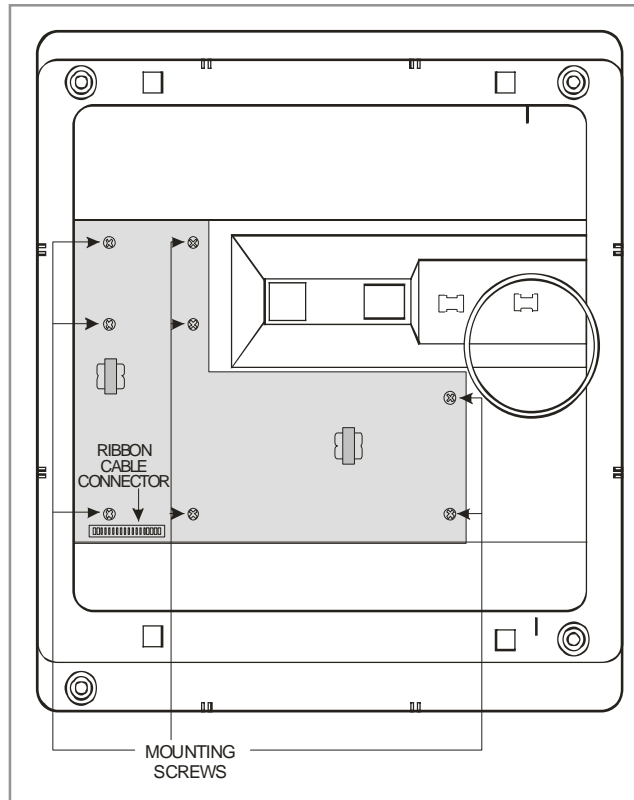

Figure 7.15 Installing KDB-SLI Daughterboard

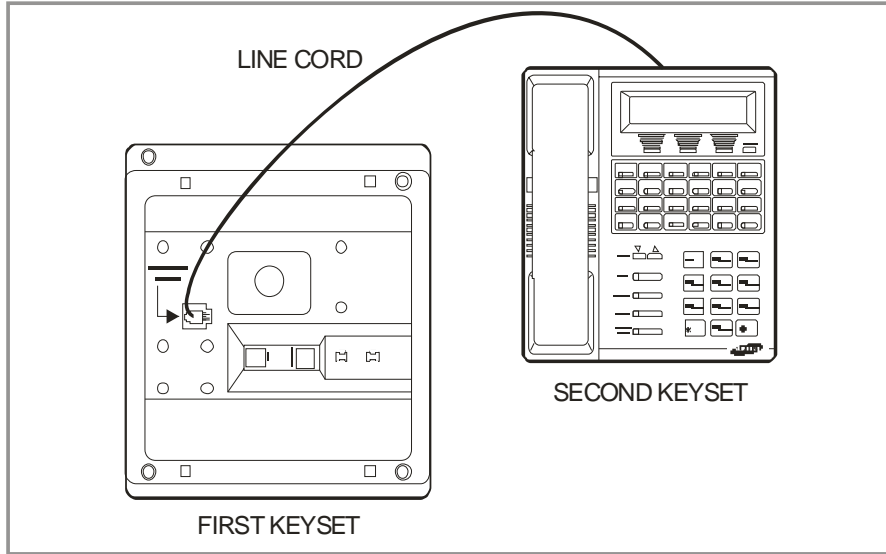

Figure 7.16 Connecting a Keyset to a KDB-DLI

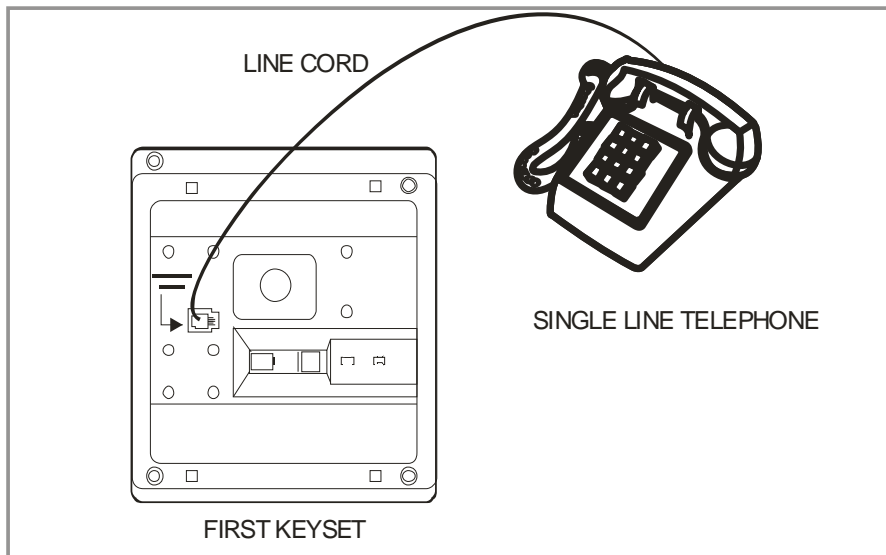

Figure 7.17 Connecting a Single Line Telephone to a KDB-SLI

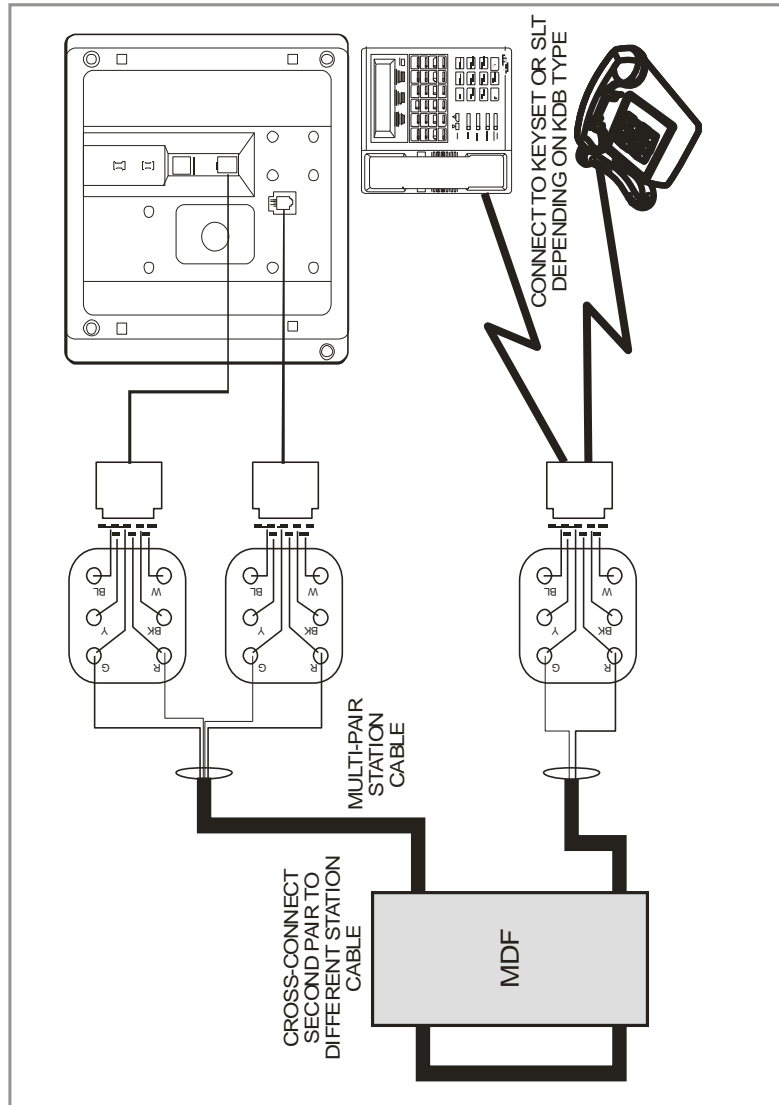

Figure 7.18 Connecting a Station Device to a KDB via MDF

CONNECTING TO THE KDBS

There are two methods for connecting devices to keyset daughterboards. The simplest method is to connect the second device directly by means of a line cord. [See Figures 7.16 and 7.17.](#)

The second method is to use a multi-pair station cable, connecting separate station jacks to the first two pairs. A line cord can now be connected between the daughterboard and the second jack. This returns the daughterboard port to the MDF for cross-connection to another cable run ([see Figure 7.18](#)).

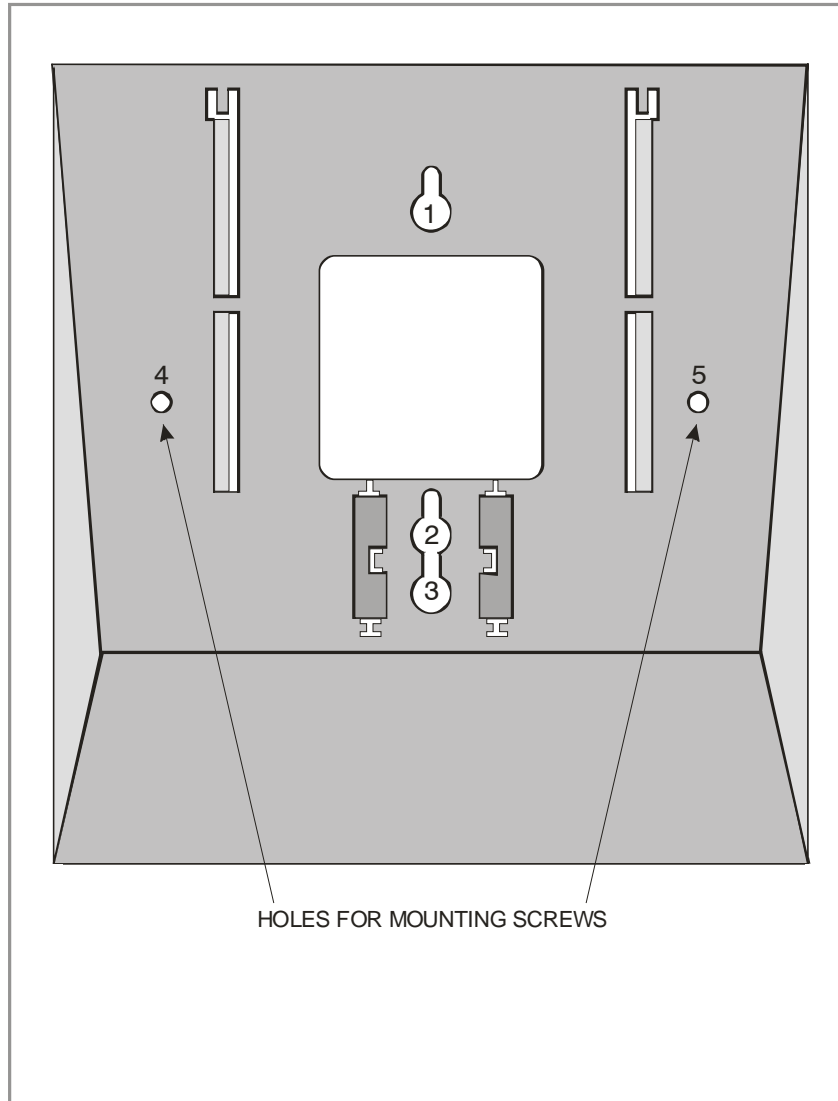

Figure 7.19 Wall-Mounting a Keypad

WALL-MOUNTING KEYSSETS

iDCS keysets come equipped with a reversible base wedge. To wall-mount a keyset, remove the wedge from the keyset and remove the directory tray from the wedge. Mount the wedge to the wall using one of the methods below ([see Figure 7.19](#)).

Use screw holes 1 and 2 to attach the base wedge to a standard electrical outlet box.

OR

Use screw holes 1 and 3 to attach to a standard telephone wall-mount plate with locking pins. This method can cause the keyset to wobble as the keyset feet do not fit securely to the mounting surface.

OR

Use screw holes 4 and 5 if you are mounting on dry wall with a hole in the middle for cable access.

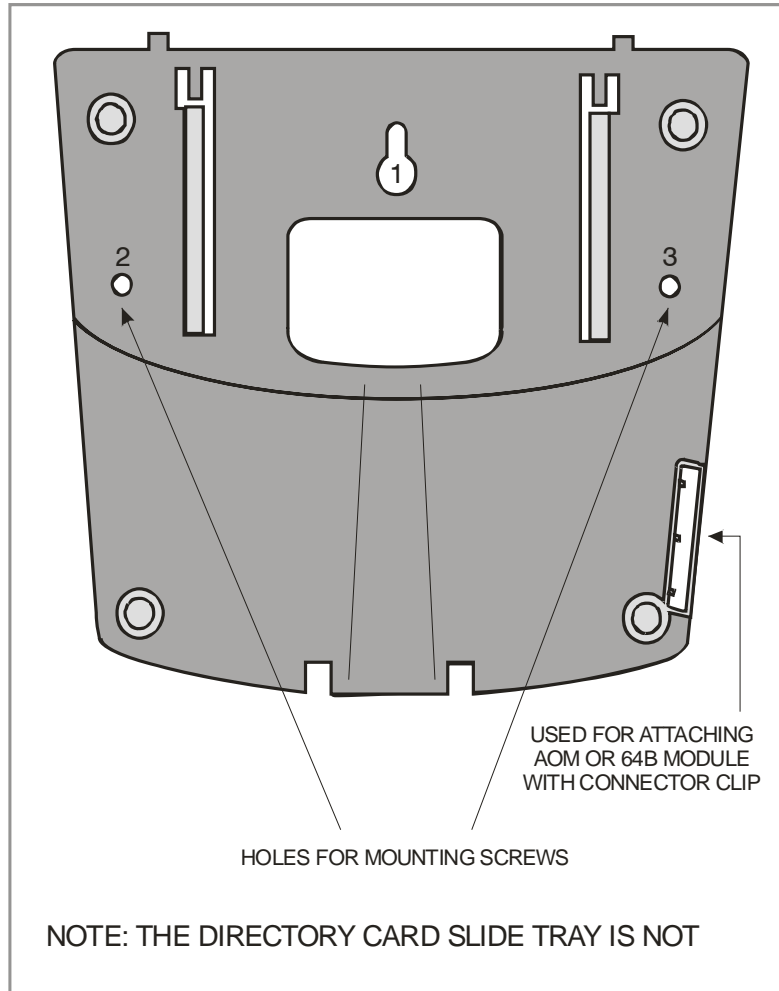

Figure 7.20 Ultra Base Wedge

WALL-MOUNTING KEYSETS WITH ULTRA BASE WEDGE

The keysets now come equipped with a new Ultra Base wedge. These base wedges are reversible and can be used for wall-mounting however not every wall mounting scenario is appropriate. First and foremost there is only one keyhole in the center of the base attaching to the wall, and these base wedges can not be used with the standard wall mount bracket with the two buttons/pins. To wall-mount the keyset using Ultra Base wedges use screw holes 1, 2 and 3 to mount the base wedge on dry wall with the hole in the middle for cable access ([see Figure 7.20](#)).

WALL-MOUNTING iDCS KEYSETS

iDCS keysets come equipped with a reversible base wedge. To wall-mount a keyset, remove the wedge from the keyset and mount the wedge to the wall using one of the methods below ([see Figure 7.21](#)).

Use screw holes 1 and 2 to attach the base wedge to a standard electrical outlet box.

OR

Use screw holes 1 and 3 to attach to a standard telephone wall-mount plate with locking pins. This method can cause the keyset to wobble as the keyset feet do not fit securely to the mounting surface.

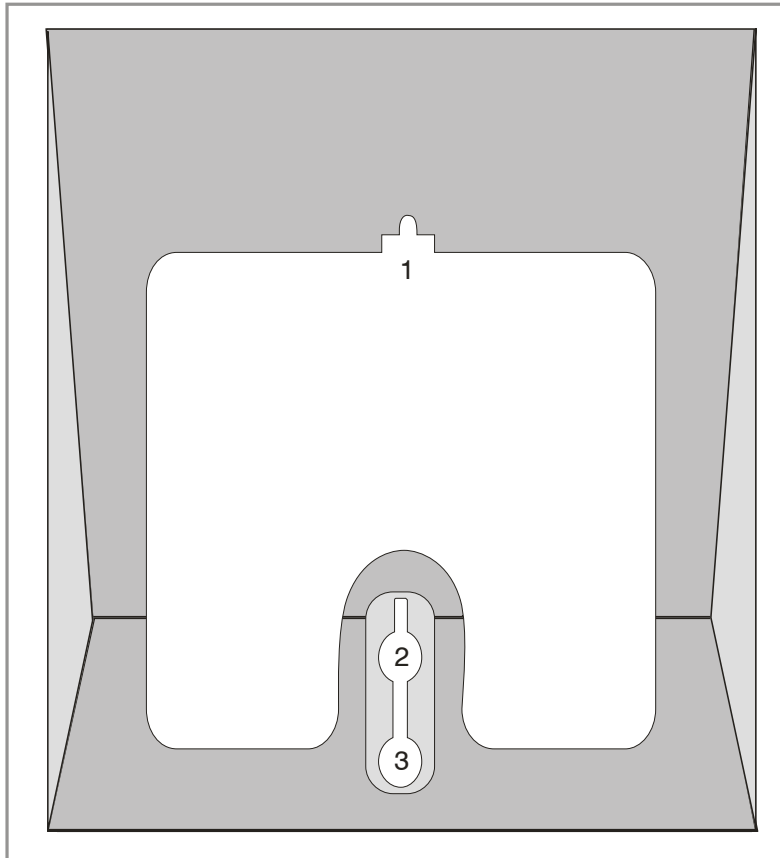

Figure 7.21 Wall-Mounting an iDCS Keyset

WALL-MOUNTING DS, ITP-5121D and ITP-5107S KEYSETS

DS, ITP 5121D and ITP 5107S keysets come equipped with a reversible base stand. To wall-mount a keyset, remove the base stand, reverse it, and attach stand in the bottom slots of the keyset. Use screw holes 1 and 2 to attach the keysets to the wall ([see Figure 7.22](#)).

To secure the handset once you have wall-mounted your keyset you must remove the handset retaining clip and reverse it such that the extended clip is facing the top of the phone ([see Figure 7.22](#)).

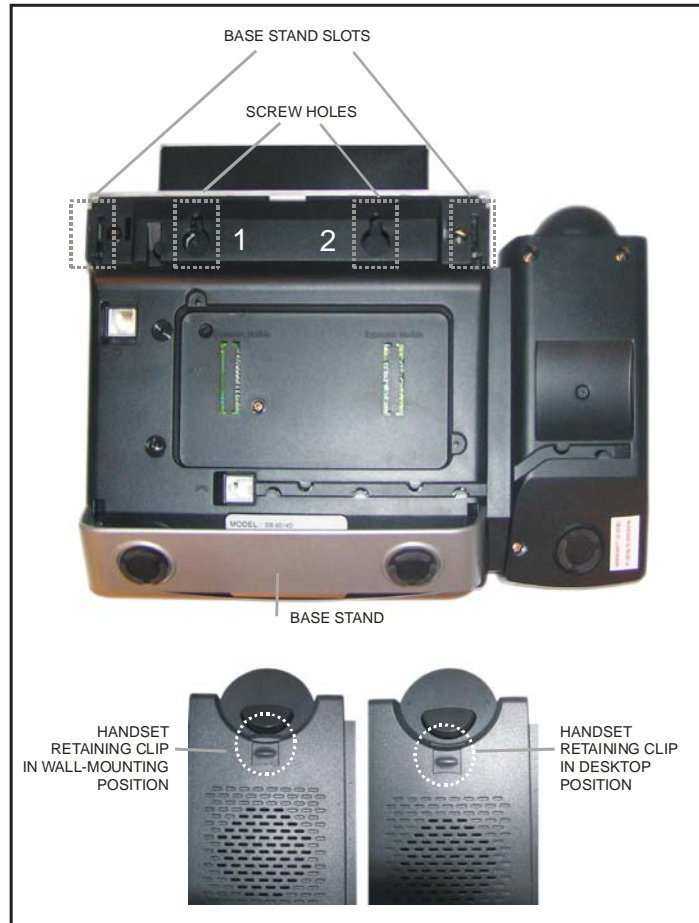

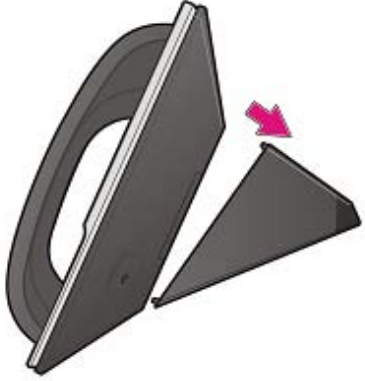

Figure 7.22 Wall-Mounting DS 5000, ITP-5121D and ITP-5107S Keysets

WALL-MOUNTING SMT-i5200 KEYSETS

Assemble the wall-mount bracket where you want to use the phone. The wall-mount bracket is an optional item.

To **install** the wall-mounting bracket follow the steps below:

1. First, choose the location where you want to install the phone, and then determine the positions of the screws by placing the phone at the target location on the wall.

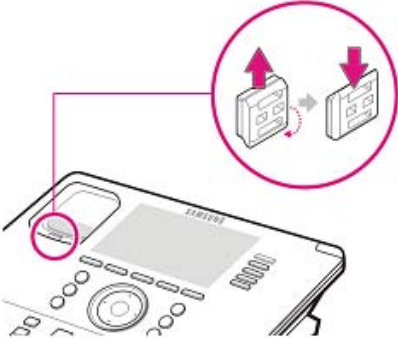
<p>2. Remove the desk cradle of the phone.</p> <ul style="list-style-type: none">a. Fix one latch of the cradle to the top or bottom groove of the phone.b. Push the remaining latch into the remaining groove on the opposite side.	
<p>3. Insert the wall-mount bracket as shown in the figure.</p>	
<p>4. Pull out the handset rack, and then insert it in the opposite direction, as shown in the figure.</p> <p>Only the up-down direction changes. The front-back remains unchanged.</p> <p>5. Install the phone on the wall.</p>	

To detach the wall-mounting bracket follow the steps below:

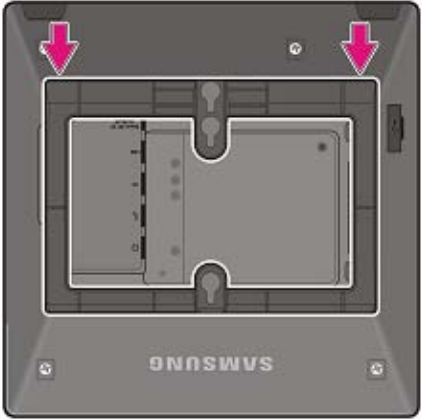
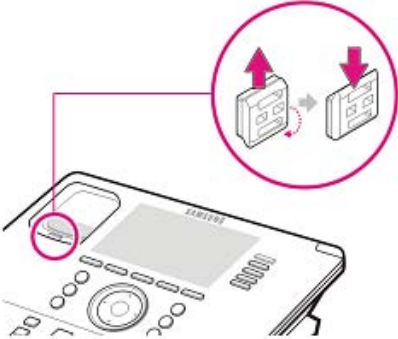
<p>1. You can detach the phone from the bracket by pressing the [Push] section at the bottom of the bracket.</p> <p>Detach the phone more easily by pulling the entire bottom of the bracket instead of only the [Push] section.</p>	
<p>2. Pull out the handset rack, change the direction and then insert it again.</p>	

WALL-MOUNTING SMT-i3105 KEYSETS

The SMT-i3105 keysets do not require an optional wall-mounting bracket.

To wall-mount the SMT-i3105 follow the steps below:

- | |
|---|
| <p>1. First, choose the location where you want to install the phone, and then determine the positions of the screws by placing the phone at the target location on the wall.</p> |
|---|

2. Remove the cradle of the phone by pressing the **[Push]** mark on the top of the cradle to push it out

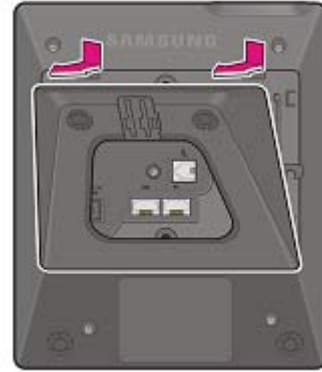

3. Use screw holes 1 and 2 to attach the base wedge to a standard electrical outlet box.

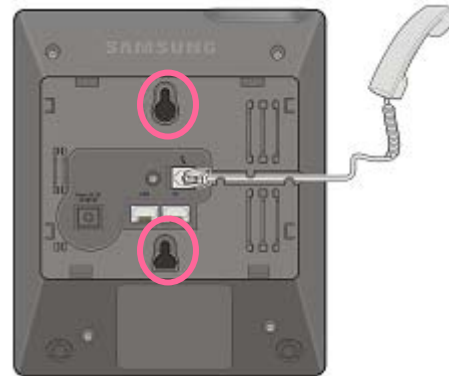

64 BUTTON MODULES

Using one pair twisted #24 AWG or #26 AWG jumper wire, cross-connect each 64 button module (64 BM) to the DLI port or plug into the KDb-DLI of your choice ([see part 7.1.8 of this installation section](#)). The 64 BM module can be assigned to any keyset telephone. It must be assigned to that station in MMC 209.

MAXIMUM AOM CAPACITIES

	Maximum per Station	Maximum per System
TDM 64 Button AOM	4	Limited by available DLI ports
IP 64 Button AOM	4	Limited by available IP/Virtual Ports

CAUTION: To reduce the risk of fire, use only No. 26 AWG or larger telecommunication line cord.

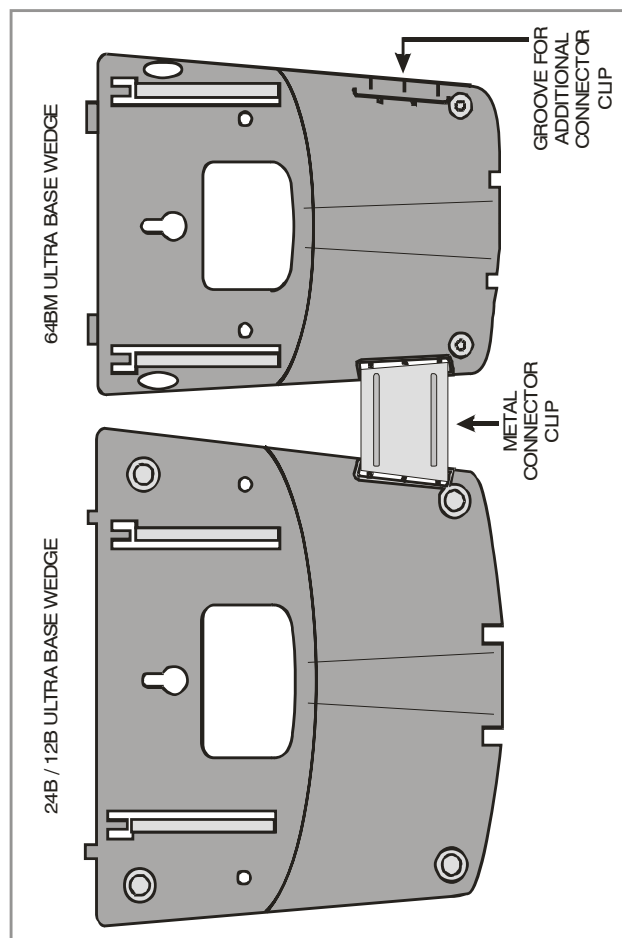

Figure 7.23 Attaching 24B/12B to 64 Button Module

ATTACHING DCS 32 BUTTON AOM AND DCS 64B MODULES WITH MASTER STATION

These new Ultra Base Wedges allow a connector clip (packaged with 64B Modules and AOMs) to be connected to the underside of the new style wedge and attach AOM(s) or 64B module(s) together with the main or "master" station. This "clip" allows multiple 64B modules and or AOMs to be secured or "chained" together to the main or "master" station they are associated with. This will make instruments associated with each other seem as one unit ([see Figure 7.23, Figure 7.24, and Figure 7.25](#)).

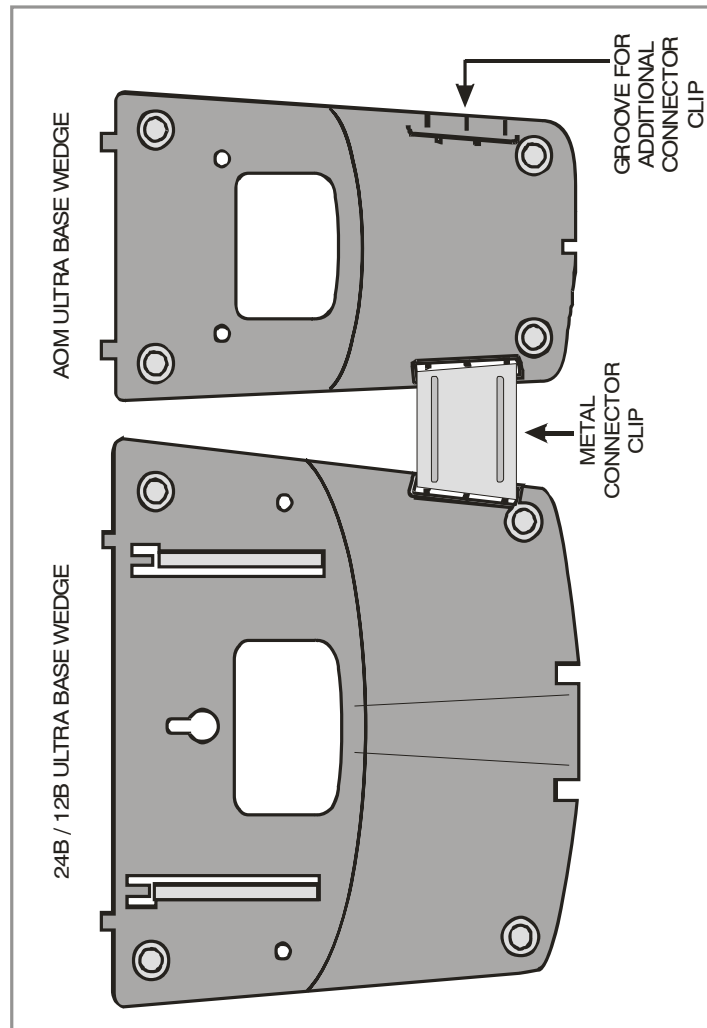

Figure 7.24 Attaching 24B/12B to AOM

ATTACHING iDCS 64 BUTTON MODULES TO AN iDCS KEYSSET

First remove the base wedge from the iDCS 64 Button Module and attach the bracket to it with two of the screws provided ([see Figure 7.26](#)).

Remove the base wedge of the keyset and place it to the right of the 64 Button Module and attach the bracket/64 BM to the keyset with the remaining two screws.

The base wedge can now be replaced.

NOTE: If you wish to attach two 64 button modules to a keyset, connect the 64 button modules together first and then attach them to the keyset.

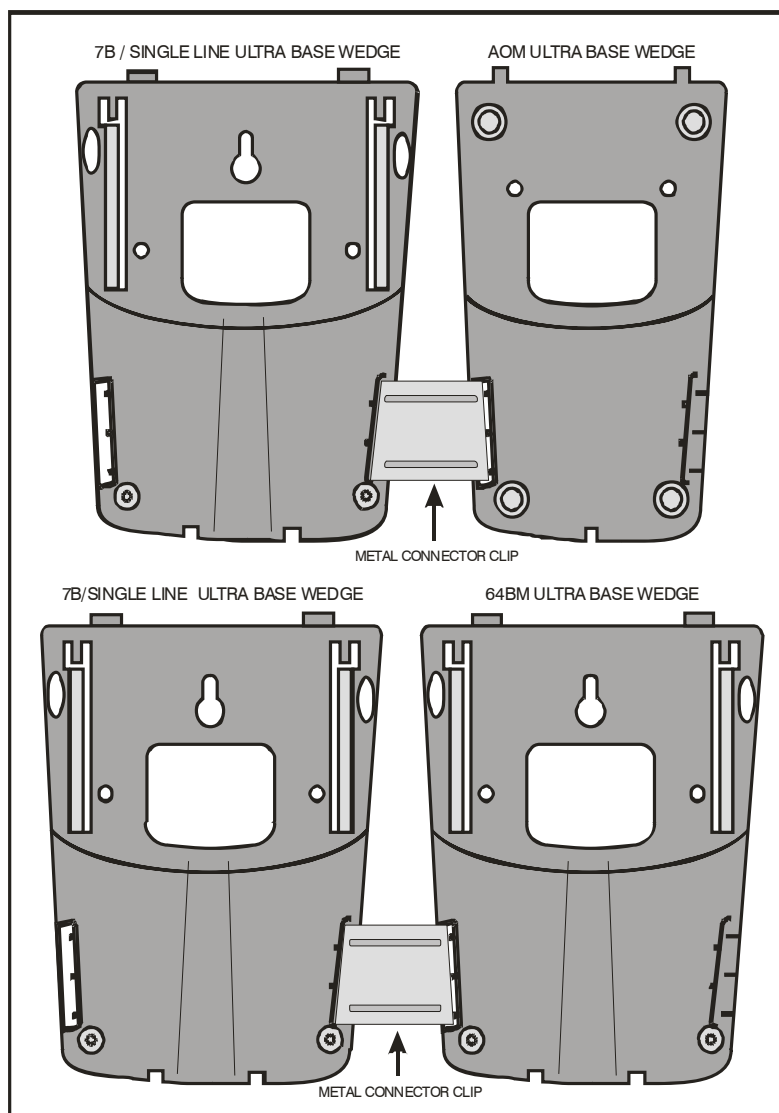

Figure 7.25 Attaching 7B/Single Line to AOM and 7B/Single Line to 64 Button Module

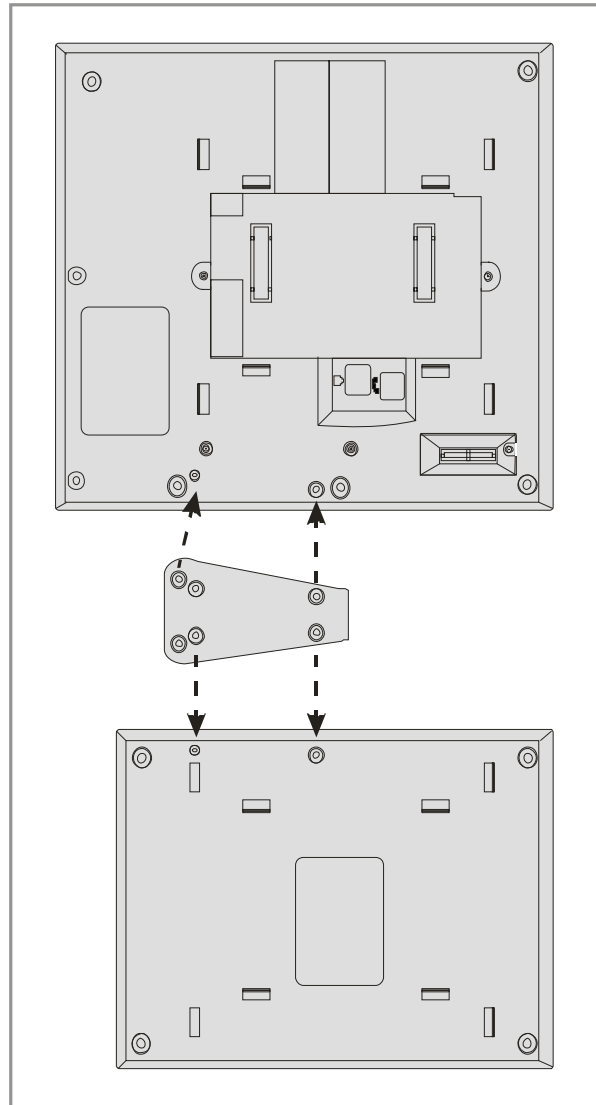

Figure 7.26 Attaching the iDCS 64 Button Module to an iDCS Keypad

ATTACHING iDCS 14 BUTTON MODULES TO AN iDCS KEYPAD

To add an iDCS 14 Button Key Strip to your iDCS keypad, follow these steps ([see Figure 7.26](#)).

- 1) Place the keypad face down on a flat surface.
- 2) Remove the base pedestal by placing your thumbs over the attachment clips and press outward while simultaneously pressing down on the keypad body with your fingertips.
- 3) Remove the ribbon cable knockout from the bottom of the keypad.
- 4) Clip the 14 button strip to the side of the keypad.
- 5) Plug one end of the ribbon cable into the keypad and the other end into the 14 button strip.
- 6) Place the support bracket over the ribbon cable and secure with the six screws provided.
- 7) Reattach the base pedestal.

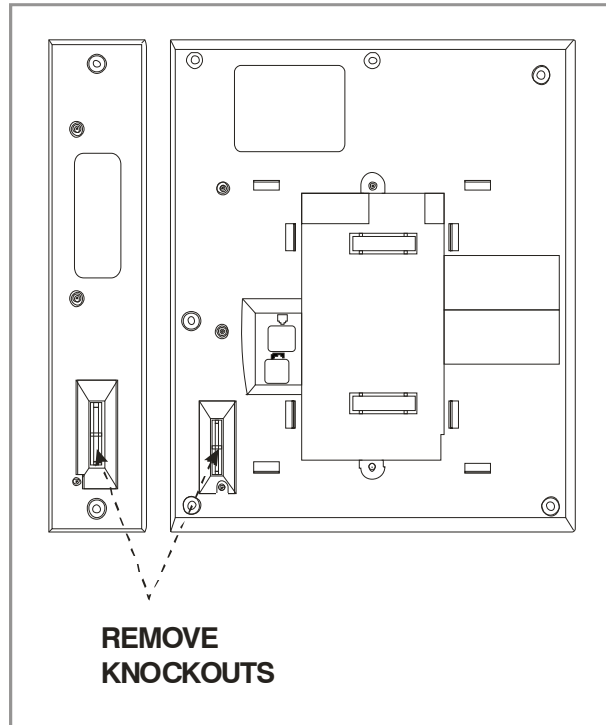

Figure 7.27 Attaching iDCS 14 Button AOM to an iDCS Keyset

ATTACHING DS 64 BUTTON MODULES TO a DS 5021D or a DS 5014D KEYSET

First attach the bracket to the keyset with two of the screws provided. Then attach the 64 button add-on module to the bracket with the remaining two screws. ([see Figure 7.28](#)).

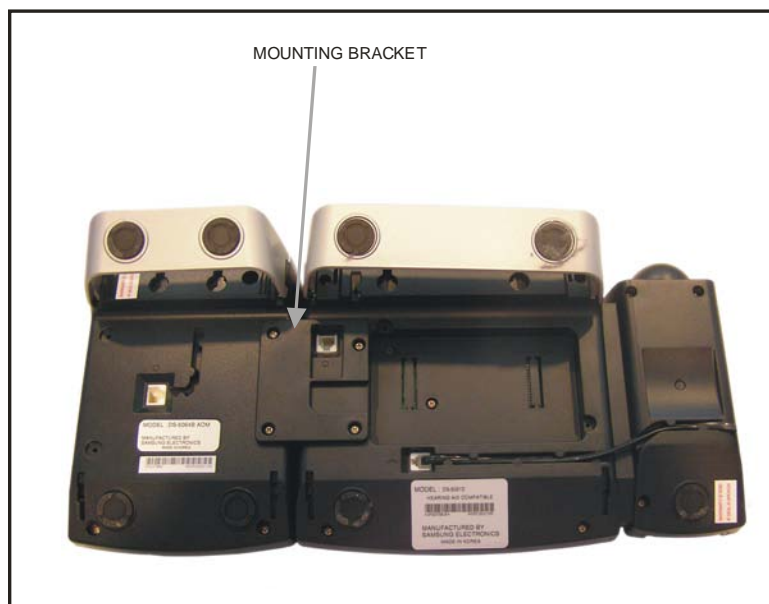

Figure 7.28 Attaching DS 64 Button Modules to a DS 5021D or a DS 5014D Keyset

SMT-i5264 ADD ON MODULE

The SMT-i5264 module can be used beside any ITP 5100 keysets, SMT-i Series, and TDM phones . The cosmetic design matches the SMT-I 5000 Series phones. The SMT-i5264 Add On Module only attaches to SMT-i5200 Series.

To attach the SMT-i5264 AOM to any SMT-I 5000 Series phones follow the steps below:

- 1) Remove the SMT-i5264 AOM stand and the cradle of the phone by pressing the [Push] mark on the top of the cradle to push it out.
- 2) Attach the bracket to the keyset with two of the screws provided.
- 3) Attach the SMT-i5264 AOM module to the bracket with the remaining two screws.
- 4) To connect to the phone, connect the UTP cable between the port and the LAN port of the IP phone. [\(See Figure 7.29\).](#)
- 5) To connect to the switch, connect the UTP cable between the LAN port and a port of the switch.
- 6) Add the stands back to the phone and AOM unit.

NOTE: SMT-i5264 AOM requires either PoE or a Power Adaptor (sold separately).

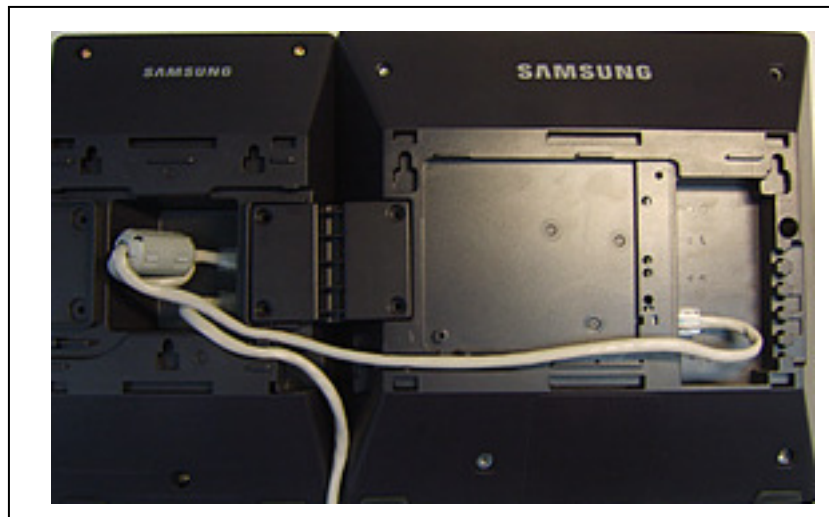

Figure 7.29 Attaching SMT-i5264 AOM to phone

If PoE is used, PoE connection should be connected to the LAN port of the SMT-i5264 (AOM) first then transfer over to the phone. As shown in Figure 7.29 the SMT-i5264 (AOM) can transfer the power from the LAN port to the phone port, but the phone can't transfer power to the AOM.

SETTING-UP SMT-i5264 AOM

SMT-i5264 AOM will register to the OfficeServ system as an IP phone device. It needs the IP phone ID and password during the registration. The SMT-i5264 will receive an IP phone extension. It can be paired to any IP phone or digital phone as the add-on module. MMC 209 is used to pair the AOM extension to a master phone.



Figure 7.30 Setting-Up SMT-i5264 AOM

- Prepare AOM to the set up mode
 - Press and hold 2nd key from the 1st column (left most columns) to enter the set up mode.
 - Press the 3rd key from the 4th column (right most columns) after this key is flashing.
 - (Press the 2rd key from the 4th column (right most columns) after this key is flashing will default the AOM to the factory settings.)
- Two methods to set up the AOM
 - Use SMT-i5243 phone to set up the AOM.
 - Enter SMT-i5243 phone to the engineering mode
 - Menu -> phone -> phone information -> *153#
 - Select Network -> AOM to enter into the set up mode
 - Enter the following data
 - If IP setting is DHCP skip this step
 - IP address: (assign an AOM IP address)
 - Gateway: (from MMC 830)
 - Subnet Mask: (from MMC 830)

- Server IP Address: (OfficeServ IP address from MMC 830)
- (use navigation key to move to the following fields)
- Server ID: (ITP ID from MMC 840)
- Server Password: (ITP password from MMC 840)
- Server Port: **6000 (press * key twice to switch input mode to numeric mode)**
- Use Web UI
 - Type IP address with port 8080 in the address bar of IE browser. Default AOM IP address is 10.0.0.3.
 - Ex.
 - <http://10.0.0.3:8080>
 - ID: admin
 - Password: samsung
 - Fill in the required data. Must enter the following information.
 - Server IP address is the OfficeServ MP IP address
 - Ex. 192.168.1.10
 - Enter an ITP ID and password
 - Ex:
 - id: 3210
 - pw: 1234
 - default port is **6000**
 - Press [Save] then [ReStart]
- Use **MMC 209** to pair AOM to any IP/TDM phone.
- Use MMC 722 to assign buttons.

		Server IP Address	105.52.21.37	Connected	
SYSTEM INFORMATION	Multi Server	ID / Password	ID : 6901	Password : ****	PORT : 6000
		2nd Server IP Address	10.0.0.2		
		ID / Password	ID :	Password :	PORT : [FFFFFFF]
		3rd Server IP Address	10.0.0.2		
		ID / Password	ID :	Password :	PORT : [FFFFFFF]
NETWORK		MAC Address	00-16-32-cd-44-60		
		Connection Mode	<input type="radio"/> Static IP <input checked="" type="radio"/> DHCP		
		IP Address	105.52.21.156		
		Subnet Mask	255.255.255.0		
		Default Gateway	105.52.21.1		
VLAN	AOM	Use	Not Us		
		ID / Priority	ID [2 ~ 4094] : 2	Priority : 7	
PHONE		Use	Not Us		
		ID / Priority	ID [2 ~ 4094] : 2	Priority : 4	
802.1x		Use	Not Us		
UPGRADE		ID / Password	ID : 0	Password :	
		S/W Version	V01.10(0812010900)		
		Server IP	105.52.21.194		

Figure 7.31 IP AOM Network Configuration

7.1.11 Connecting the SMT-A52GE Gigabit Adaptor

The Gigabit Adaptor processes the Gigabit data for a Gigabit LAN connection on the PC connected to the SMT-i5200 series IP phone.

COMPONENTS

The SMT-A52GE comes with the following components:



Gigabit Adaptor



2 Fixing Screws

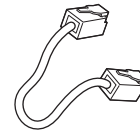

LAN Cable

CONFIGURATION AND FUNCTIONS

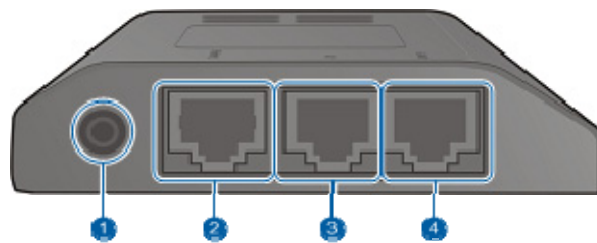

Port	Function
① Power (DC 5 V)	DC power adaptor connection port
② IP Phone PSE	<ul style="list-style-type: none"> A port connected to the IP phone's LAN port via the LAN cable. This is shipped together with the Gigabit Adaptor (10/100BASE-TX) If PoE (Power over Ethernet) is provided via the G-LAN PD port, it supplies PoE to the IP phone.
③ G-PC	<ul style="list-style-type: none"> LAN cable port connected to the PC (10/100/1000BASE-T)
④ G-LAN PD	<ul style="list-style-type: none"> LAN cable port connected to the network (10/100/1000BASE-T) If PoE is supplied via the LAN, a power supply is not required for the IP phone or adaptor.

NOTE: DC power adaptor is not included.

HOW TO CONNECT TO A PHONE

1. Separate the cradle at the back of the phone.

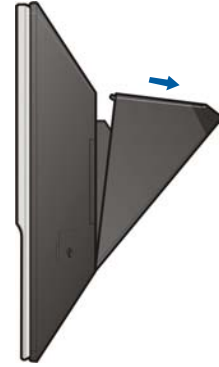

2. Mount the Gigabit Adaptor onto the back of the body.

NOTE: The back of the Gigabit Adaptor is sharp, so take care to avoid injury. When you connect the Gigabit Adaptor to the IP phone which is currently in use, disconnect the PC cable connected to the IP phone, and connect it to the G-PC port of the Gigabit Adaptor. This will leave the PC connection port, usually used for the IP phone, vacant.

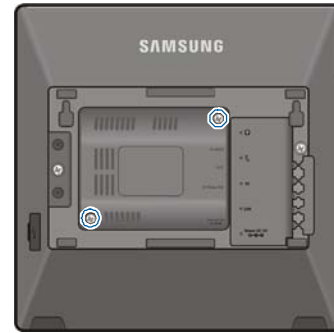

3. Connect the cable.

When PoE is supplied via the LAN:

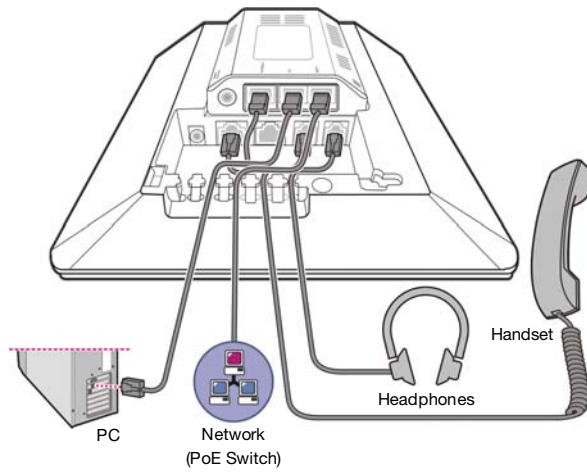

When PoE is not supplied via the LAN:

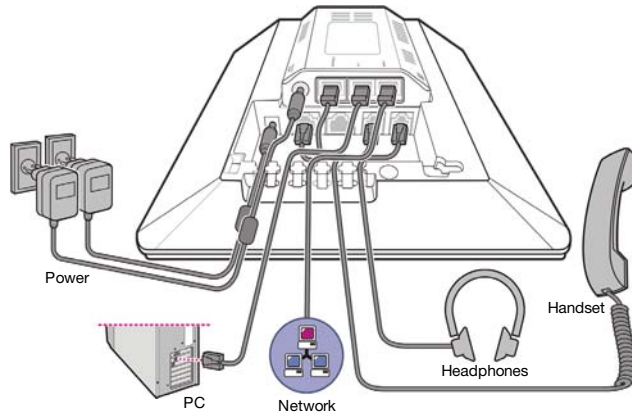

4. Attach the cradle to the back of the phone.

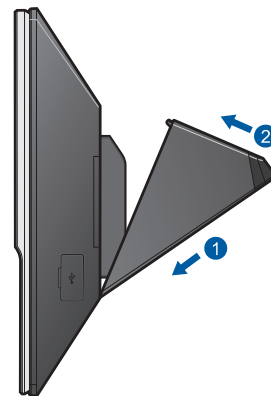

7.2 CONNECTING ADDITIONAL EQUIPMENT

This section describes how to connect optional equipment, such as Music on Hold (MOH)/Background Music (BGM) sources, external page devices, common bells, and PCs for PCMMC/IS Tool/SMDR/CTI, to the OfficeServ 7200 system.

The following table lists the default MISC Numbering Plan defined in MMC 724.

MISC FUNCTION # IN MMC 724	DEFAULT DN	HARDWARE ITEM
01	372	External MOH Source Input
02	373	External MOH Source Input
03	361	Page Tip and Ring
04	3961	Loud Bell Output
05	3951	Common Bell Delay
06	362	Dry Contact Relay
07	363	Dry Contact Relay
08	371	Internal Chimes
09 (MP20 ONLY)	3999	Modem

7.2.1 Connecting MOH/BGM Equipment

The OfficeServ 7200 system offers Music on Hold. The system provides internal tone/music and external music sources per C.O. or extension lines as the music source.

Two external music sources are offered. Connect the music sources to the MISC1 port of the MCP/MP20 board. The MIS optional daughterboard should be installed on the MCP/MP20 board.



NOTE

IMPORTANT NOTICE: In accordance with US copyright law, a license may be required from the American Society of Composers, Authors and Publishers (ASCAP) or another similar organization if copyrighted music is transmitted through the Music on Hold feature. Samsung Telecommunications America hereby disclaims any liability arising out of failure to obtain such a license.

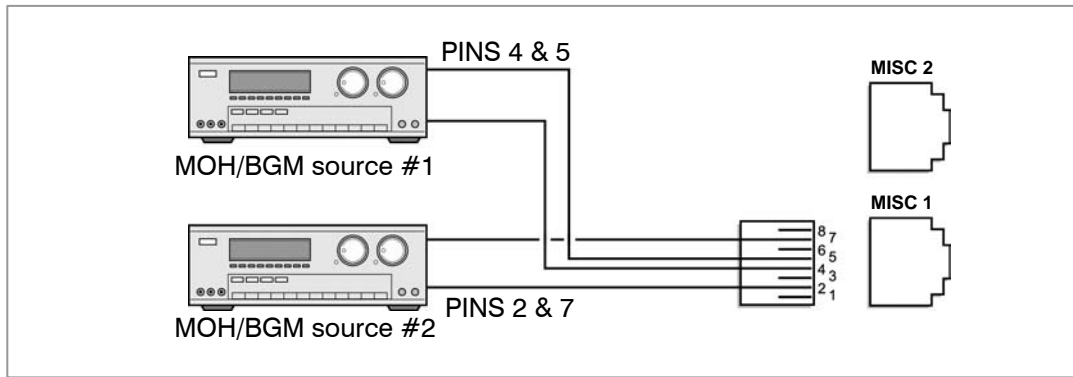

Figure 7.32 Connecting MOH/BGM Sources

- MISC 1 and MISC 2 ports are located on the front panel of the MCP/MP20.



MMC

Select music sources for C.O. lines in MMC 408 and music sources for extensions in MMC 308. For detailed instructions on the MMC programs, refer to [OfficeServ 7200 Programming Manual](#).

The following ports are assigned to the external MOH inputs on the MIS daughtercard:

HARDWARE ITEM	MISC FUNCTION # in MMC 724	DEFAULT DN (Ports)
MOH/BGM Ext. Source #1	01	3762
MOH/BGM Ext. Source #2	02	3763

7.2.2 Connecting External/Additional Page Equipment

Instead of an internal speaker, external broadcasting equipment, such as amps or speakers, and additional equipment that can broadcast page (ring) signals outside a building can be connected to the OfficeServ 7200 system.

Connect external/additional paging equipment to the MISC1 and MISC2 ports of the MCP/MP20 board. The MIS optional daughterboard should be installed on the MCP/MP20 board. The power of the external/additional paging equipment should be connected separately.

The MIS daughterboard provides a voice pair and a two dry contact pairs to be used with customer-provided paging equipment. Connect the customer-provided paging equipment to the page output pins of a MIS daughterboard ([see Figure 7.33](#)).

The Page Zone Relay ports assigned to each dry contact pair are listed in the following table. Assign the DN number to the selected page zone using Default DN (Ports).

HARDWARE ITEM	MISC FUNCTION # in MMC 724	DEFAULT DN (Ports)
Page Tip & Ring	03	3751
Contact Pair #2	06	3752
Contact Pair #3	07	3753

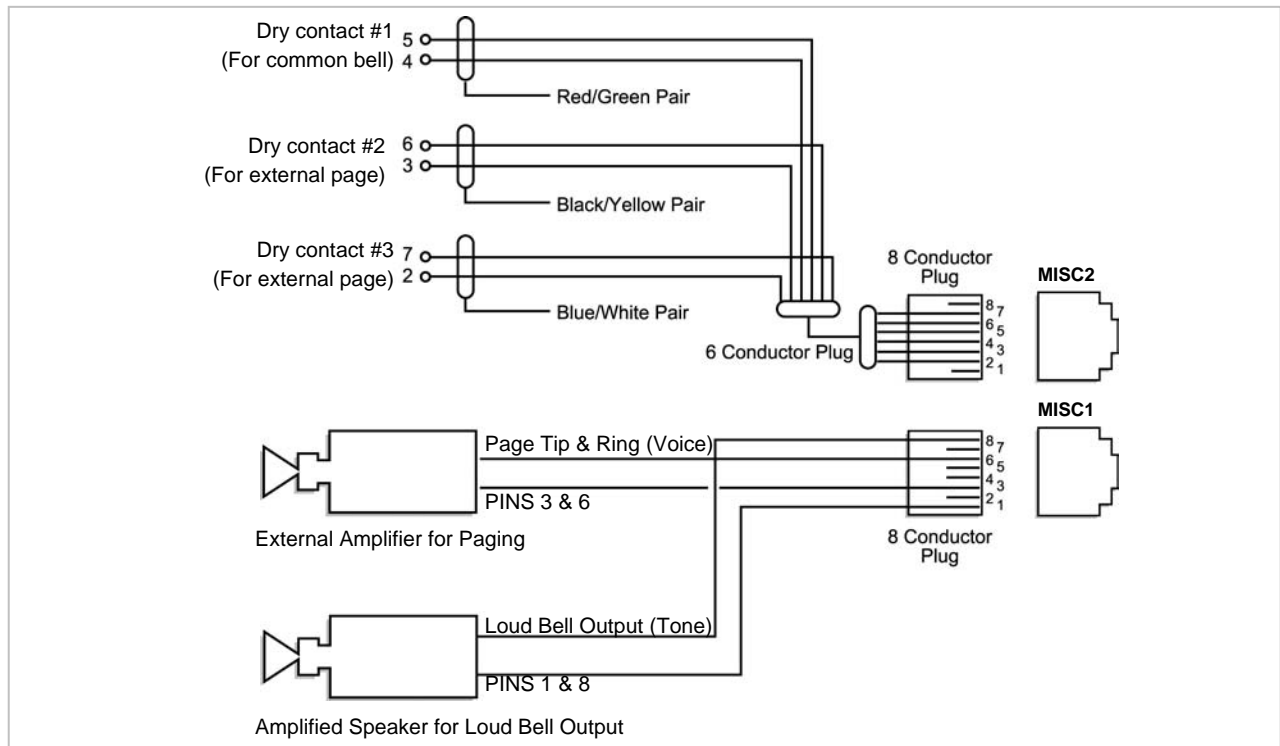

Figure 7.33 Connecting External/Additional Page Equipment

- MISC 1 and MISC 2 ports are located on the front panel of the MCP/MP20.



Dry Contact

Dry Contact is a switch that can connect or cut the power or line to external equipment.

7.2.3 Loud Bell Interface

When a station requires loud ringing, assign or pair that station to an audible ring tone output on the MIS daughterboard using MMC 205.

MISC FUNCTION # in MMC 724	DEFAULT DN
04	395

Next connect the output from the MIS daughter card to a customer provided paging system or other suitable customer provided speaker ([see Figure 7.34](#)).

7.2.4 Connecting Common Bell

A customer-provided loud ringing device can be controlled using a dry contact pair on the MIS daughter board.

Common bell connections should be wired to the MISC1 and MISC2 ports of the MCP/MP20 board. An MIS optional daughter board should be installed on the MCP/MP20 board.

By using MMC 204 programming allows for interrupted or continuous operation of the contacts. The interrupted selection follows the CO ring cadence, 1 sec ON/3 sec OFF.

MISC FUNCTION # in MMC 724	DEFAULT DN
05	3991

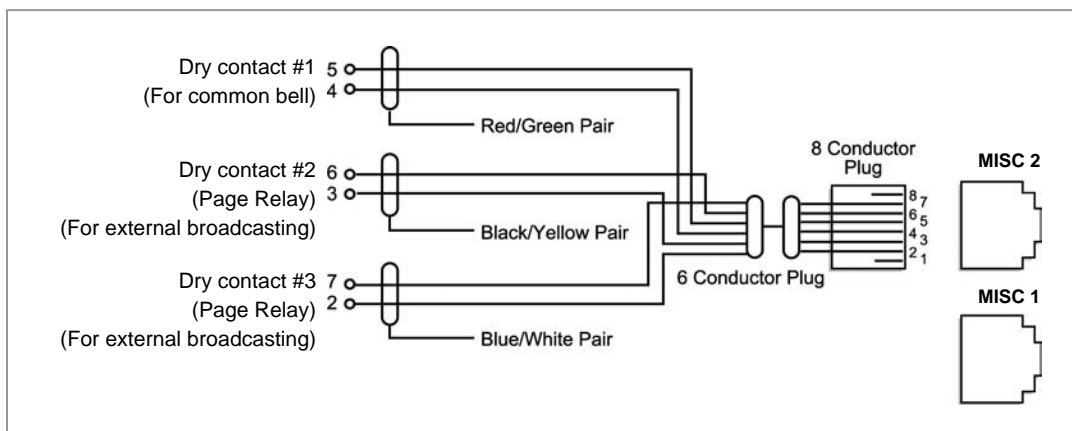

Figure 7.34 Connecting Common Bell

- MISC 1 and MISC 2 ports are located on the front panel of the MCP/MP20.

WARNING: Do not attempt to connect commercial AC power to these contacts.

- 1) After connecting a common bell, you must assign it in MMC 601 to a group as a ring destination by using the code for common bell.
- 2) After wiring to the contact pair, set contacts for continuous or steady operation.
- 3) Next, program hunt group to include the common bell.
- 4) Assign the trunk to ring the hunt group containing the common bell. Common bell control can be used with station hunt groups, individual stations and universal answer.

7.2.5 Ring Over Page

When a customer-provided paging system is installed, incoming calls can be assigned to ring over page. Program the C.O. line or C.O. lines to ring a hunt group. Using MMC 601 assign the DN number of the Page Output (voice) for the MIS board being used as a member of the group or as the NEXT PORT for the overflow destination. Other stations may be assigned to the same group to provide ringing to phones and the paging system at the same time.

MIS FUNCTION # in MMC 724	DEFAULT DN
03	3751

7.2.6 Connecting OfficeServ Manager

OfficeServ Manager (OSM) is a windows based computer application that provides maintenance and management functions for the OfficeServ 7200.

The minimum requirements for a PC running OfficeServ Manager (OSM) are as follows:

Table 7.3 OfficeServ Manager Specification

Category	Specification
Platform	IBM PC
CPU	Pentium III or higher
OS	Windows 2000 or higher
Main memory	64Mb or higher
Hard disk	1Gb or higher

Beginning with system software version 4.14K technician must use OfficeServ Installation Tool.

CONNECTING OFFICESERV MANAGER (OSM) TO LAN PORT

The OSM application can only communicate to the OfficeServ 7200 system via the LAN connection. The OSM or Installation Tool (OIT) PC can connect to the MCP/MP20 via LAN connection using a customer provided LAN switch or using the PLIM/PLIM2 module as shown in Figure 7.32.

- Set up the MCP/MP20 LAN parameters in MMC 830.
- If an MCP/MP20 is behind a firewall and OSM or Installation Tool (OIT) is outside the firewall, ports 5000, 5003, and 5200 (TCP) must be open to the private IP address of the MCP/MP20.

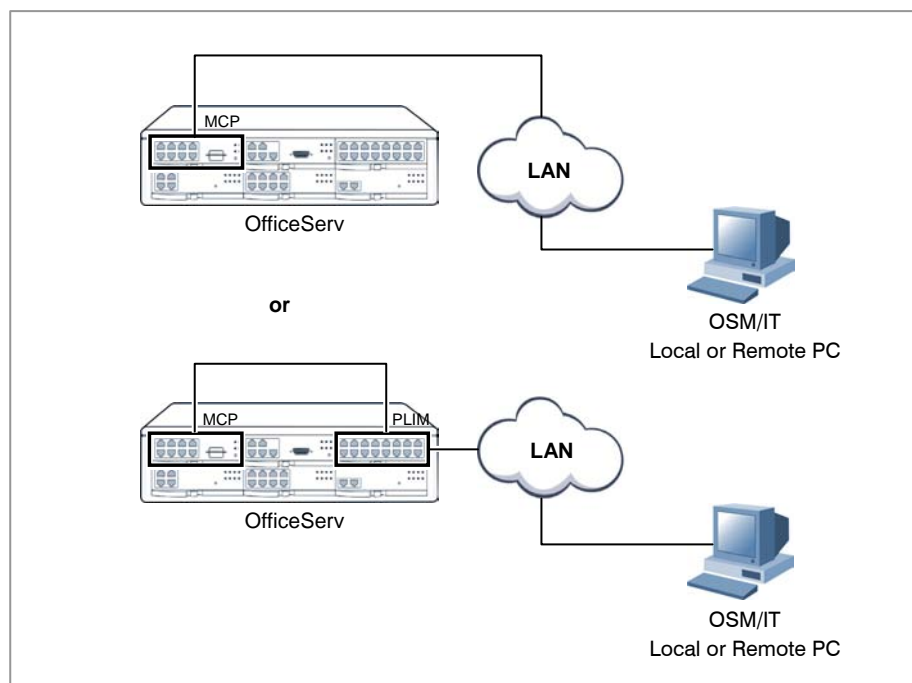



Figure 7.35 OSM/OSIT Connection to PLIM/PLIM2 Board via LAN

Detail procedures for each of the steps above are as follows:

SETTING NETWORK PARAMETERS THROUGH MMC 830

Set the network parameters of the system. Contact the network manager when setting values for the network parameters.

- 1) Set the IP address of the system.
- 2) Set the subnet.
- 3) Set the gateway address.
- 4) Reset the board.

 **Board Reset**
New settings are applied only after the board is reset. The system may malfunction if the board is not properly initialized.

SETTING REMOTE OSM PARAMETERS

- 1) Execute OSM.
- 2) Click [Link] → [CommSetup] menu on the OfficeServ Manager main screen.

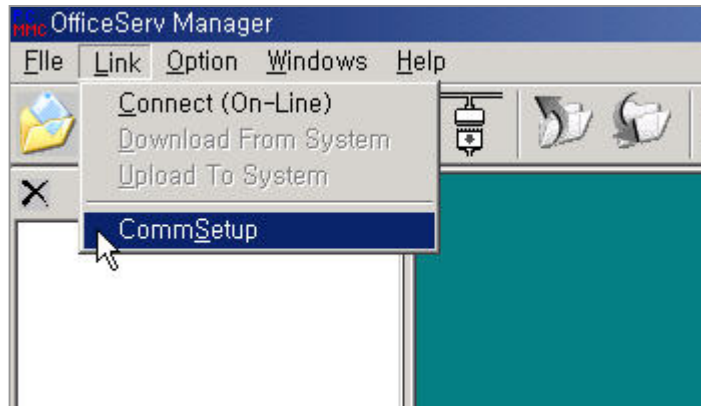

Figure 7.36 OSM Screen

- 3) Enter the system name into the [Address] field of the <Communications Setup> window.
- 4) Enter the IP address of the system into the [Number] field.

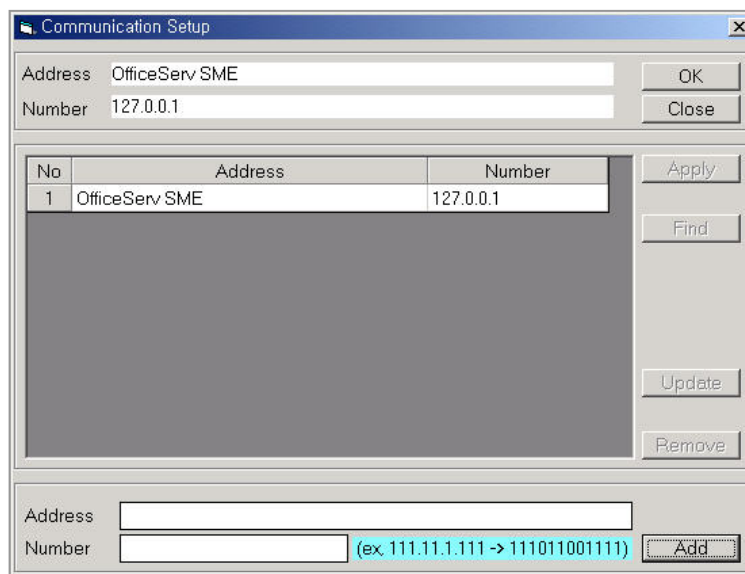

Figure 7.37 Setting OSM Parameters

7.2.7 OfficeServ Installation Tool

The OfficeServ Installation Tool (OIT) is a windows based application designed to manage the OfficeServ 7000 Series systems over a LAN, WAN, or modem connection either remotely or on-site. The OfficeServ Installation Tool replaces OSM beginning with system version 4.14K or higher.

This single application solution makes it easy and convenient for system administrators, because the OIT's user-friendly GUI can be utilized to change system, station, and trunk parameters, save or restore system databases, and perform file management functions (write files to the Smart Media or MMC Plus Cards) on all of the OfficeServ 7000 Series systems.

With OIT it is now possible to compare OfficeServ 7000 Series databases, which makes it simple for system administrators to verify and pinpoint modifications in the system programming from one database to another. The OIT can also be configured with convenient bookmarks, which offers simple one click access to the most commonly used parameters.

Although the programming structure of the OIT has moved away from a purely MMC design it is still possible to correlate the OIT Menu numbers with specific MMC numbers. By using the "by MMC" search field and "MMC Mouse Over" feature it is easy to determine which IT Menu belongs to which MMC number.

MINIMUM PC REQUIREMENTS

Listed below are the minimum PC requirements for the OIT to function properly.

Table 7.4 Minimum PC Requirements for Installation Tool

H/W	Requirement	
PC	CPU	Pentium III or faster
	Main Memory	Minimum of 512 MB
	HDD Drive	At least 30 MB
	Operating Systems	Microsoft Windows 98
		Microsoft Windows 2000 (all editions)
Microsoft Windows XP (all editions)		
Microsoft Windows Vista (all editions)		
Modem	1,200~115,200 baudrate when using a modem connection to the OfficeServ 7000 system	
LAN (Ethernet)	10/100 Base-T when using a LAN/Internet connection to the OfficeServ 7000 system	

MINIMUM OS 7000 SERIES SOFTWARE VERSION REQUIREMENTS

Listed below are the minimum phone system software requirements for the OfficeServ Installation Tool to function properly.

Table 7.5 Minimum Software Version Requirements for Installation Tool

H/W	Minimum Software Version Requirement
7100 MP10	Version 4.04a
7100 MP10a	Version 4.24
7200 MCP	Version 4.14k
7200 MP20	Version 4.23b
7400 MP40	Version 4.14k



When installing or uninstalling the OIT

Samsung recommends backing up all 7000 Series System databases to a safe location before proceeding with an installation/uninstallation of the OfficeServ Installation Tool.

For information on how to install the application, please refer to the Installation Tool User Manual.

LINK CONTROL

Site List: In order to connect to an OfficeServ 7000 Series system the site information must be entered into the Link Control. The **[Link Control]** sub-menu is used to configure the communication environment between the IT and the OfficeServ 7000 Series key phone system. Click on the **[System]** → **[Link Control]** sub-menu and the following window will be displayed:

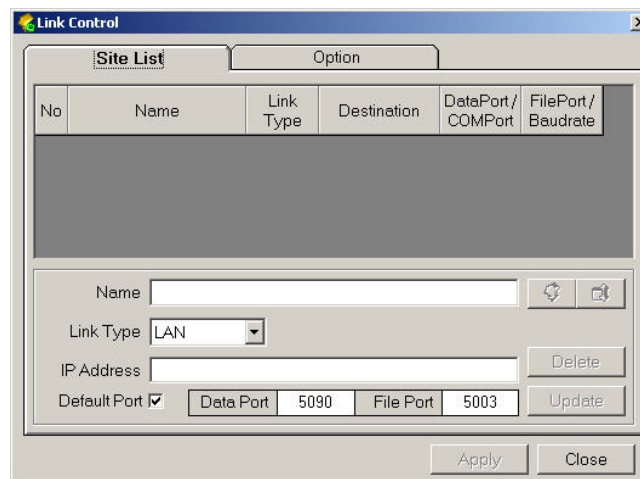

Figure 7.38 Link Control: Site List Tab

Refer to the following table for a description of each Link Control parameter.

Table 7.6 Link Control Parameters

Field	Details	
Name	Used to enter the name of the customer site.	
Link Type	Used to select the connection type for the PC doing OIT administration.	<ol style="list-style-type: none"> 1. LAN – Local Area Network 2. MODEM (Not supported on the OS 7200.)
IP Address	If the Link type is set to LAN, this parameter can be modified. Enter the IP Address assigned to the MP10/MP10a/MCP/MP20/MP40.	
Telephone	If the Link type is set to Modem, this parameter can be modified. Enter the phone number associated to the OfficeServ 7000 Series system modem (Not supported on the OS 7200).	
Data Port	If the Link type is set to LAN, this parameter can be modified. Enter the port number that the OfficeServ Installation Tool will use to connect to the MP10/MP10a/MCP/MP20/MP40 over the LAN connection (only use in specific circumstances such as NAT).	
File Port	If the Link type is set to LAN, this parameter can be modified. Enter the port number that the OfficeServ Installation Tool will use for file transfers to the MP10/MP10a/MCP/MP20/MP40 over the LAN connection (only use in specific circumstances such as NAT).	
COM Port	If the Link type is set to Modem, this parameter can be modified. Select the modem's COM port.	
Baud rate	If the Link type is set to Modem, this parameter can be modified. Select the appropriate modem speed.	
[Delete] Button	Used to delete the selected site information.	
[Update] Button	Used to store the selected site information.	
[Apply] Button	Used to select the site which the OIT will connect to when the [Connect] button is clicked.	
[Close] Button	Used to close the Link Control window.	

THE TWO [LINK TYPE] SETTINGS

From the <Link Control> window's [**Link Type**] field, select one of the two following connection methods:

- **Modem:** Use the PC's modem to connect to the key phone system. (COM 1~10: We suggest using an external modem for this purpose.)
- **LAN:** Use the PC's LAN to connect to the key phone system. (You may use a cross-over LAN cable to connect directly to the key phone system's LAN port. Alternatively, you may use a straight LAN cable to connect to the network.)

If the Link Type for a particular site is set to LAN, an IP address must be obtained from the System Administrator. This IP address may be programmed into the system using MMC 830. Once programmed, the same IP address must be entered on the IP Address line in Link Control. Enter the IP Address of the MP10/MP10a/MCP/MP20/MP40 card and then click the [Update] button to save the change. If different ports need to be used, then uncheck the [Default Port] box and then enter the appropriate port information for the [Data Port] (MP10/MP10a/MCP/MP20/MP40 Connectivity) and the [File Port] (Upload Files to Storage Media.)

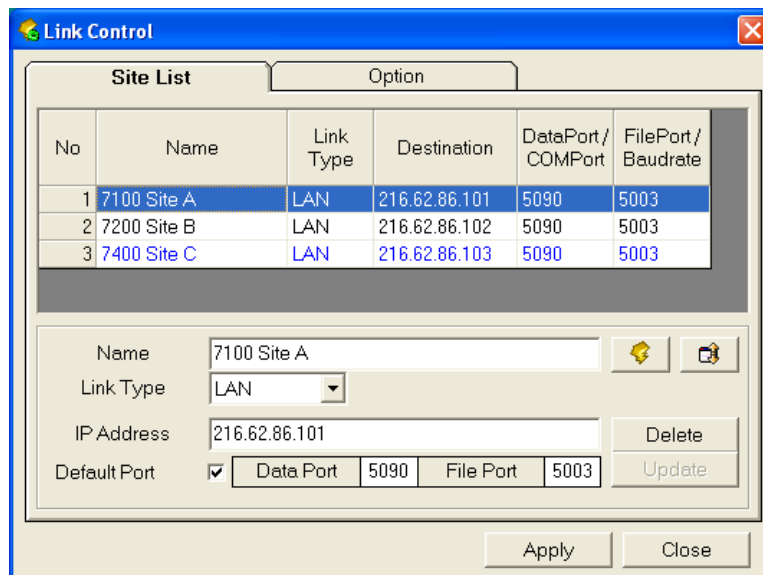



Figure 7.39 Site List Detailed Information



NOTE

Entering the system IP

The IP address field in the OIT refers to the OfficeServ 7000 Series system's IP address to which the OIT will connect. The information can be verified by logging into an OfficeServ 7000 Series system via KMMC, and then by viewing MMC 830 'ETHERNET PAR'.

Once a site is defined and highlighted in the top section of the <Link Control> window (see [Figure 7.40](#)), simply click on the  icon to connect to the MP10/MP10a/MCP/MP20/MP40.

The  icon is used to upload OfficeServ application files to the storage media.

In order to change a particular parameter on a defined site, highlight the site (like in the picture above), modify the parameters on the bottom part of the window, and then click the **[Update]** button.

If the **[Link Type]** for a particular site is set to Modem, enter the COM port number, the baud rate, and the telephone number for the modem connected to the MP10/MP10a/MCP/MP20/MP40 and then click the [Update] button to save the change.

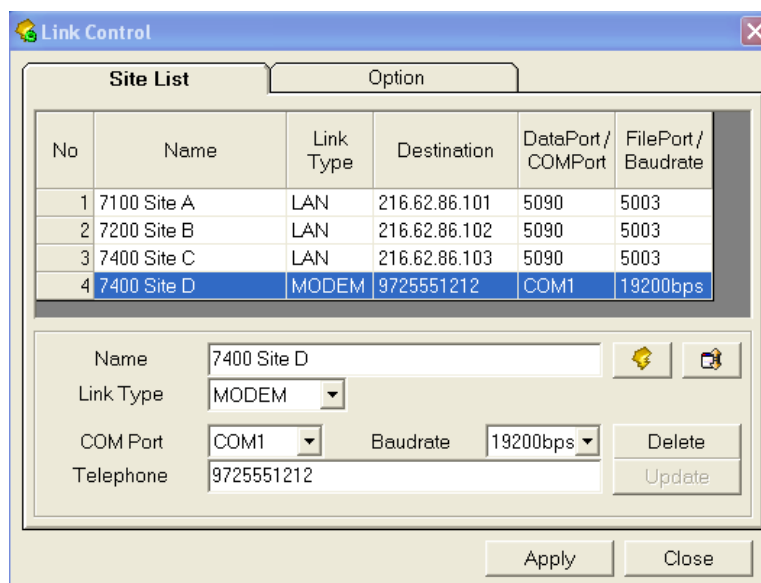

Figure 7.40 Site List: Link Type Modem

OPTION

The **[Option]** tab may be selected to set additional information regarding the modem connection (between the OIT and the key phone system.)

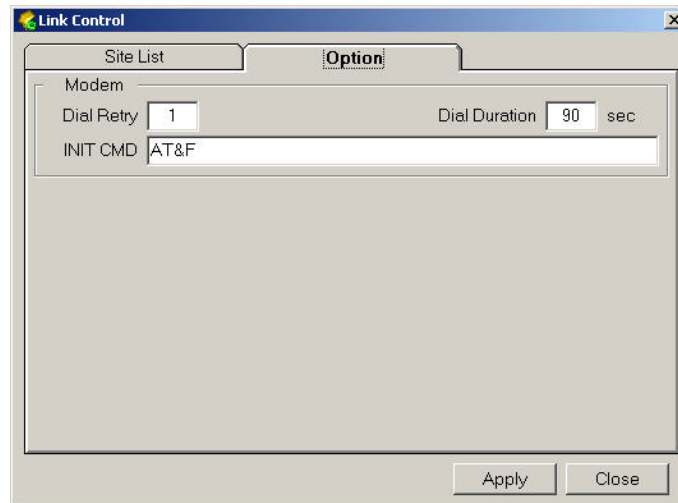



Figure 7.41 Link Control: Option Tab

Once a site is defined and displayed in the bottom section of the <Link Control> window, simply click on the  icon to connect to the MP10/MP10a/MCP/MP20/MP40.

The  icon is used to upload OfficeServ system files to the storage media.

Refer to the following table to configure the modem's options:

Table 7.7 Modem Configuration

Field	Details
Dial Retry	Used to set the number of attempts (dial counts) for the modem connection.
Dial Duration	Used to set the connection time (uptime) for the modem connection.
INIT CMD	Used to set the modem's initialization command.

7.2.8 Device Manager (DM) Tool

The OfficeServ Device Manager is a Windows™ application that allows programming of the OfficeServ™ 7000 Series phone systems from a PC over a data network or modem. The Device Manager allows access to OfficeServ™ Man Machine Code (MMC) programming through an intuitive programming interface without the need to memorize MMC numbers or keypad programming procedures.

In addition to system programming the Device Manager also provides the ability to manage files on the system media card allowing administrators to upgrade main system software without the need for a media card reader. The Device Manager also allows downloading, uploading, and comparison of system databases as well as offline editing of stored databases.

Device Manager is available in two styles:

1. Embedded: On some systems the Device Manager application is embedded on the phone system processor card. The system is then accessed using a web browser to connect to the embedded application. This can be done over either a private network or a public network. The benefit to this method is that you are always using the correct Device Manager version to correlate to the system you are configuring.
2. Client: Systems that do not support the embedded Device Manager application can be accessed using a client version of Device Manager that resides on the technician's PC.

The Device Manager application is used for the following:

- **Organize Site Connections**
Save connection properties for multiple phone systems for quick access with the Link Control.
- **Local and Remote Administration**
Connect via LAN, Internet, or modem to any OfficeServ™ 7000 Series system from anywhere.
- **Manage System Databases**
Download system databases to your PC for archiving or offline editing. Upload databases to the system to push large changes with minimal service downtime.
- **Manage Media Card Files**
View, add, or delete operating system files on the Media Card for your OfficeServ™ 7000 Series system to ease version upgrades for the processor and interface cards.

- **Compare Databases**
The Database Compare function helps you track changes between archives by detecting and displaying any differences between two saved databases.
- **Store Programming Favorites**
Bookmarks increase efficiency by allowing you to save a list of commonly used programming screens.
- **Search Menus**
The search feature greatly reduces headaches by allowing you to search for a programming option by MMC number, field name, or menu item name.

MINIMUM REQUIREMENTS

1. Embedded Application Web Browser Requirements

Table 7.8 DM Embedded Application Web Browser Requirements

Web Browser	Version
Internet Explorer	6.0, 7.0 or 8.0

2. Client Application Minimum PC Requirements

Table 7.9 Client Application PC Requirements

H/W	Requirement	
PC	CPU	Pentium Iv or faster
	Main Memory	512 MBytes or more
	HDD Drive	At least 1 GBytes of free space
	OS	Microsoft Windows XP or newer
Modem	1,200~115,200 baud rate	

SOFTWARE COMPATIBILITY

1. Embedded Application

Table 7.10 Embedded Application Software Compatibility

System	Software Version
OfficeServ 7400	4.52 and higher
OfficeServ 7200 (MP20)	4.52 and higher
OfficeServ 7200 (MCP)	Not Supported
OfficeServ 7200-S	4.52 and higher
OfficeServ 7030	4.53 and higher
OfficeServ 7100	4.53 and higher

2. Client Application: The client application can be used on OfficeServ 7000 series systems using software version 4.51 and lower.

LAUNCHING DEVICE MANAGER

Before you can successfully access an OfficeServ System using the embedded Device Manager via a web browser, there are a few things that need to be set or verified.

1. Enable the Downloads/File Download option in Internet Security Settings

This setting can be found under the **Tools/Internet** Options menu in Internet Explorer. Select the **Security** tab and then the **Custom Level** button.

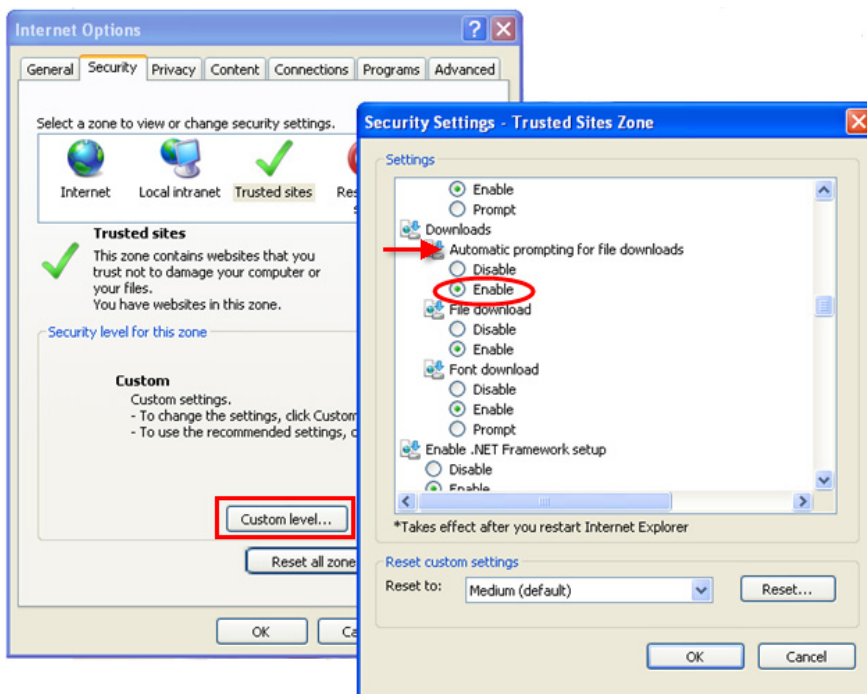

Figure 7.42 Security Settings to Enable Downloads

2. Enable Popups

Device Manager will be launched in a pop-up window, therefore the pop-up blocker must be turned off in the web browser.

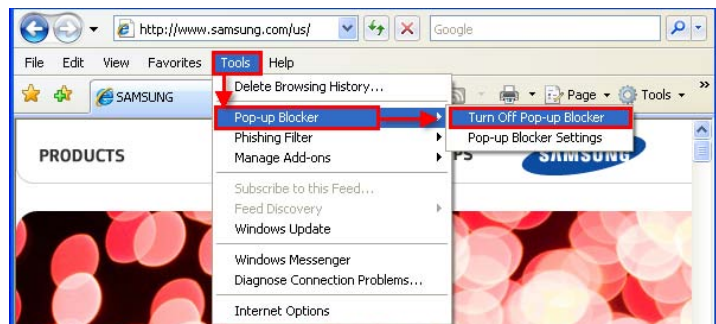

Figure 7.43 Enable Pop-Ups

3. Java Plug-In

Java Web Start Plugin should be installed to use OfficeServ DM. If it's not, you will be prompted to download it when you attempt to launch Device Manager.

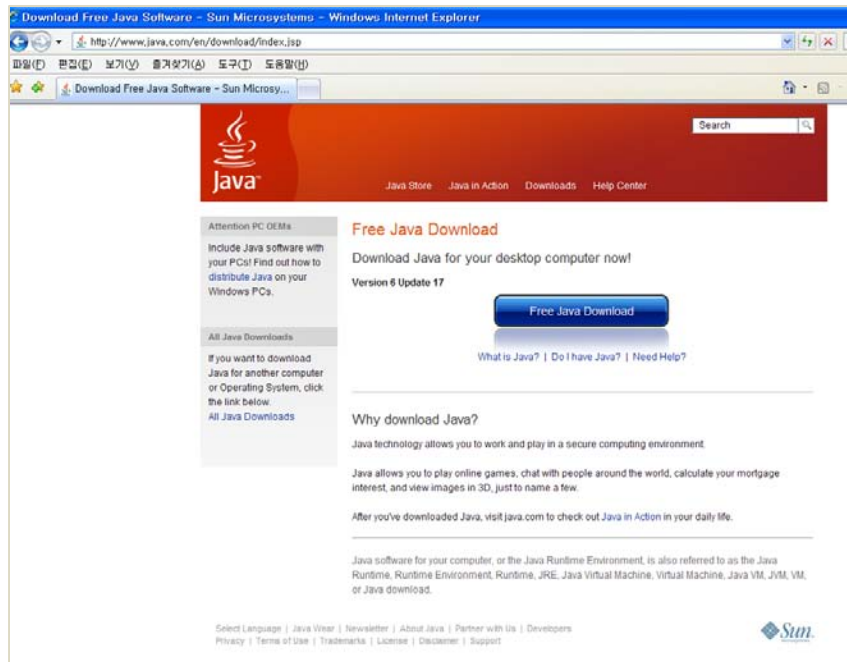



Figure 7.44 Java

 **NOTE** JRE 1.6 or higher should be installed to use OfficeServ DM. If an old version of JRE (i.e., lower than the version 1.6) is installed, please remove it and replace with a new version.

4. **Trusted Sites:** If you have difficulty connecting to a site, you may need to add it to your browser's trusted sites.

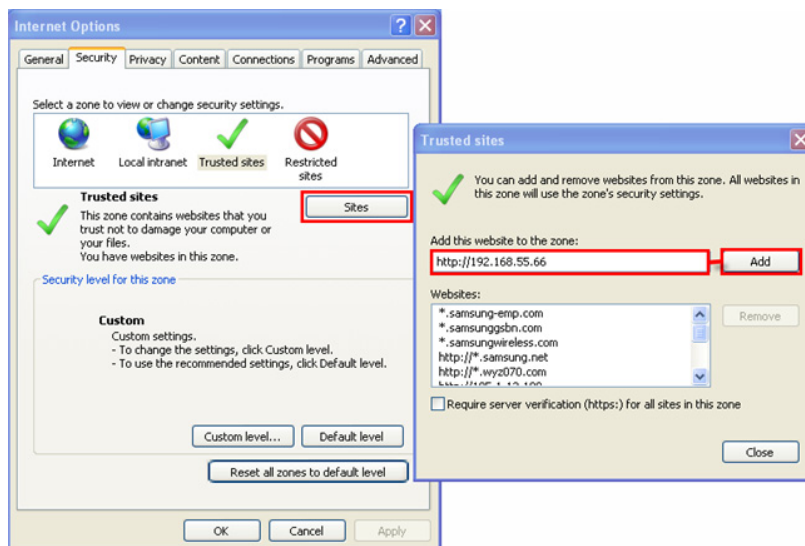

Figure 7.45 Trusted Sites

5. Ports

When using a public network to access an OfficeServ system with Device Manager, firewall ports 80 and 21 must be opened on the router.

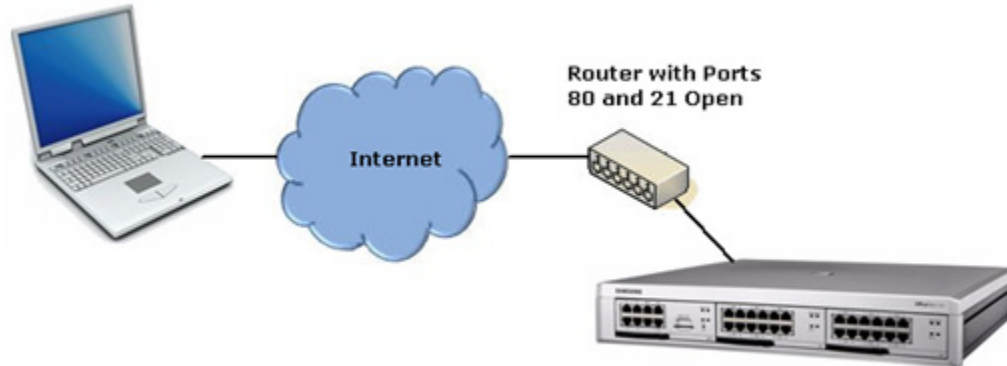

Figure 7.46 Firewall Ports

CONNECTING TO THE EMBEDDED DEVICE MANAGER

Device Manager is launched with a web browser. Depending on the environment, one of the following addresses should be used to access the embedded Device Manager.

Environment	Command	Example
Private Network	http://OfficeServ System IP Address/dm/	http://192.168.45.56/dm/
Public Network	http://OfficeServ System IP Address/dmp/	http://192.168.45.56/dmp/
MP20S Processor Card	https://OfficeServ System IP Address	https://192.168.45.56

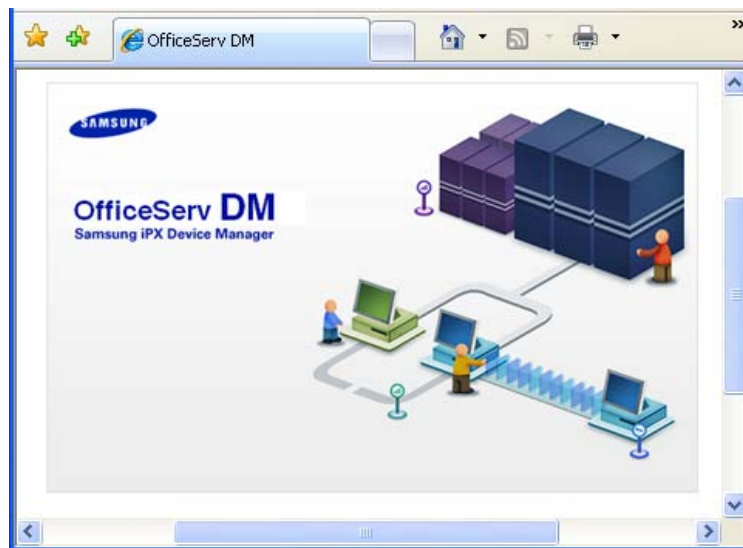

Figure 7.47 DM Splash Screen

You may see the following warning screen. Simply click on the Run option if you do.



Figure 7.48 Security Warning

Device Manager will open in a separate window. This may take up to 15 seconds to open. The default Login ID is **admin** and the default password is **samsung**.

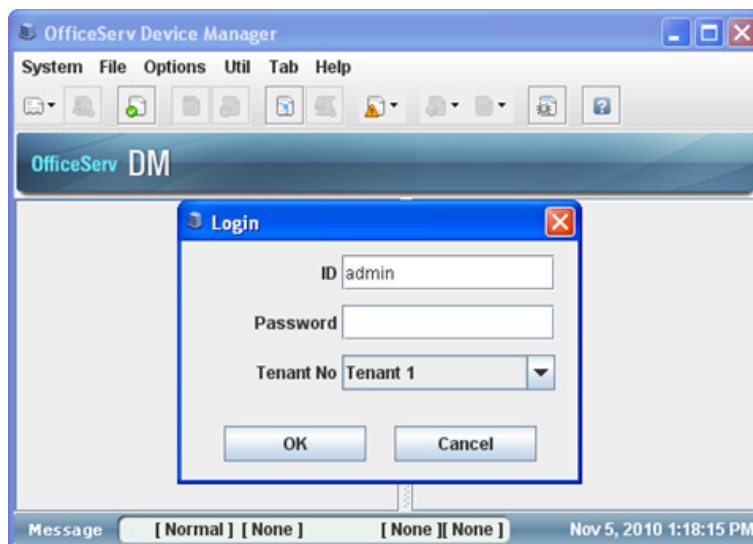

Figure 7.49 DM Login Page

LAUNCHING THE OFFICESERV DEVICE MANAGER CLIENT APPLICATION

Unzip the file obtained from the Samsung GSN website. The zip file will contain one file - OSDM.JAR file. This is the file used to launch Device Manager. For ease of use, we recommend placing this file on your desktop.

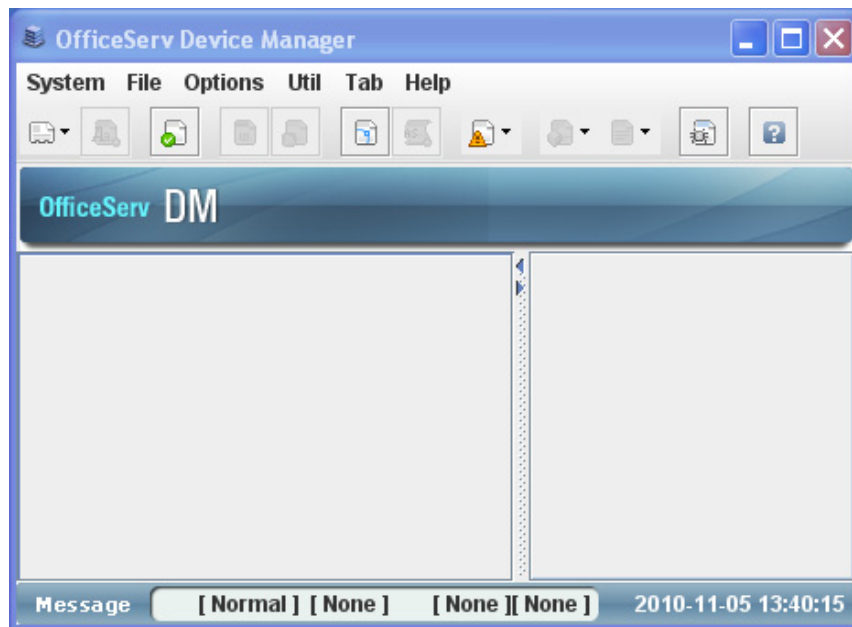

Figure 7.50 OS Device Manager Client Application Open Screen

LINK SETUP

The Link Setup window is a connection manager for your OfficeServ system connections. You must enter a site into the Site list before connecting to an OfficeServ System.

- Click on **[System]** => **[Link Control]**. The following screen is displayed.

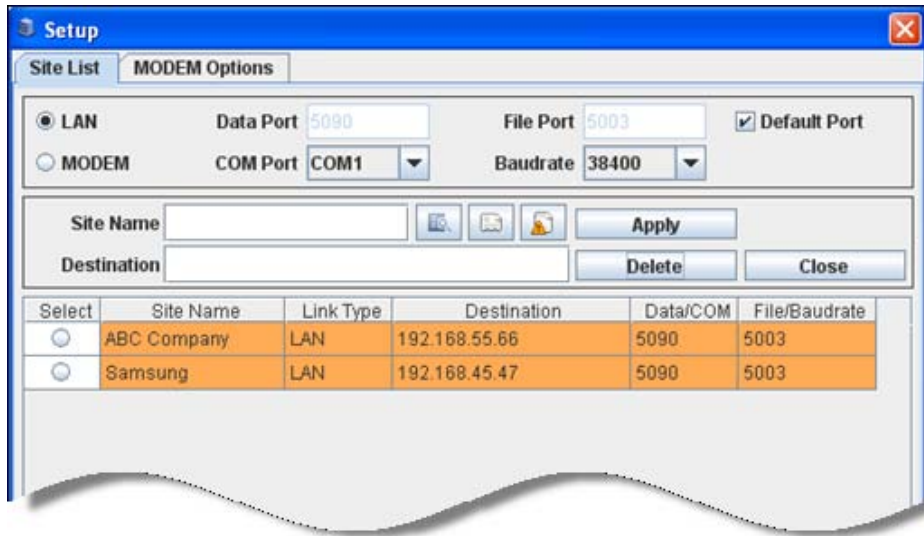

Figure 7.51 Link Setup

1. Site List

The Site List allows you to add, edit, or delete site information as well as view data for all your stored connections.

Clicking the radio button for a site will cause the connection detail for that site to populate in the upper portion of the window. To edit the data, make your changes and then click **[Apply]**.

To create a new LAN site connection you must enter a few pieces of information:

- **Site Name** sets the name for the connection, which is used mainly for your reference.
- **Link Type** (top of screen) should be set to LAN, which is the default.
- **IP Address** sets the IP address to connect to the system on.

Default Port sets the IP connection ports to use for this site. The default is 5090 for programming and 5003 for Media Card access. To set new values you must uncheck the Default Port checkbox.

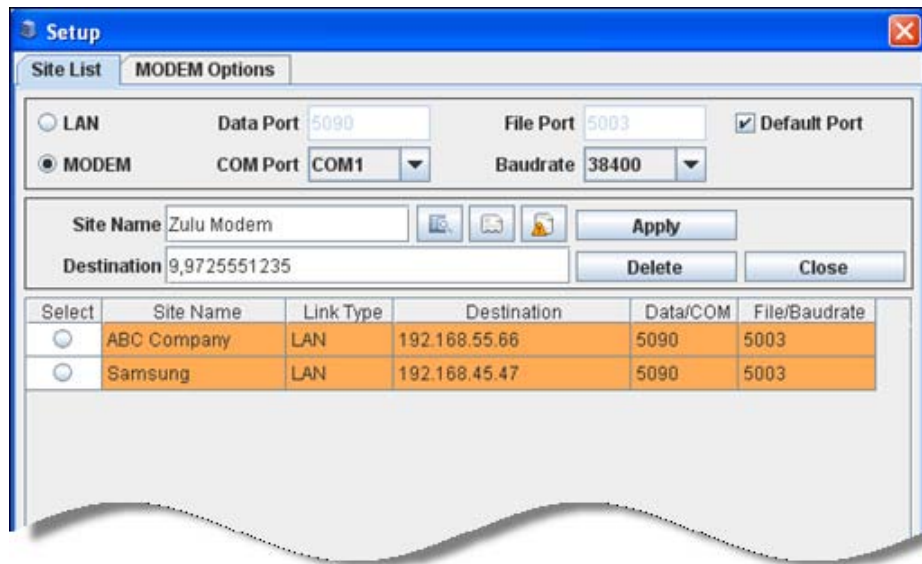

Figure 7.52 Site List

To create a new Modem site connection you must enter several pieces of information:

- **Site Name** sets the name for the connection, which is used mainly for your reference.
- **Link Type** (top of screen) should be set to MODEM.
- **COM Port** determines the port on your PC that the MODEM is connected to. This can be obtained in Windows XP by clicking [Start] → [Settings] → [Control Panel] → [Printers and Other Hardware] and double-clicking "Phone and Modem Options". Once loaded click the **Modems** tab and the COM port is listed under the column **Attached To**.
- **Baudrate** determines the connection speed. This setting defaults to 38400.
- **Destination** is the phone number to dial after accessing the MODEM to connect to the system.

2. Modem Options

The Modem Options tab allows you to set configuration parameters for MODEM connections. Once changes have been made you must click **[Apply]** to save them.

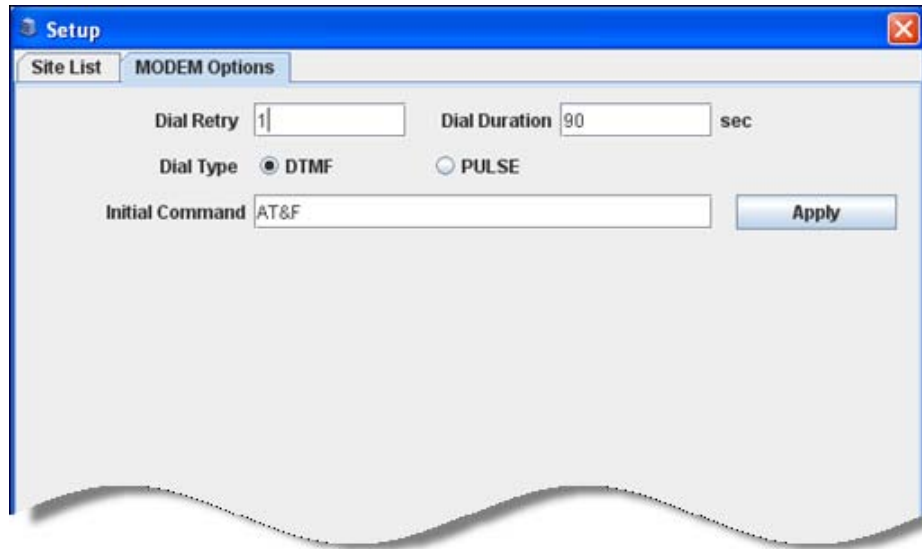

Figure 7.53 MODEM Options

- **Dial Retry** sets the number of outcall attempts to make. The default is 1, which means that if the call fails or isn't answered there will be no more attempts made.
- **Dial Duration** sets the length of time to wait for a connection to be made. The default setting is 90 seconds, which means that if a connection isn't established within 90 seconds of seizing the trunk the call will be considered a failed attempt.
- **Dial Type** sets whether the MODEM should dial using DTMF or Pulse dialing.
- **Initial Command** sets the initialization string to use to setup the MODEM call. The default is AT&F, which is compatible with 99% of MODEMs manufactured since 1990. It is recommended that you leave this setting as is unless instructed to change it by the MODEM manufacturer.

CONNECT TO AN OFFICESERV SYSTEM USING THE CLIENT APPLICATION

There are a couple of different methods you can use to connect to a system:

1. Click on **[System]** → **[Connect]**.

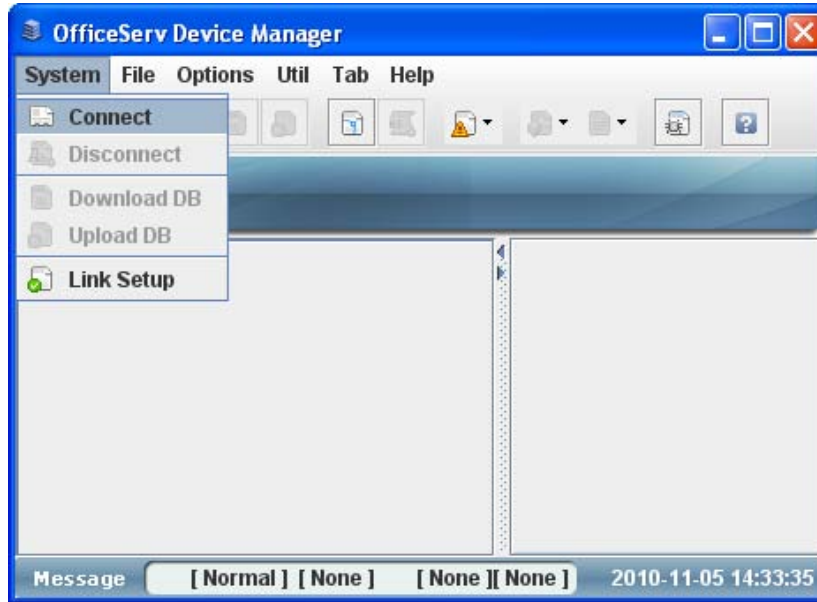

Figure 7.54 Connect to an OS System Using Client App Method 1

2. Use the Connect icon to connect to the last system you connected to. To connect to a different system, use the arrow on the right side of the connect icon to display a list of available systems.

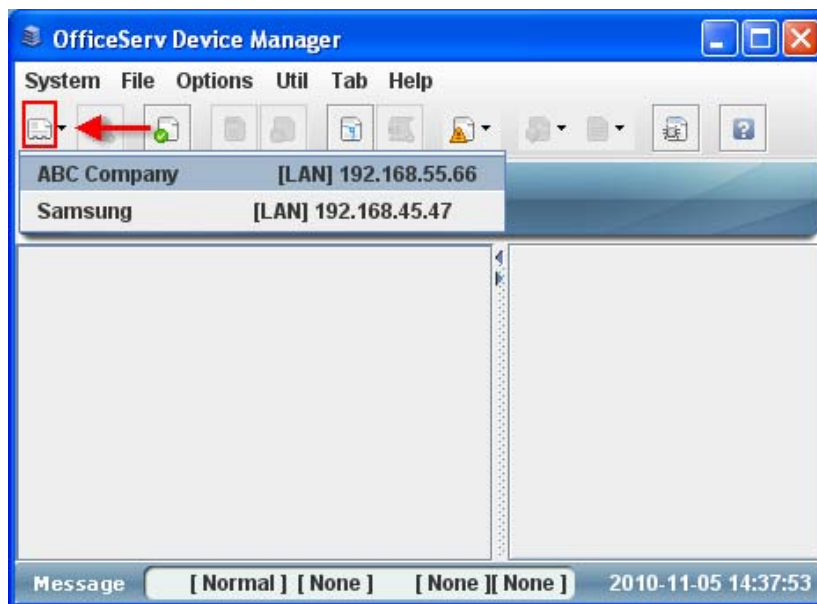

Figure 7.55 Connect to an OS System Using Client App Method 2

You'll be prompted to enter the ID and password. Default values are:

- ID = Admin
- Password = samsung

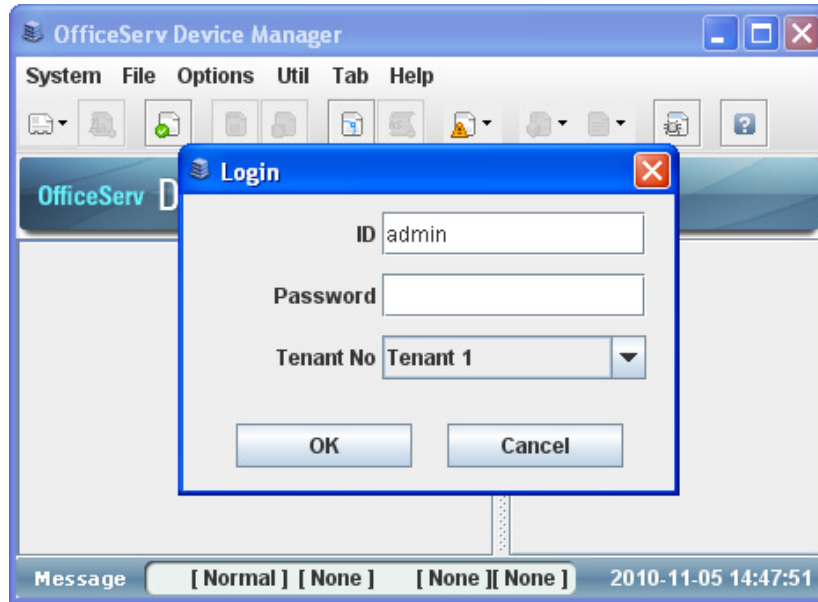

Figure 7.56 DM Login Page

Please refer to the OfficeServ Device Manager User Manual for detailed instructions on how to use Device Manager.

7.2.9 SYSTEM DATA/ACTIVITY REPORTS

The following type of reports can be output to a PC or LAN printer that is connected to the same network as the MCP/MP20: SMDR (Station Message Detail Records), UCD Reports, Traffic Reports, Alarm Reports, Hotel Report and much more. [Refer to MMC 829](#) to configure the report type and data output network configuration ([See OfficeServ 7200 Programming Manual](#)). This MMC can also configure the reports to be sent to PCs running 3rd party applications (i.e. SMDR Reporting Packages, etc.).

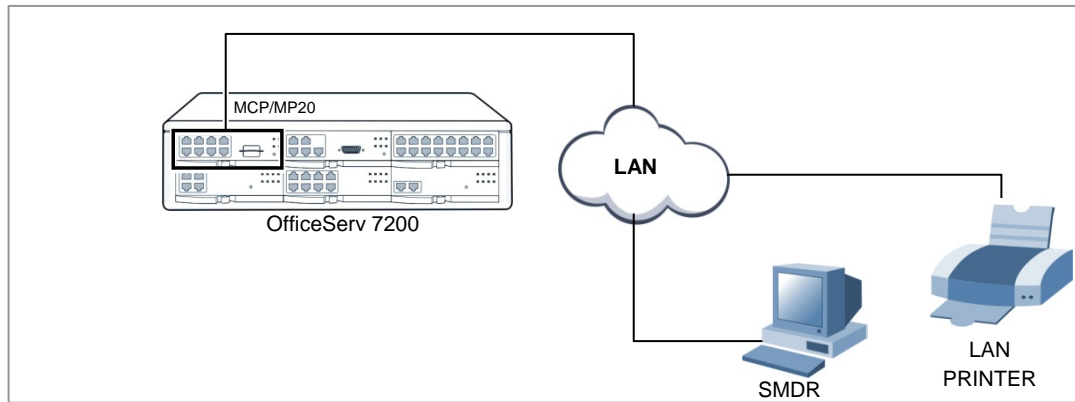

Figure 7.57 Connecting SMDR to the LAN Port of the PLIM/PLIM2

7.2.10 OS 7200 and ANALOG TERMINAL ADAPTERS (ATAs)

The OfficeServ 7200 can be SIP enabled (SIP licenses required) to interface with other 3rd party analog terminal adapters (ATA) devices, to provide voice connectivity to a VoIP network. The SIP enabled adapters can be used to support specialized voice applications such as:

- VoIP connectivity to remote analog stations.
- VoIP connectivity to remote Fax Machines.
- 911 routing to remote SIP-PSTN Gateway.

These 3rd party analog terminal adapters (ATA) are not available through Samsung, and must be purchase separately. [For more details, please refer to the special application section 2.15 of the manual.](#)

PART 8. POWER UP PROCEDURES

This section describes items to check before starting the OfficeServ 7200 system and the procedure for starting the system.

8.1 PRE-CHECK

This section describes items to check before starting the OfficeServ 7200 system.

8.1.1 Safety Precautions

- **Temperature:** Check if the temperature of the room where the system is installed is between 32°F and 113°F. If the room temperature is higher or lower than the normal operation temperature, install a heating/cooling device to maintain normal temperature.
- **Humidity:** Check if the room humidity where the system is installed is between 10 % and 90 %. Take special caution since humidity affects the electrical components and connectors of the system.
- **Direct sunlight and dust:** The room where the OfficeServ 7200 system is installed should be protected from direct sunlight and should have ventilation systems to prevent the system from malfunctioning due to dust.

8.1.2 Safety Conditions

The building where the OfficeServ 7200 system is installed should have lightning rods and grounding to protect the system against lightning and electric leakage.

- Check if the OfficeServ 7200 system is not inclined and is maintained horizontally.
- Do not place devices that may cause electromagnetic interference near the system.
- Place a fire extinguisher near the system.
- Check if the AC voltage switch of the PSU is properly set to 110 VAC power.
- Check if the grounding terminal on the rear panel of the system is properly connected to the external grounding.

8.2 STARTING THE SYSTEM

8.2.1 Starting the System with MCP

The procedure for starting the OfficeServ 7200 system is as follows:

- 1) Check if the boards and cables are properly mounted and connected to the OfficeServ 7200 cabinet.
- 2) Make sure the media card (MMC+ or SD) with the system software is in the Media Card slot.

- 3) Make sure the memory backup switch on MCP is in the OFF position for 60 seconds before putting it in the ON position.
- 4) Turn on the power of the OfficeServ 7200 expansion cabinet first, then turn on the power of the main cabinet.
- 5) Check the LEDs of the MCP and LCP boards.
- 6) The RUN LED of the MCP card lights green and the SM LED flashes when the system normally starts the booting process.
- 7) Once the booting is complete, the RUN LED of the MCP board flashes green, and the SM LED stops flashing and remains steady GREEN. At this time the system created a default database with the current hardware configuration and DIP switch settings of S3 on the MCP.
- 8) The RUN LED of the LCP board flashes green when the power supply and processor status of the expansion rack is normal.



If the Media Card is not detected

If the system cannot detect the media card, the MC/SM LED of the MCP board might not light or flash. In such cases, turn off the power of the main cabinet, replace the media card and turn the power on again. If the media card is still not detected, turn off the power of the main cabinet and eject the MCP board.

- 9) Check if the LED status of other interface boards are normal.
- 10) If the LED status of the MCP, LCP, or interface board is abnormal, turn off the power of the cabinet and turn the power on again. If this does not restore normal system operation contact Samsung Technical Support.

8.2.2 Starting the System with MP20

The procedure for starting the OfficeServ 7200 system is as follows:

- 1) Check if the boards and cables are properly mounted and connected to the OfficeServ 7200 cabinet.
- 2) Make sure the Secure Digital (SD) media card with the system software is in the Media Card slot.
- 3) Turn on the power of the OfficeServ 7200 expansion cabinet first, then turn on the power of the main cabinet.
- 4) After three minutes of RUN LED and SM LED activity, press the RESET SWITCH on the faceplate of the MP20 processor card and hold it for 10 seconds. This will create a default database with the current hardware configuration and DIP switch settings of S3 on the MP20.
- 5) The RUN LED will change from GREEN to AMBER and will stop flashing after 10 seconds. Release the RESET button and wait 3 minutes for the system to boot into service.
- 6) The RUN LED of the MP20 board lights green and the SM LED flashes when the system normally starts the booting process.

- 7) Once the booting is complete, the RUN LED of the MP20 board flashes green, and the SM LED stops flashing and remains light. At this point the system had a default database.
- 8) The RUN LED of the LCP board flashes when the power supply and processor status of the expansion rack is normal.
- 9) Check if the LED status of other interface boards are normal.
- 10) If the LED status of the MP20, LCP, or interface board is abnormal, turn off the power of the cabinet and turn the power on again. If this does not restore normal system operation contact Samsung Technical Support.

8.3 CHECKING THE FAN

When the system fan is not operating, the 48 DC power and the system operation will be turned off to prevent system overheating.

This function is set in programming to send notification within 24 hours.

The function can be set using the following methods:

- 1) Designate SYSALM key in MMC 732 and the designated key will be set on the manager's digital phone.
- 2) When the alarm is generated in the phone, the cause of alarm can be checked in MMC 851.
The MJA08 message means abnormal fan operation, therefore the system will be turned off after 24 hours.

When the alarm occurs, the fan must be replaced within 24 hours.



NOTE

REMINDER

Install blocking plates in all empty card slots of the main and expansion cabinets.

8.4 NUMBERING EXTENSIONS AND C.O. LINES

Once the OfficeServ 7200 system is booted, the MCP/MP20/LCP board verifies the boards mounted on each slot and saves this information as the default configuration of the system.

According to the setting of the S3 switch (SW6, SW7, SW8) of the MCP/MP20/LCP board, the OfficeServ 7200 system assigns 3 or 4 digits to C.O. lines, extensions, and extension groups. [Refer to Section 4. Mounting and Replacing Boards](#) of this manual for details on setting the S3 switch.

C.O. line numbers from 701 or 7001 are sequentially assigned to the C.O. line board installed on Slot 1 of the main cabinet, and following numbers are continuously assigned to the next

C.O. line board of the next slot. However, only the numbers from 701 to 799 are assigned when using 3 digits. For example, if an 8TRK/8TRK2 board is mounted on Slot 1 and an 8TRK/8TRK2 board is mounted on slot2, 701 is assigned to the C1/S1/P1 port and 712 is assigned to the C1/S2/P4 port. (Twelfth C.O. line is assigned to the fourth port of the second slot of the first cabinet.)

Extension numbers from 201 or 2001 are sequentially assigned to the extension board mounted on Slot 1 of the basic cabinet, and following numbers are continuously assigned to the next extension board of the next slot. This numbering process continues until the extension numbers are assigned to all extensions. However, only the numbers from 201 to 349 are assigned when using 3 digits.

The first port of the first 8DLI or 16DLI2 board is assigned to the attendant group as default. All C.O. lines ring this attendant extension unless the default value is changed. Thus, a phone with an LCD panel should be connected to the last port of the first 8DLI board.

500-539 or 5001-5039 is assigned to an extension group.

To view the default number plan go to MMC 724 from your keyset or use the OfficeServ Installation Tool section 2.8.0 for a graphical layout that is easier to read.

PART 9. SOFTWARE AND DATABASE MANAGEMENT

9.1 SOFTWARE MANAGEMENT on MCP and MP20

The OfficeServ 7200 operating software is stored on the media card which is inserted into the front of the MCP/MP20 card. Upon power up the OS is loaded into SRAM. The OS runs from SRAM, not from the media card. Each time the system is started the OS is copied from the media card to the OS. The MMC+ has 32 Megabytes and the Smart Media has 64 Megabytes of memory. This is formatted, with a custom format to allow faster loading, in a similar manner to a hard disk. The SD card has 1 Gigabyte of memory. In addition to the operating system these media cards can store software for the LCP card and the TEPRI/TEPRIa card. The media card also has the capability to store a backup copy of the system database.

Software can be uploaded from the media card to the TEPRI and LCP cards listed above using MMC 818 (File Control) and will be stored in those cards on-board flash memory. The cards will automatically reboot, load and run the new software when the upload process is complete. Files can be deleted using MMC 819, File Control. This is necessary to clean up the media card.

Using OfficeServ™ Manager/Installation Tool over a LAN connection to the system the software files can be uploaded to the media card. The files are first uploaded to the MCP/MP20 card and then transferred to the media card. Once the files are loaded onto the media card they can be manipulated with MMC 818 as before.

9.2 DATABASE MANAGEMENT

9.2.1 Database Management on MCP

Creating and Storing a Customer Database

Upon successful power up a default database is created based on current hardware configuration and DIP switch S3 settings on MCP card. This database is stored in SRAM on the MCP. A super capacitor protects this memory for approximately 2-3 days when power is off. The Memory backup switch S2 on MCP card must be in the ON position to protect the data based stored on SRAM.

After the technician makes necessary changes (station & group names, COS tables, routing plans etc.) to this database it is highly recommended to store a back up copy of this customer database to the media card (Smart Media, MMC+ or SD). This is accomplished by copying Customer Database from SYSDB (system database) to MCDB (media card database) using MMC 815 Customer Database program. In addition the technician can store a copy of the system database on a PC using OfficeServ Installation Tool or OfficeServ Manager depending on the software version.

Using MMC 815 the technician can set the Auto Back Up feature to automatically copy the system database to the media card on a daily or weekly time schedule. This option can also be set using OfficeServ Installation Tool or OfficeServ Manager.

When the power is off sufficient time to completely discharge the super capacitor the database stored in SRAM is lost. To restore it back in SRAM, copy MCDB (media card database) to SYSDB (system database) using MMC 815. If a copy of the customer database was stored off line on a PC using OfficeServ Installation Tool it can be uploaded into SRAM using the Utility menu in Installation Tool. When using Installation Tool to save database files name them with dates so you know what database your are restoring.

Defaulting the Database

When it is necessary to wipe out (default) the customer database, power down the main cabinet, Remove the MCP, then set The Memory backup switch S2 on MCP card to the OFF position for one full minute. Then put it back in the ON position, then put it back in slot 0 of main cabinet. Turn the system ON and let it boot up with a default database.

An alternative method is to use a MMC 811- System Restart from a keyset. Execute the " Clear Memory" option followed by the "System Restart" option.

9.2.2 Database Management on MP20

Upon successful power up a default database is created based on currently hardware configuration and DIP switch S3 settings on MP20 card. This database is stored in NAND Flash memory on the MP20. NAND flash memory does not require a battery or super capacitor to retain data. It is stored virtually forever or unless the memory chip is damaged. There is no memory backup switch on the MP20.

After the technician makes necessary changes (station & group names, COS tables, routing plans etc.) to this database it is highly recommended to store a back up copy of this customer database to the media card (MMC+ or SD). This is accomplished by copying Customer Database from SYSDB (system database) to MCDB (media card database) using MMC 815 Customer Database program. In addition the technician can store a copy of the system database on a PC using OfficeServ Installation Tool.

Using MMC 815 the technician can set the Auto Back Up feature to automatically copy the system database to the media card on a daily or weekly time schedule. This option can also be set using OfficeServ Installation Tool.

For whatever reason the backup copy of the database on the media card can replace the database stored in NAND Flash. Using MMC 815 to copy MCDB (media card database) to SYSDB (system database). If a copy of the customer database was stored off line on a PC using OfficeServ Installation Tool it can be uploaded into SRAM using the Utility menu in Installation Tool. Database changes are copied from SRAM to NAND Flash every 5 minutes or

immediately after setting programming to “Disabled” then exiting. When using Installation Tool to save database files name them with dates so you know what database your are restoring.

Defaulting the Database

When it is necessary to wipe out (default) the customer database on the MP20, press and hold the RESET button for 10 seconds until the RUN LED lights steady amber, then release the reset button. The system will reboot and come up with a default database based on current hardware configuration and DIP switch S3 settings on MP20 card.

An alternative method is to use a MMC 811- System Restart from a keyset. Execute the “ Clear Memory” option followed by the “System Restart” option.

PART 10. ADDING CARDS TO THE SYSTEM

10.1 ADDING STATIONS AND TRUNKS

- 1) Power the OfficeServ 7200 OFF before adding a new board. Locate a compatible empty card slot. Pull the ejector handle forward, then insert the new card into the slot and push firmly in the middle of the card ejector to ensure that it is fully inserted into the back plane connector.
- 2) Restore power to the system.
- 3) After the new cards are inserted, the system must be told to recognize the new cards. This is done through the use of MMC 806 Card Pre-Install. Use this MMC for each new card that is installed.
- 4) The new cards must be assigned directory numbers according to the system numbering plan in MMC 724. The technician must know the software port assignments of the new cards so the ports can be assigned correct numbers.